

**Model # HLS21UOTREC**

# 21 Gallon/80 Liter

## **RECTANGULAR OPEN TOP RECYCLE BIN with AbsorbX® Odor Control**

Make it easy to sort recyclables quickly and cleanly in high-traffic venues like cafeterias, lobbies, kitchens, stores, and more. Paired with a 21 Gallon Stainless Steel Rectangular Open Top bin, the lid features a push button release for easy access. The universally recognizable, color-coding and decal clearly mark the bin for recycling, while the dual AbsorbX® Odor Filters neutralize odors.

Purchase separately or with the Compost and Trash bins for a complete waste disposal solution.



### **FEATURES**

- ✓ **ATTRACTIVE RECYCLE BIN FOR HIGH-TRAFFIC AREAS**
- ✓ **LARGE CAPACITY ACCOMMODATES BUSY COLLECTIONS SITES**
- ✓ **MAY BE UTILIZED WITH TRASH BIN AND COMPOST BIN FOR FULL WASTE COLLECTION SOLUTION**
- ✓ **ARRANGE HORIZONTALLY OR VERTICALLY AS NEEDED**
- ✓ **STAINLESS STEEL FINISH IS SMUDGE-RESISTANT AND EASY TO CLEAN**
- ✓ **DUAL REPLACEABLE ODOR FILTERS NEUTRALIZE ODORS**



For product details and pricing:



1-650-535-4378



[hlscommercial.com](http://hlscommercial.com)

# SPECIFICATIONS

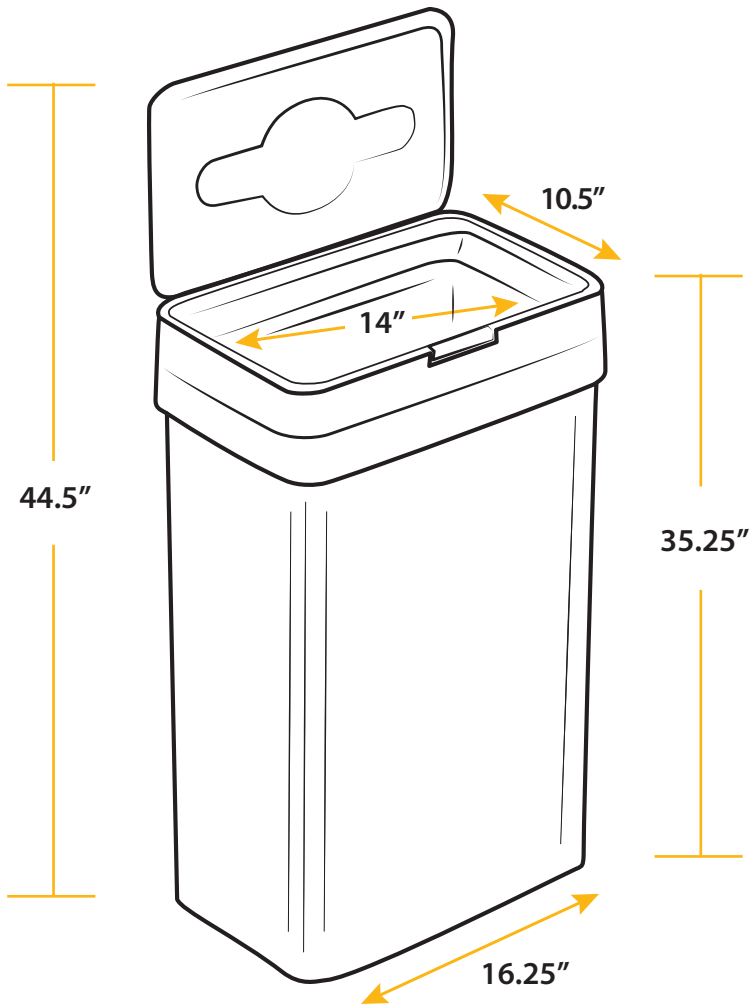

AbsorbX® Replaceable  
Odor Filters (2/can)

**Model:** HLS21UOTREC

**Dimensions:** 16.25" L x 10.5" W x 35.25" H

**Package Dimensions:** 17.9" L x 12" W x 34.8" H

**Product Weight:** 10.6 lbs.

**Package Weight:** 15 lbs.

**Capacity:** 21 Gallons (80 Liters)

**Material:** Stainless Steel