

## PA-100 Solar Actuator Data Sheet

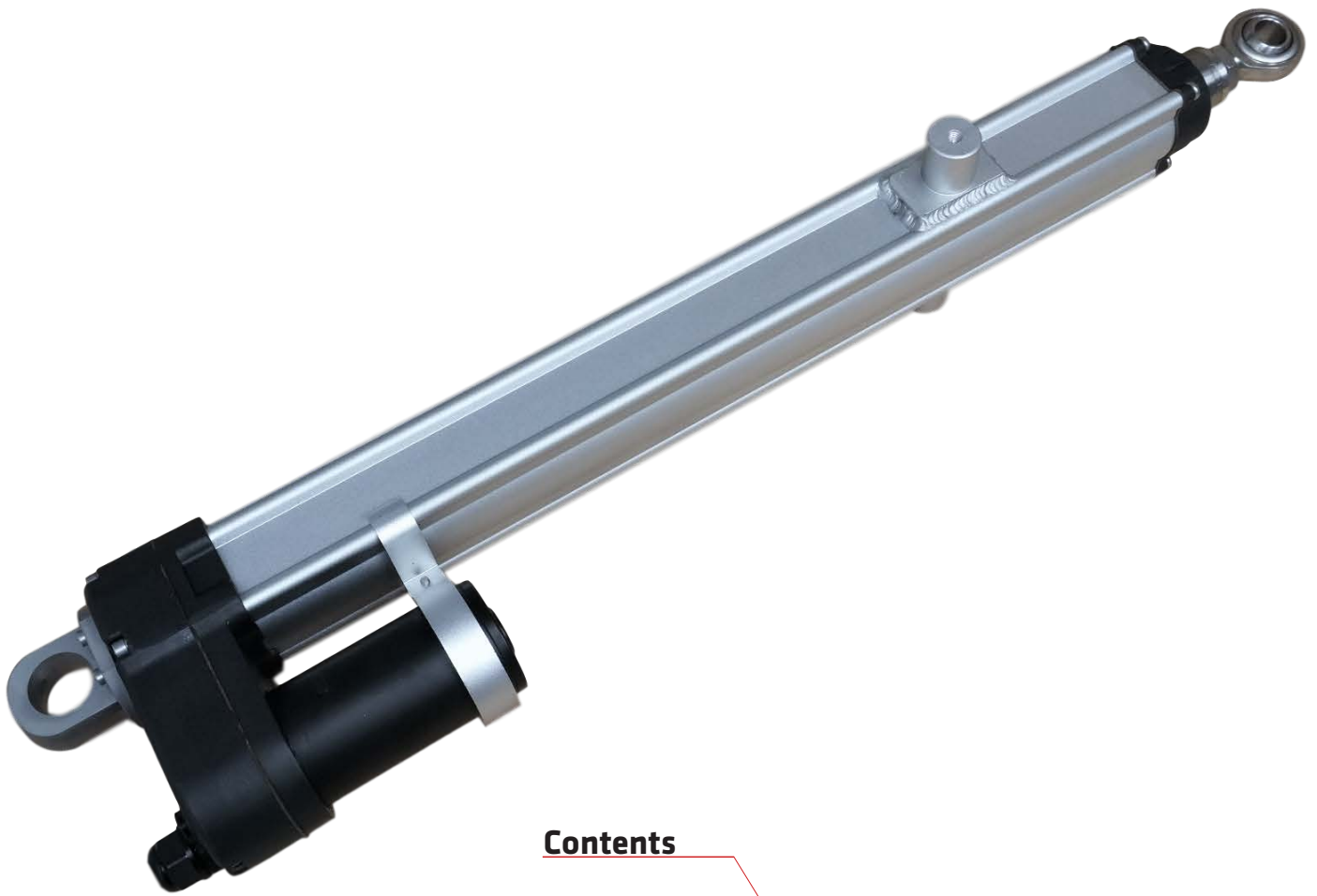

### Contents

Specifications	Page 2
Dimensions	Page 3
Load vs Speed/Current	Page 4
Feedback Options	Page 5

# Specifications



Load (LBS)		No Load Current (A)			Full Load Current (A)			Speed (inch/sec)	
Dynamic	Static	12VDC	24VDC	36VDC	12VDC	24VDC	36VDC	No Load	Full Load
3,300	10,000	<1.0	<1.0	<1.0	12.0A	6.0A	4.1A	0.08	0.06

<b>Stroke</b>	Can customize from 4" to 45"
<b>Protection Class</b>	IP66M
<b>Operational Temperature</b>	-30°C to 70°C (-22°F to 158°F)
<b>Noise</b>	56 dB
<b>Duty Cycle</b>	12%
<b>Limit Switch</b>	Internal, non-adjustable
<b>Limit Switch Feedback</b>	Yes
<b>Feedback Options</b>	Hall Effect (see Page 5)
<b>Wire Length</b>	82"
<b>Motor Type</b>	Brushed DC Motor
<b>Screw Type</b>	ACME Screw (Integrated Brake)
<b>Housing Material</b>	Aluminum Alloy
<b>Gear Material</b>	Powder Metallurgy
<b>Rod Material</b>	Stainless Steel
<b>Certifications</b>	UV Ray, Salt Exposure, UL



# Dimensions

(Dimensions in inches)

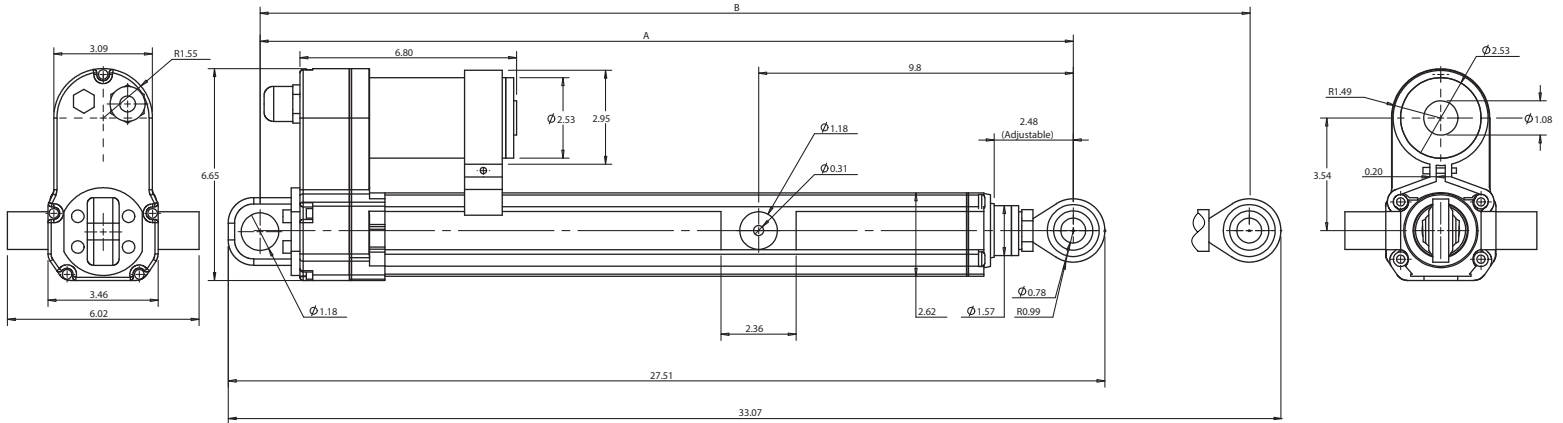
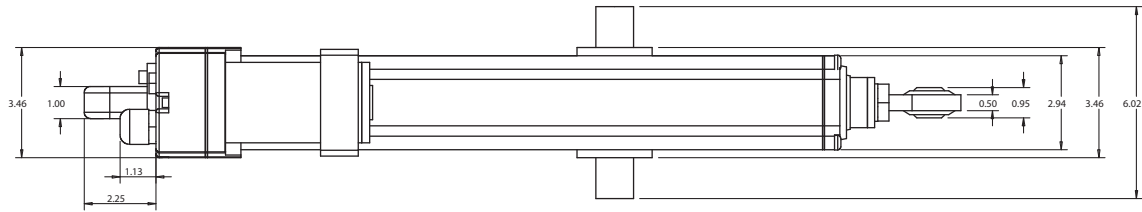

## Hole to Hole

PA-100	Stroke	4	6	8	10	12	14	16	18	20	22	24	30	36	40	45
	A	17.37	19.37	21.37	23.37	25.37	27.37	29.37	31.37	33.37	35.37	37.37	46.37	52.37	56.37	61.37
B	21.37	25.37	29.37	33.37	37.37	41.37	45.37	49.37	53.37	57.37	61.37	76.37	88.37	96.37	106.37	

### For Stroke Length 4" to 24"

A = Stroke Length + 13.37"

B = Stroke Length x2 + 13.37"

### For Stroke Length 26" to 45"

A = Stroke Length + 16.37"

B = Stroke Length x2 + 16.37"



# Load vs Speed

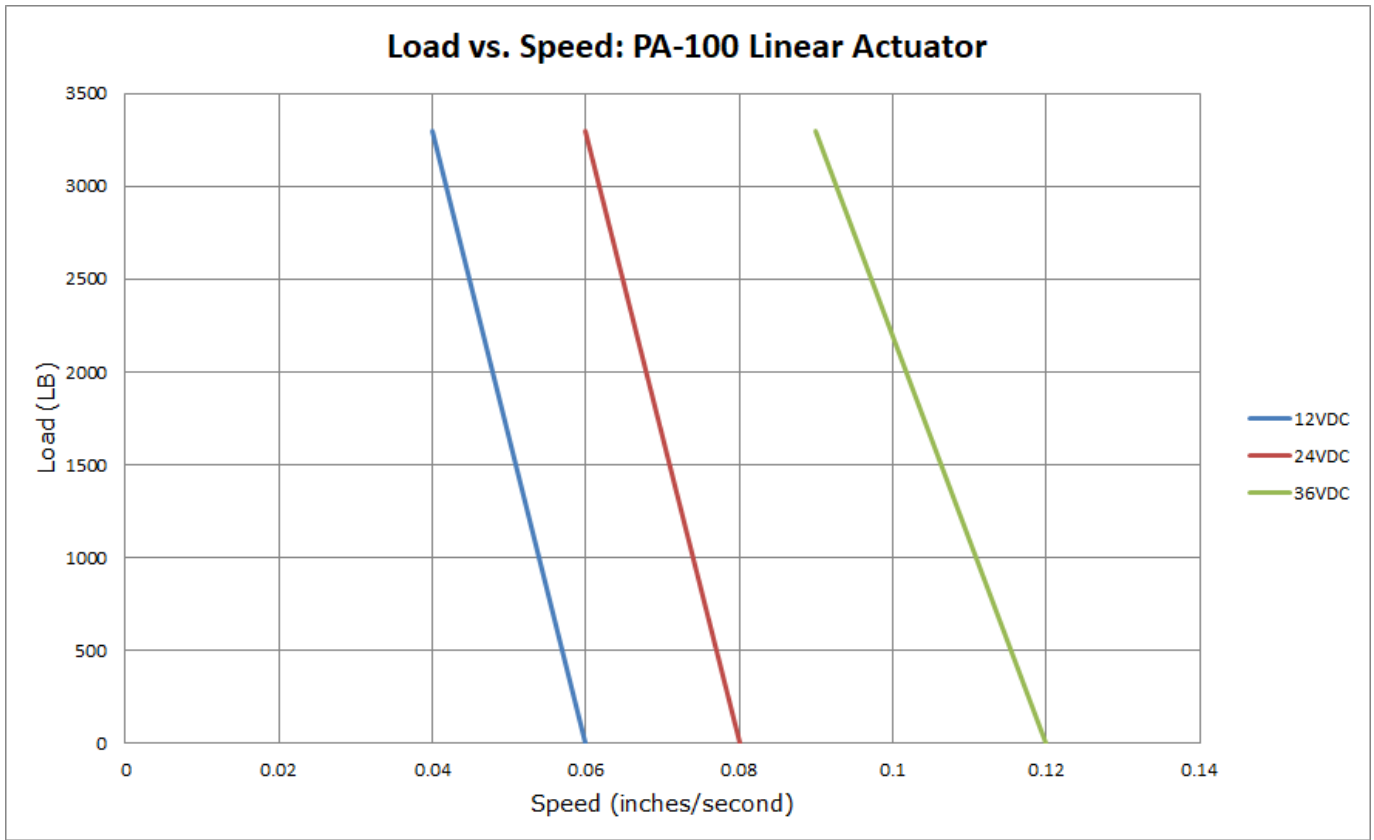

# Load vs Current

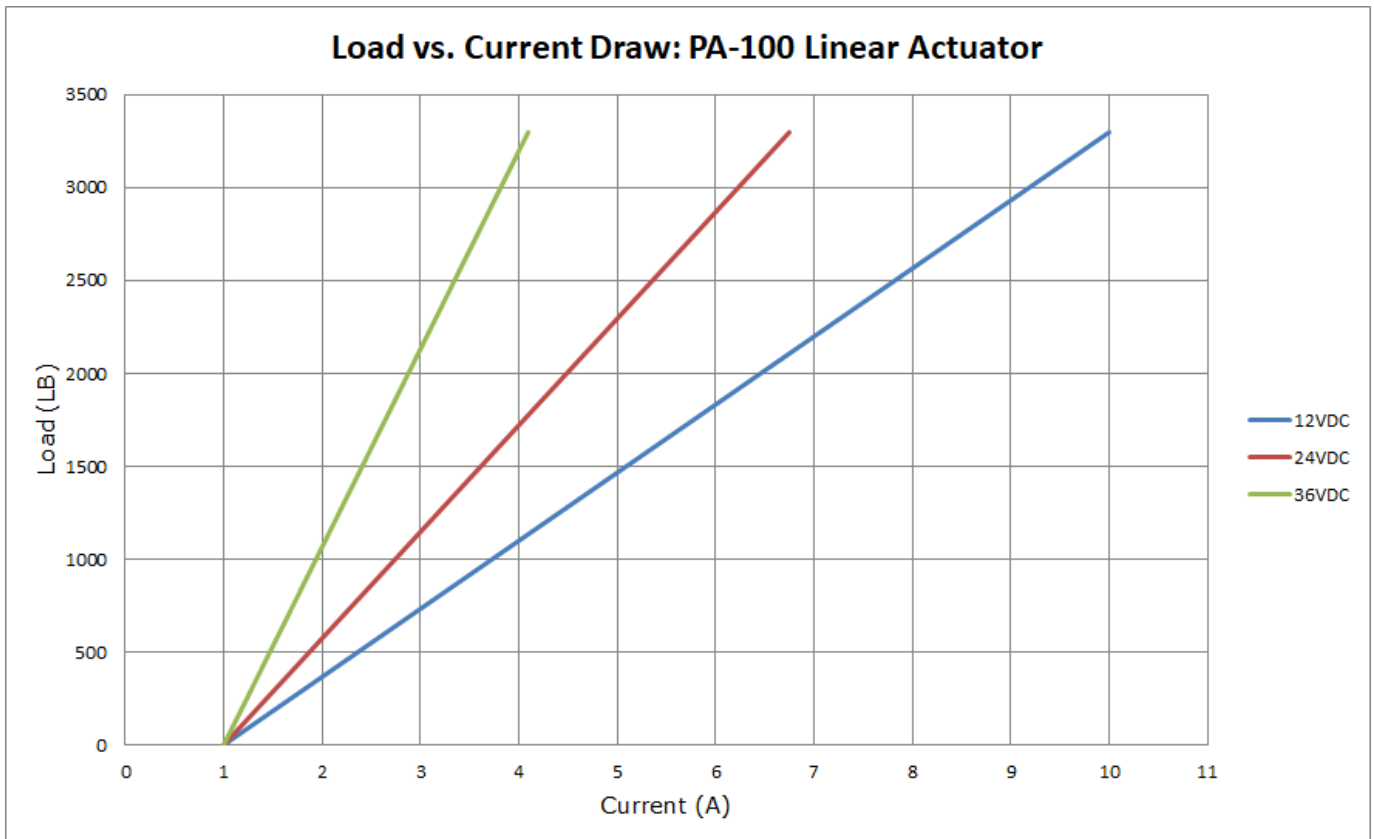

# Hall Effect Specifications



Pulses/inch	Resolution
2263	0.00177

## 6-Pin Hall Effect Connector

Front View

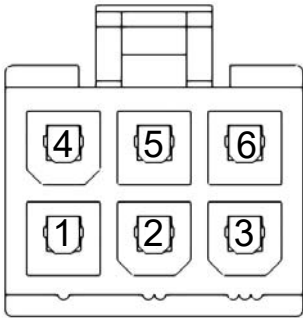

Motor		Hall Sensor			
4	5	2	3	1	6
M+ (Extend)	M- (Retract)	GND	+5VDC	Signal 2 Leads when Extending	Signal 1 Leads when Retracting

