

PA-09

Data Sheet



Contents

Specifications	2
Dimensions	3
Speed/Current vs Load	4
Connectors & Feedback	5
Internal Components	6
Internal Descriptions	7

Specifications



Load (LBS)		No Load Current (A)				Full Load Current (A)				Speed (inch/sec)	
Dynamic	Static	12VDC	24VDC	36VDC	48VDC	12VDC	24VDC	36VDC	48VDC	No Load	Full Load
225	225	1.5	0.6	0.5	0.3	4.0	3.0	2.0	1.5	0.59	0.43
330	330	1.5	0.6	0.4	0.3	4.0	3.0	2.0	1.5	0.39	0.27
450	450	1.2	0.5	0.4	0.3	4.0	3.5	2.5	1.5	0.24	0.20

Input Voltage	12VDC
Stroke	1" to 40"
Feedback	Hall Effect, Limit Switch Feedback, and Potentiometer (See Page 5)
Duty Cycle	25% (5 minutes on, 15 minutes off)
Weather Protection	IP66
Overload Protection	NA
Operational Temperature	-25°C to 65°C (-13°F to 149°F)
Operating Noise	<45 dBA
Limit Switch	Built-In (Non-Adjustable)
Cable Length	40"
Connector	Molex Mini-Fit Jr 2-Pin
Front Mounting Hole Size	0.32"
Rear Mounting Hole Size	0.32"
Actuator Type	Mini, Industrial
Motor Type	Brushed DC Motor
Screw Type	ACME
Stroke Rod Material	Stainless Steel
Housing Material	Aluminum Alloy 6062
Gear Material	Polyformaldehyde
Compatible Mounting Brackets	BRK-09, BRK-10
Warranty	18 Months



Dimensions

(Dimensions in inches)

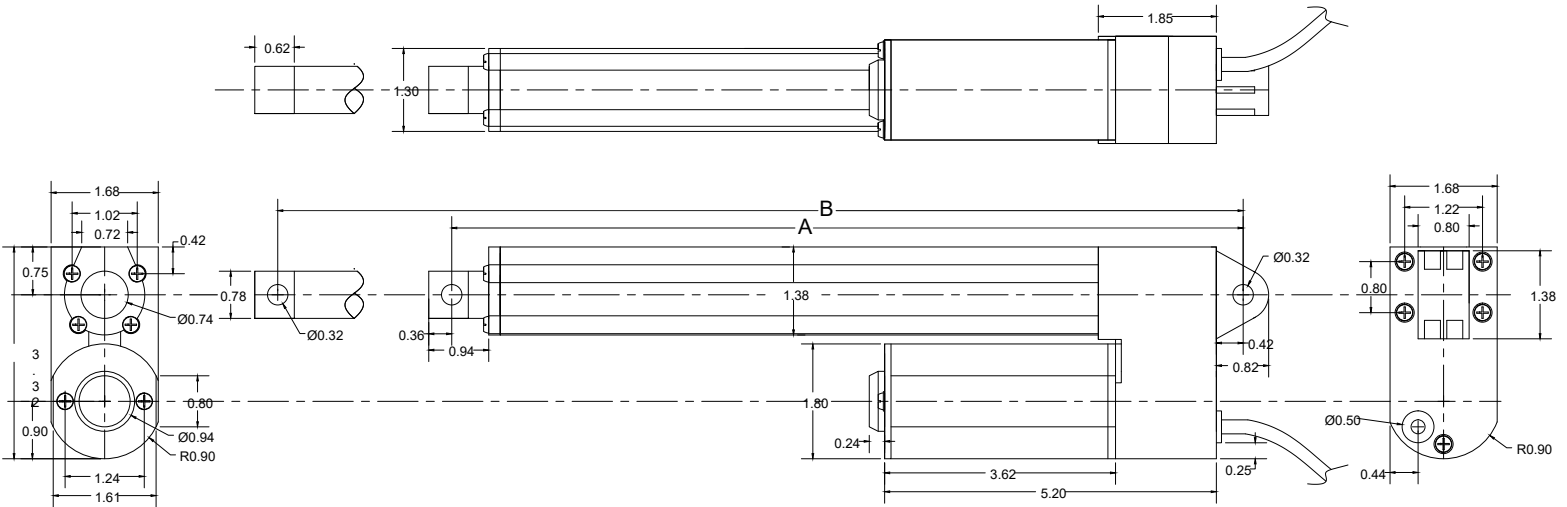

Hole to Hole

PA-09	Stroke	1	2	3	4	6	8	9	10	12	14	16	18	20	22	24	30	40
	A	5.53	6.53	7.53	8.53	10.53	12.53	13.53	14.53	17.71	19.71	21.71	23.71	25.71	27.71	30.50	36.50	47.87
B	6.53	8.53	10.53	12.53	16.53	20.53	22.53	24.53	29.71	33.71	37.71	41.71	45.71	49.71	54.50	66.50	88.87	

For Stroke Length less than 12"

A = Stroke Length + 4.53"

B = Stroke Length x 2 + 4.53"

For Stroke Length of 12" to less than 24"

A = Stroke Length + 5.71"

B = Stroke Length x 2 + 5.71"

For Stroke Length 24" to 30"

A = Stroke Length + 6.50"

B = Stroke Length x 2 + 6.50"

For Stroke Length greater than 30"

A = Stroke Length + 7.87"

B = Stroke Length x 2 + 7.87"

For Potentiometer Units - Stroke Length up to 8"

A = Stroke Length + 5.50"

B = Stroke Length x 2 + 5.50"



Speed vs Load

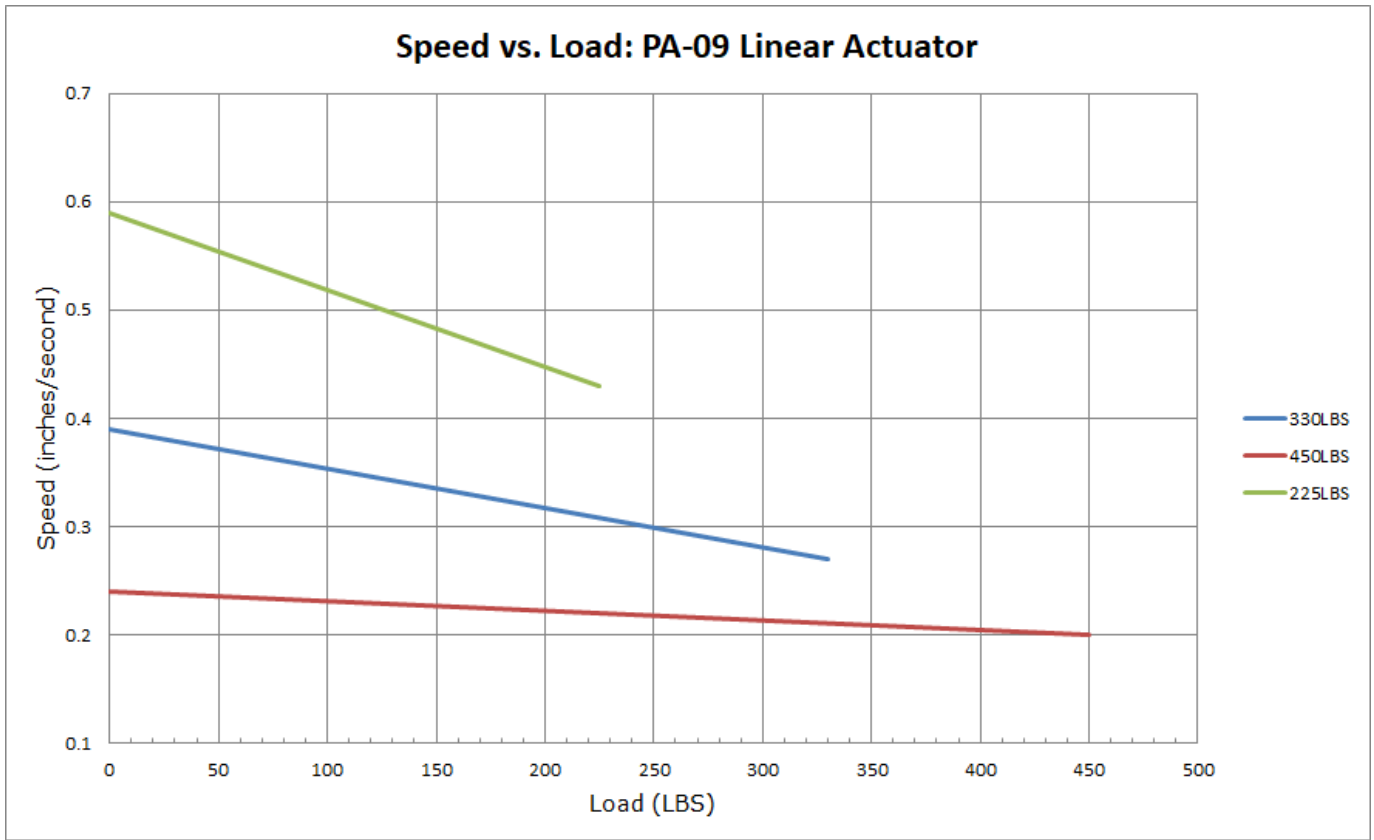

Current vs Load

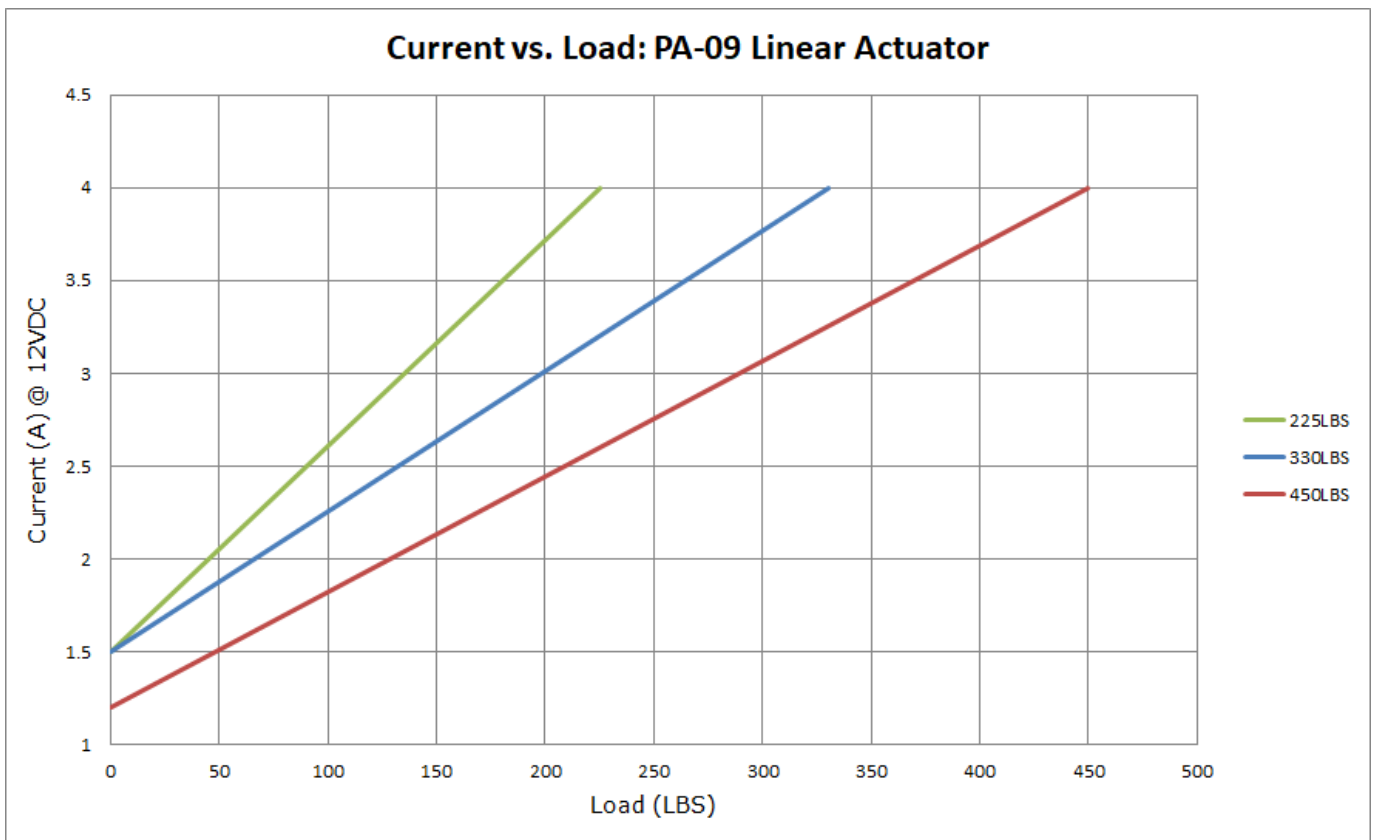



Connectors & Feedback

2-Pin Connector (Standard)

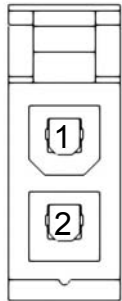

Motor	
1	2
M+	M-

Component	Part Name	Part Number	Mating Part Number
Housing	Molex Mini Fit Jr 2-Pin Receptacle	39-01-2025	39-01-2029 /39-01-2026

6-Pin Hall Effect Connector

*For Stroke Length up to 40"

Front View

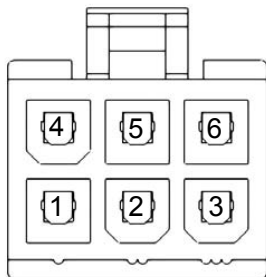

Motor		Hall Sensor			
4	5	2	3	1	6
M+ (Extend)	M- (Retract)	GND	+5VDC	Signal 2 Leads when Extending	Signal 1 Leads when Retracting

Component	Part Name	Part Number	Mating Part Number
Housing	Molex Mini Fit Jr 6-Pin Receptacle	39-01-2065	39-01-2069/ 39-01-2066

Output Signal Extending		Output Signal Retracting	
Hall Effect 1 Signal		Hall Effect 1 Signal	
Hall Effect 2 Signal		Hall Effect 2 Signal	

Force	Resolution (pulses/inch)
250	160
330	650
450	433

Potentiometer Specifications

*For Stroke Length up to 8"

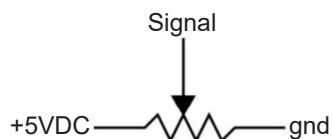

Resistance*	Number of Turns	Tolerance
0-10kΩ	10	+/- 5%

*Actual resistance value may vary within the 0-10kΩ range based on stroke length

Internal Components

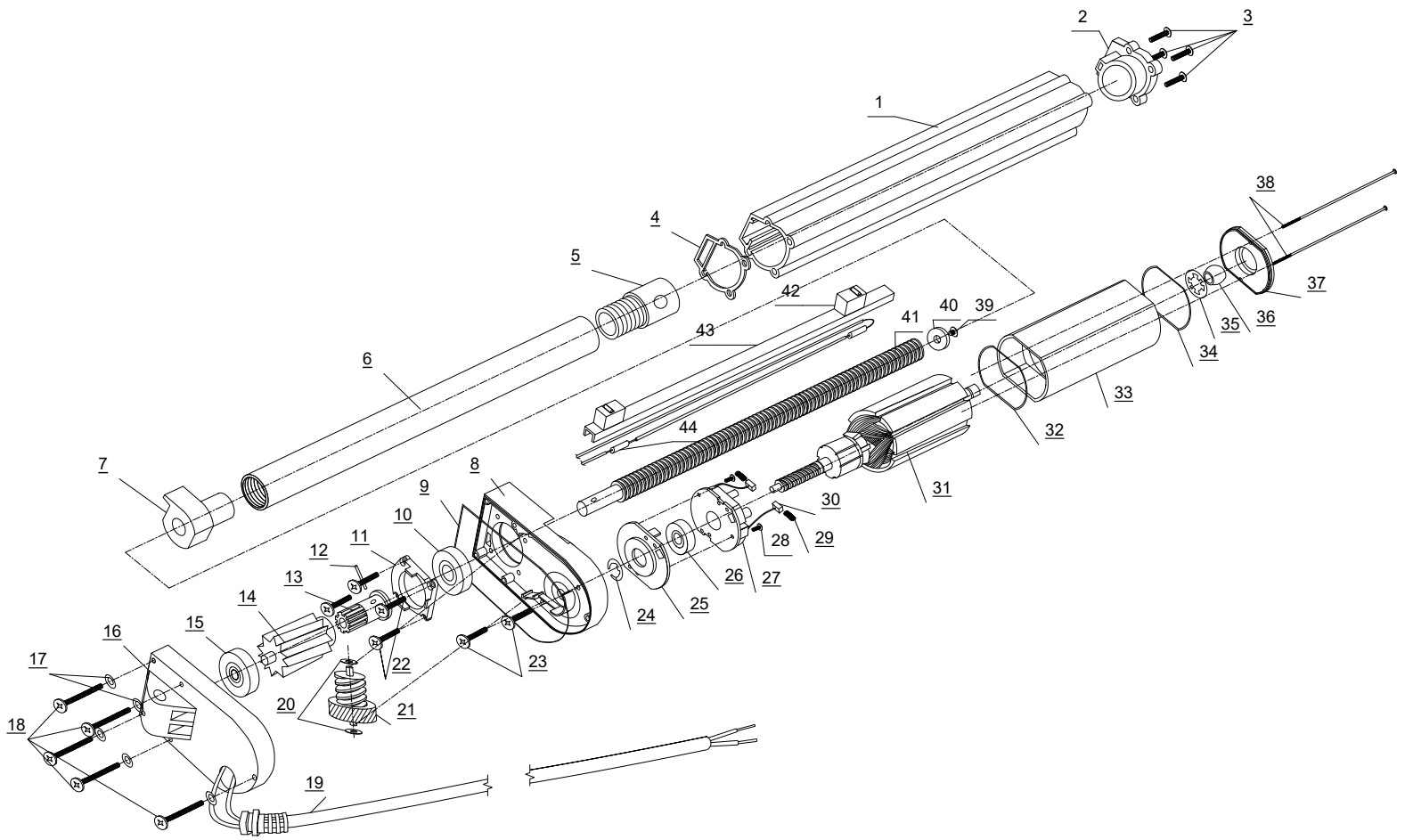

Internal Descriptions



Item	Description	Qty
1	Shaft Encloser	1
2	Shaft Enclosure Top Cap	1
3	Top Cap Screw	4
4	Shaft Encloser Bottom Gasket	1
5	Shaft Top with Mounting Hole	1
6	Shaft	1
7	Shaft Base with Limit Switches Arm	1
8	Actuator Base	1
9	Actuator Base Gasket	1
10	Shaft Bearing	1
11	Shaft Bearing Holder	1
12	Shaft Gear Cap Pin	1
13	Shaft Gear Cap	1
14	Shaft Gear	1
15	Bottom Shaft Bearing	1
16	Base Cover with Mounting Hole	1
17	Base Cover Screw Gasket	5
18	Base Cover Screw	5
19	Power Cable	1
20	Gear Washer	2
21	Gear	1
22	Shaft Bearing Holder Screw	4

Item	Description	Qty
23	Motor Base Screw	2
24	Electric Motor Snap Ring	1
25	Electric Motor Base	1
26	Electric Motor Bearing	1
27	Brush Holder PCB	1
28	Brush Holder Screw	2
29	Electric Motor Brush Spring	2
30	Electric Motor Brush	2
31	Electric Motor Rotor	1
32	Motor Enclosure Bottom Gasket	1
33	Electric Motor Encloser with Stator	1
34	Motor Enclosure Top Gasket	1
35	Electric Motor Top Bearing Holder	1
36	Electric Motor Top Bearing	1
37	Electric Motor Top Cap	1
38	Motor Enclosure Screw	2
39	Shaft Drive End Support Screw	1
40	Shaft Drive End Support	1
41	Treaded Shaft Drive / Lead Screw	1
42	Limit Switch	2
43	Limit Switches Base	1
44	Diode	2