



Equipment Supply Company



Instruction Manual

2 Ton Air Bladder Jack

ESCO #92040 (2-Stage)

ESCO #92041 (3-Stage)

PRO
SERIES



WARNING:

THIS PRODUCT, AS WELL AS ALL TIRE TOOLS, SHOULD NEVER BE USED BY PERSONS UNLESS THEY HAVE BEEN TRAINED PROPERLY ACCORDING TO OSHA REGULATIONS 29CFR 1910.177 ENTITLED "SERVICING SINGLE-PIECE & MULTIPIECE RIM WHEELS".

FOR THE SAFE USE OF THIS PRODUCT, PLEASE READ INSTRUCTIONS. FAILURE TO DO SO CAN LEAD TO A VOID IN WARRANTY OR SERIOUS INJURY. PLEASE USE THIS TOOL AND OTHER TIRE SERVICE TOOLS WITH THE UPMOST SAFETY PRECAUTIONS.

CAUTION

Before using the product, carefully read the instructions manual and all stickers and warnings noted on the product. This is necessary to avoid injury to the operator and damage to the product.

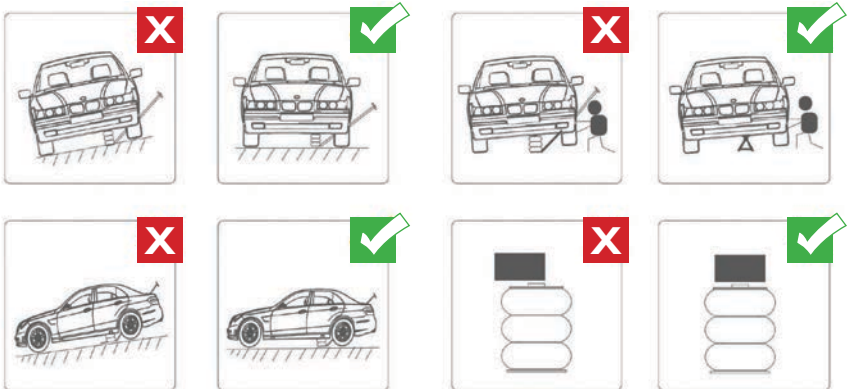

Product Description

The Model #92040 & 92041 are professional 2 Ton Air Bladder Jacks. The ESCO Bladder Jacks are ideal for tire technicians and bodywork shops. Recommended for Automotive and small SUV/Trucks (consult vehicle user manual for vehicle weight and specifications for lifting).

Product Specifications:

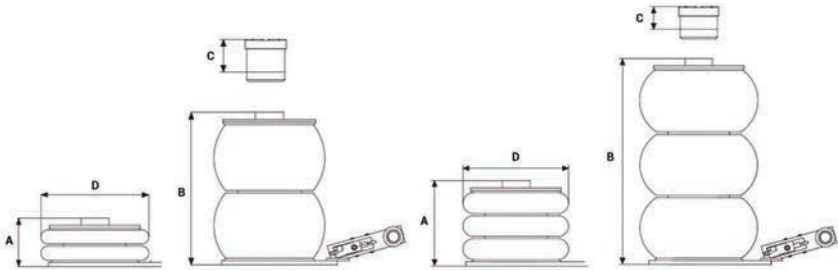

Model # Description	92040 2-Stage	92041 3-Stage
Capacity	2 Ton (4,000 lbs.)	2 Ton (4,000 lbs.)
Working Air Pressure	100-145 PSI	100-145 PSI
A (Min. Height)	4.5 in. (115mm)	7.9 in. (200mm)
A+B+C (Max. Height)	17 in. (430mm)	22 in. (560mm)
B (Lifting Height)	9.25 in. (235mm)	11.8 in. (300mm)
C (Extension Height)	3 in. (80mm)	2.25 in. (60mm)
D (Width)	10.4 in. (265mm)	9.8 in. (250mm)

MAINTENANCE

1. Clean the outside of the jack with a dry, clean, soft cloth and periodically lubricate the air valve with a light oil in normal service.
2. When not in use, store jack in a dry location with the bags fully lowered.
3. Before each use, check all parts. If any part of the jack is damaged or suspect, remove the jack from service and contact ESCO for any repairs.

SAFETY INFORMATION AND DISCLAIMER

To avoid personal injury or property damage while using this product, read and follow all DANGERS, WARNINGS, CAUTIONS, and INSTRUCTIONS that are attached to, or included with, this product.

1. This product is designed and made only for lifting vehicles.
2. Never lift loads on sloping, uneven or soft ground.
3. The maximum load is 2 Ton. **DO NOT** exceed the rated capacity.
4. Air pressure must **NOT** exceed 145 psi (1 Mpa).
5. Keep jack clean for safe and best performance.
6. **DO NOT** adjust the safety valve.
8. **DO NOT** make any modifications to the jack.
9. **DO NOT** use the jack if damaged or have malfunction parts.
10. Be sure **NOT** to wear loose clothing or jewelry when operating jack.
10. Wear ANSI approved safety goggles when operating jack.
11. Only use the jack on a surface that is stable, level, dry and not slippery, and capable of sustaining the load.
12. Before starting lifting, it is necessary to block the vehicle by placing two wedges by the wheels, as shown on the label.
13. Make sure the vehicle lifting point suggested by the car manufacturer is stable and properly centered on the saddle.
14. After lifting the load it is absolutely essential to rest it on jack stands of adequate capacity. **DO NOT** work under load that is supported only by a jack.
15. ESCO cannot be held responsible for damage or injury resulting from unsafe use of the product; lack of maintenance; or incorrect product and system application.
16. Contact ESCO when in doubt about safety precautions or applications.

INSTRUCTIONS

Step 1: Connect Air Supply

Connect the air supply line to the air valve.

Step 2: Check For Leaks

Attach shop air line and check for leaks before use.

Step 3: Apply Emergency Brake and Wheel Wedges

Before lifting, apply the emergency brake and use wheel wedges to block all wheels to prevent any movement of the vehicle.

Step 4: Place Jack

Position the jack near desired lifting point.

Step 5: Raising The Jack

Press the "UP" button to raise the load to desired height. USE JACK STANDS with adequate capacity to support the load.

Step 6: Lowering The Jack

Raise load enough to carefully remove jack stands. Then SLOWLY and CAREFULLY lower the load by pressing the "DOWN" button.

RECOMMENDED PRODUCTS



#10497



#10498



#10498K

#92040 Parts Breakdown

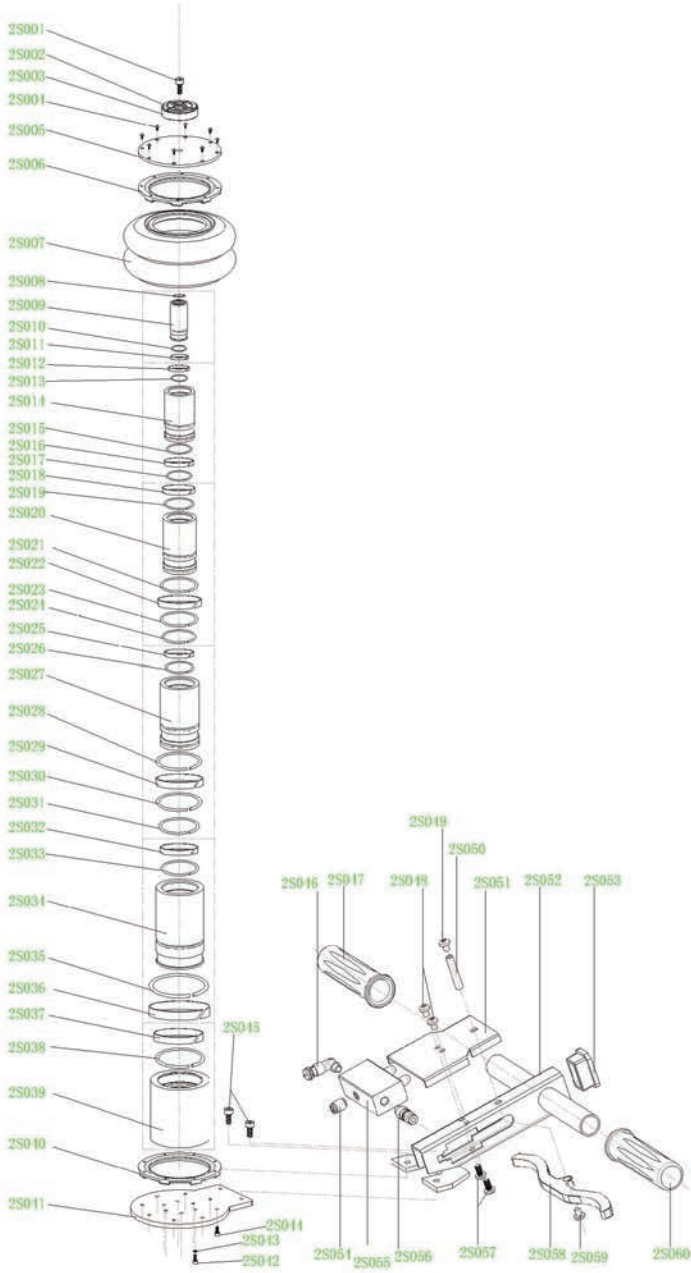

#92040 Replacement Part Numbers

Part No.	Description	Part No.	Description
2S001	<i>screw</i>	2S031	<i>locking ring</i>
2S002	<i>rubber plate</i>	2S032	<i>guider ring</i>
2S003	<i>top cover</i>	2S033	<i>locking ring</i>
2S004	<i>screw</i>	2S034	<i>inner sleeve</i>
2S005	<i>panel</i>	2S035	<i>locking ring</i>
2S006	<i>flange</i>	2S036	<i>guider ring</i>
2S007	<i>balloon</i>	2S037	<i>guider ring</i>
2S008	<i>o ring</i>	2S038	<i>locking ring</i>
2S009	<i>piston</i>	2S039	<i>outer sleeve</i>
2S010	<i>locking ring</i>	2S040	<i>flange</i>
2S011	<i>guider ring</i>	2S041	<i>base</i>
2S012	<i>guider ring</i>	2S042	<i>screw</i>
2S013	<i>locking ring</i>	2S043	<i>spacer</i>
2S014	<i>inner sleeve</i>	2S044	<i>screw</i>
2S015	<i>locking ring</i>	2S045	<i>screw</i>
2S016	<i>guider ring</i>	2S046	<i>safe valve</i>
2S017	<i>locking ring</i>	2S047	<i>grip cover</i>
2S018	<i>guider ring</i>	2S048	<i>screw</i>
2S019	<i>locking ring</i>	2S049	<i>screw</i>
2S020	<i>inner sleeve</i>	2S050	<i>screw nut</i>
2S021	<i>locking ring</i>	2S051	<i>switch cover</i>
2S022	<i>guider ring</i>	2S052	<i>handle</i>
2S023	<i>locking ring</i>	2S053	<i>plug</i>
2S024	<i>locking ring</i>	2S054	<i>fitting</i>
2S025	<i>guider ring</i>	2S055	<i>switch</i>
2S026	<i>locking ring</i>	2S056	<i>fitting</i>
2S027	<i>inner sleeve</i>	2S057	<i>screw</i>
2S028	<i>locking ring</i>	2S058	<i>switch grip</i>
2S029	<i>guider ring</i>	2S059	<i>screw</i>
2S030	<i>locking ring</i>	2S060	<i>grip cover</i>
2T80	<i>3" extension</i>		

#92041 Parts Breakdown

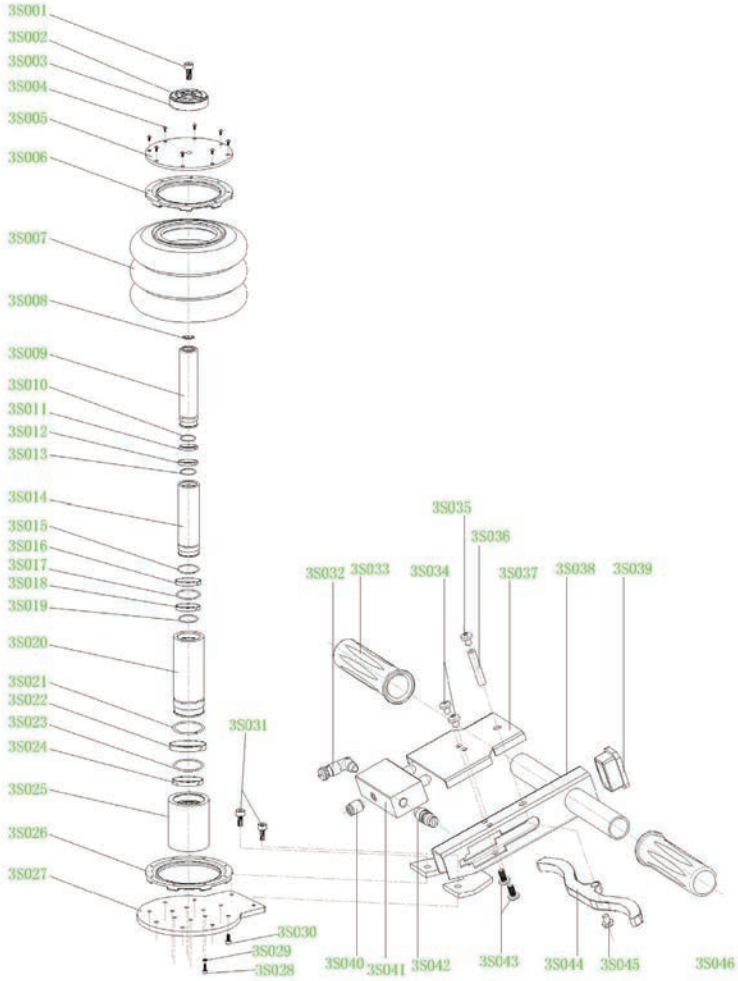

#92041 Replacement Part Numbers

Part No.	Description	Part No.	Description
3S001	screw	3S024	guider ring
3S002	rubber plate	3S025	outer sleeve
3S003	top cover	3S026	flange
3S004	screw	3S027	base
3S005	panel	3S028	screw
3S006	flange	3S029	spacer
3S007	balloon	3S030	screw
3S008	o ring	3S031	screw
3S009	piston	3S032	safe valve
3S010	locking ring	3S033	grip cover
3S011	guider ring	3S034	screw
3S012	guider ring	3S035	screw
3S013	locking ring	3S036	screw nut
3S014	inner sleeve	3S037	switch cover
3S015	locking ring	3S038	handle
3S016	guider ring	3S039	plug
3S017	locking ring	3S040	fitting
3S018	guider ring	3S041	switch
3S019	locking ring	3S042	fitting
3S020	inner sleeve	3S043	screw
3S021	locking ring	3S044	switch grip
3S022	guider ring	3S045	screw
3S023	locking ring	3S046	grip cover
2T60	2.25" extension		



“Providing Quality Hydraulic Repair and Technical Support for All Your Hydraulic Product Needs”

GUARANTEED 1 Day Turnaround Service.

Received by ESCO - Repaired in 24 Hours - Returned to You!

- ▶ ESCO will pick up product for repair/warranty at your location.
- ▶ ESCO will guarantee Repair/Service for 30 days.
- ▶ ESCO has rental tools available
- ▶ ESCO repairs IMT, FEC, Stellar, Blackhawk, OTC, Power Team, Ame Int., & Enerpac hydraulic pumps, bead breaker, and cylinders.
- ▶ Authorized ESCO Repair & Warranty Centers Located through the US & Canada. For more information contact your ESCO sales representative.
- ▶ Technical Support Over the Phone Available by Calling 1-800-352-9852

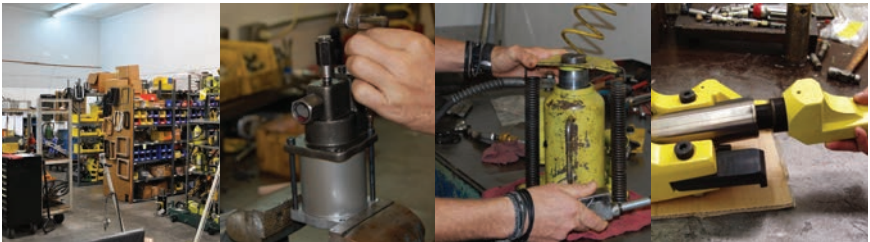

Prompt, reliable service after the sale is very important to ESCO. ESCO maintains an in-house repair facility in Brooksville, Florida. To insure that our customers have as little down-time as possible, we offer a 1 day turnaround service. Our factory repair service is equipped with all the tools and machinery needed to repair your equipment quickly and affordably. Our trained technicians are the best in the industry. Not only do we service our own products, but we also service our competitors' products.

In addition to ESCO's 30 years of providing quality repair service, ESCO has reached out and partnered with more than 50+ hydraulic repair facilities across the US & Canada, to deliver quality repair and timely return of products. Visit www.esco.net or call 1.800.352.9852 to hear more about the newly added "Authorized ESCO Warranty & Repair Facilities" across the US.

If you have a bead breaker, ram, or hydraulic pump that needs repair, ESCO fixes your product with factory parts and guarantees the repair. In addition to servicing ESCO brand products, we also repair CP, IMT, Elrick, Branick, Goodyear, FEC, Ame Int., and Haltec lines of hydraulic bead breakers, rams, pumps, jacks, and many other hydraulic tire service equipment.

The Proper Tools To Keep Your Equipment **MOVING**



Scan this Code to Go to
the ESCO website

WWW.ESCO.NET



CONTACT INFO:

www.esco.net - info@esco.net

15270 Flight Path Drive

Brooksville, FL 34604

PH. 352.754.1117

Toll Free. 1.800.352.9852 (US, Canada Only)

Fax: 352.754.4508

ESCO - The Proper Tools to Keep Your Equipment Moving!

Stay Connected with ESCO...

