



Equipment Supply Company



Parts Breakdown

YAK 44/22 Ton Jack

ESCO #92003



Model #92003

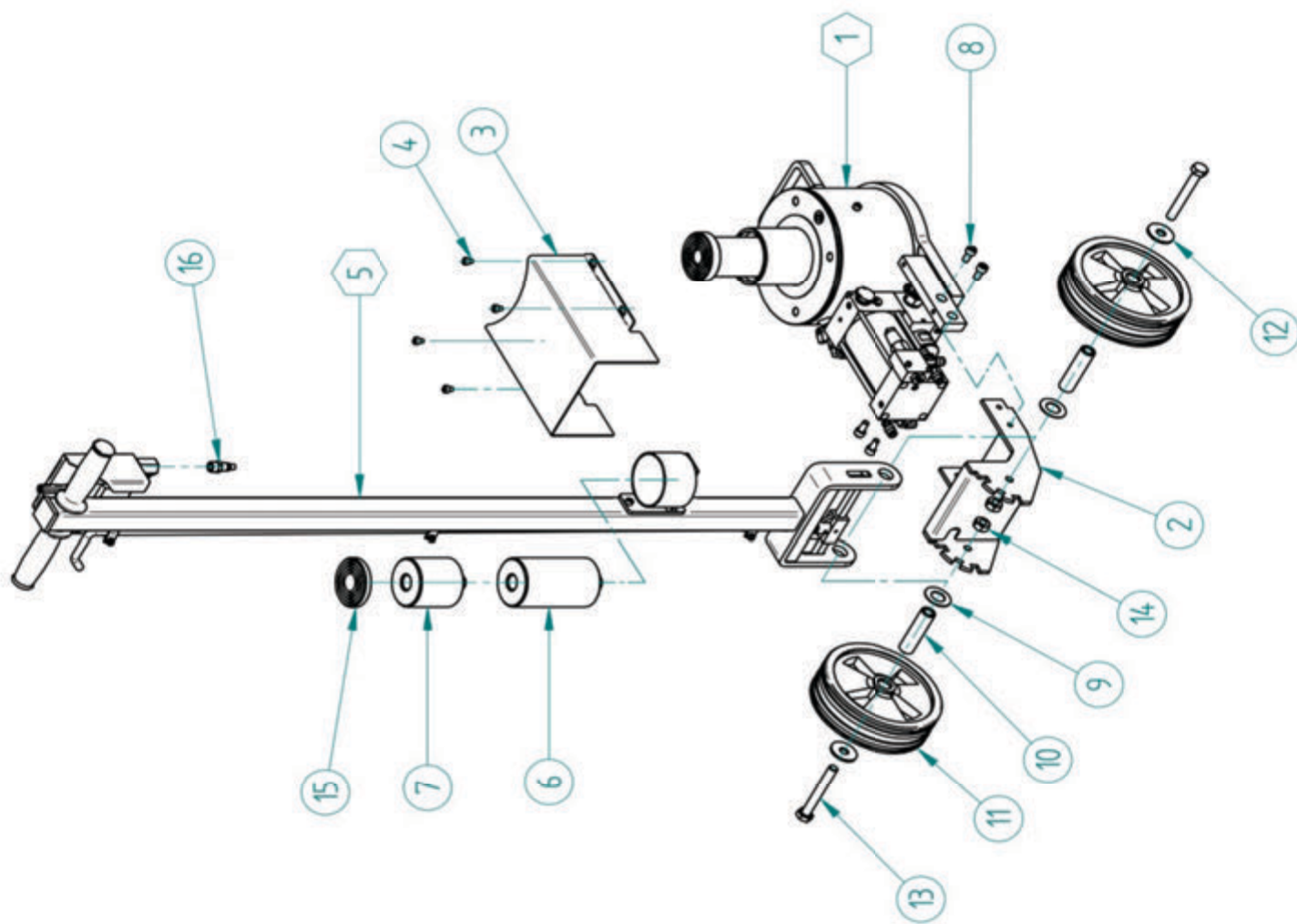

Item N.	Cattini Code	Old Code	Q.ty
1	GRP1SOL-10001	0905	1
2	PS1TELAI-F10001	1078	1
3	PS1CARTE-F10001	1089	1
4	VI0A1FM006X0168-01	14101	4
5	GRP1GRM-10001	0945	1
6	PS1PROLU-F10001	0117	1
7	PS1PROLU-F10002	0116	1
8	VI0A1FM008X0168-01	0302	4
9	RO0R1XM020X037Z-01	0304	2
10	PS1MOZZO-F10001	1083	2
11	RT0GOMF1700020000600N-01	0376	2
12	RO0R1XM012X036Z-01	1295	2
13	VI0A2FM012X090B-01	1289	2
14	DA001XM012X000Z-01	1296	2
15	PS1PIATT-F10001	0115	1
16	RB00F00G1-4AM99N-01	0433	1

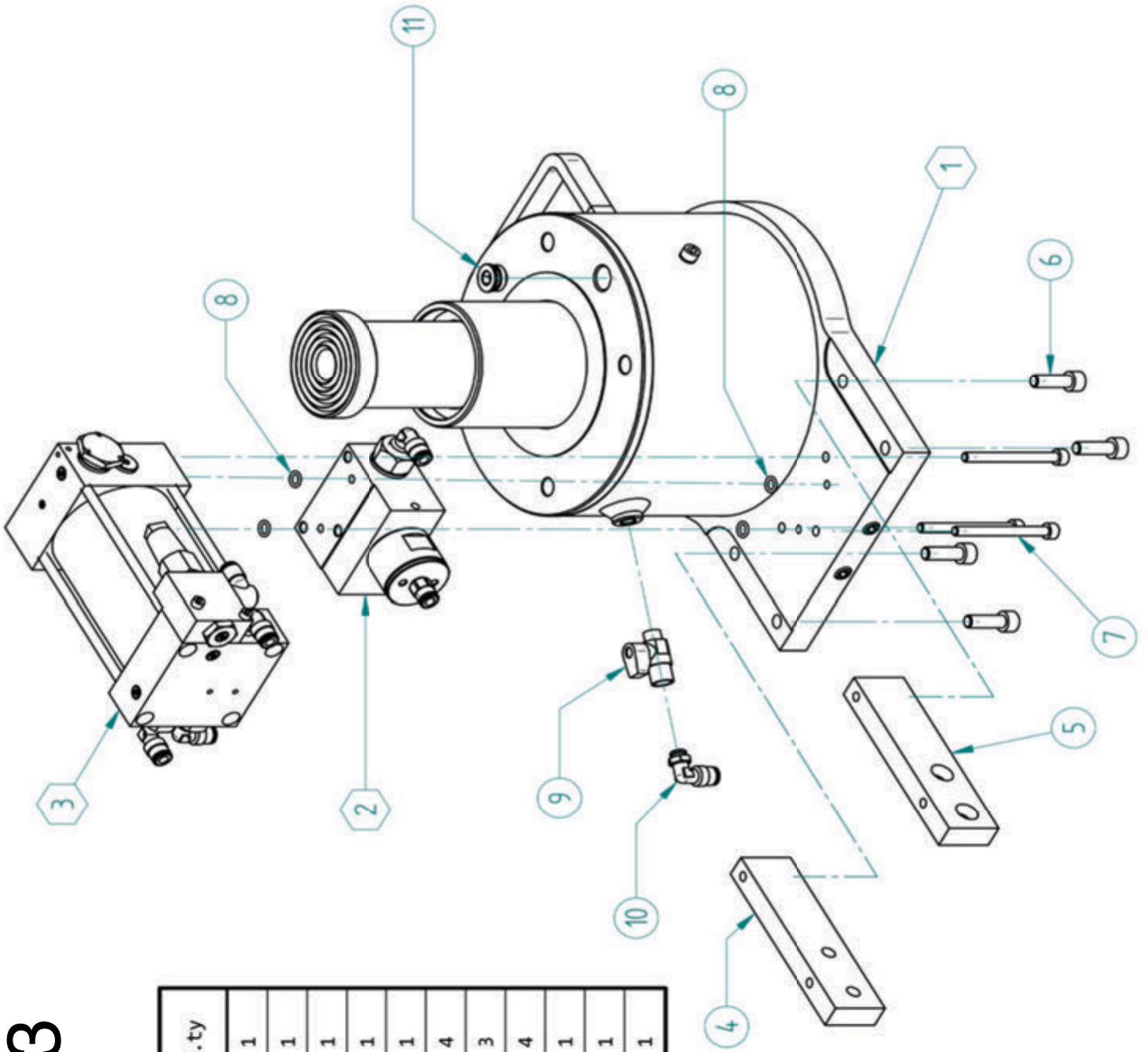

MODEL #92003

Pos.	Code	Old Code	Q.ty
1	GRP1GCI-10001	1054	1
2	GRP1GBL-10001	1052	1
3	GRP1GMP-10018	N.C.	1
4	PS1_LAMA-F10002	1019	1
5	PS1_LAMA-F10003	1022	1
6	VI0A1FM008X025B-01	1121	4
7	VI0A1GM006X065B-01	N.C.	3
8	OR0N700675-0178-00106	0090	4
9	VS00F00G1-8AX99N-01	0843	1
10	RB00R06G1-8BM03T-01	0750	1
11	TA00F00G3-8BM990-01	0795	1

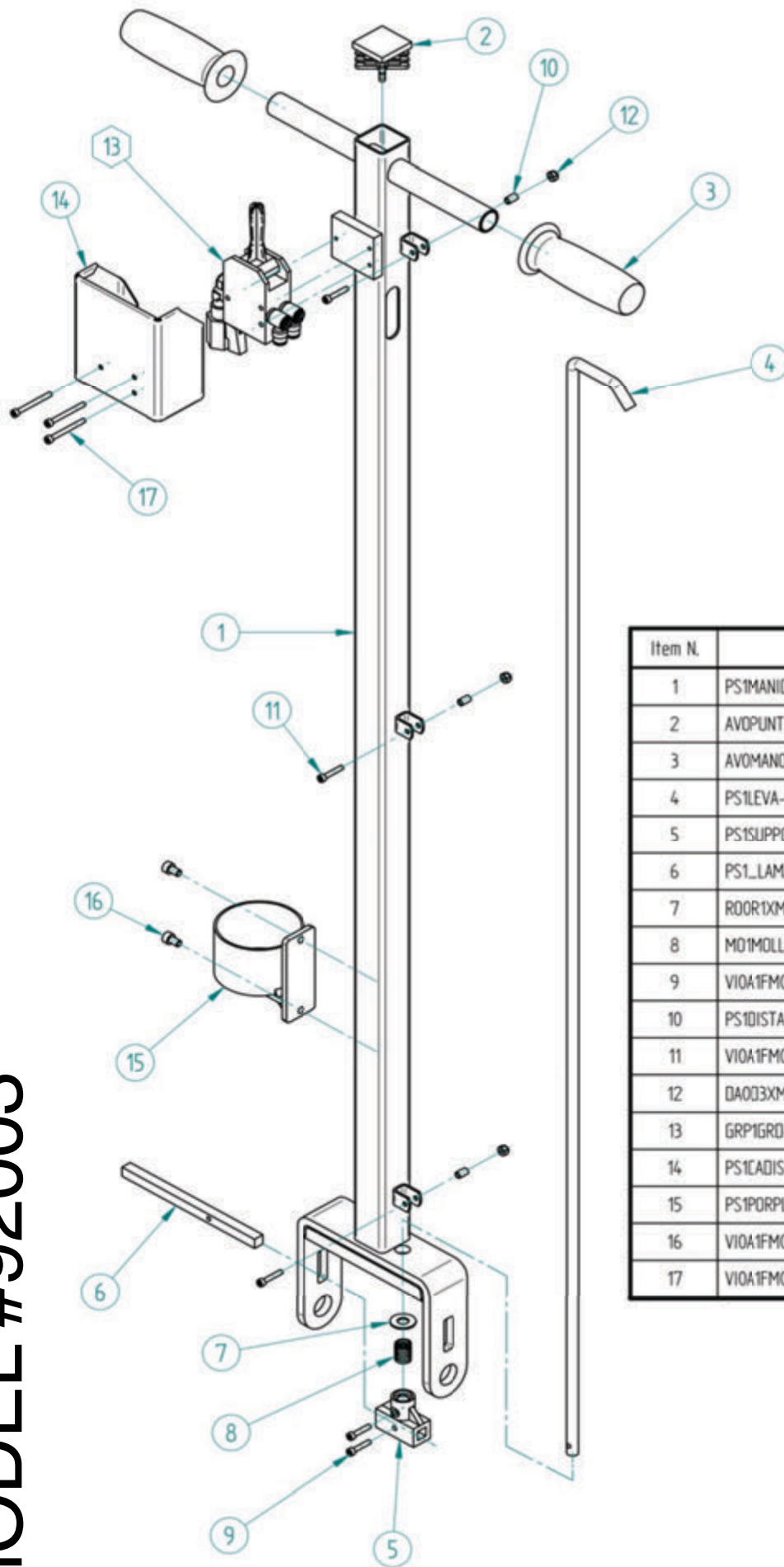

Item N.	Code	Old Code	Qty
1	PS1MANIC-F10001	1098	1
2	AVDPUNT-10001	0385	1
3	AVOMAND-10001	0333	2
4	PS1LEVA-F10001	1092	1
5	PS1SUPPD-F10001	1067	1
6	PS1_LAMA-F10001	1068	1
7	R00R1XM010X022Z-01	1254	1
8	MD1MOLLA-10007	1293	1
9	V10A1FM004X020B-01	0386	2
10	PS1DISTA-F10001	0299	3
11	V10A1FM004X022Z-01	N.C.	3
12	DA003XM004X000Z-01	0831	3
13	GRP1GRD-10001	K00945	1
14	PS1CADIS-F10001psm	1314	1
15	PS1PORPL-F10001	1400	1
16	V10A1FM006X010B-01	1401	2
17	V10A1FM004X040B-01	0380	3

MODEL #92003

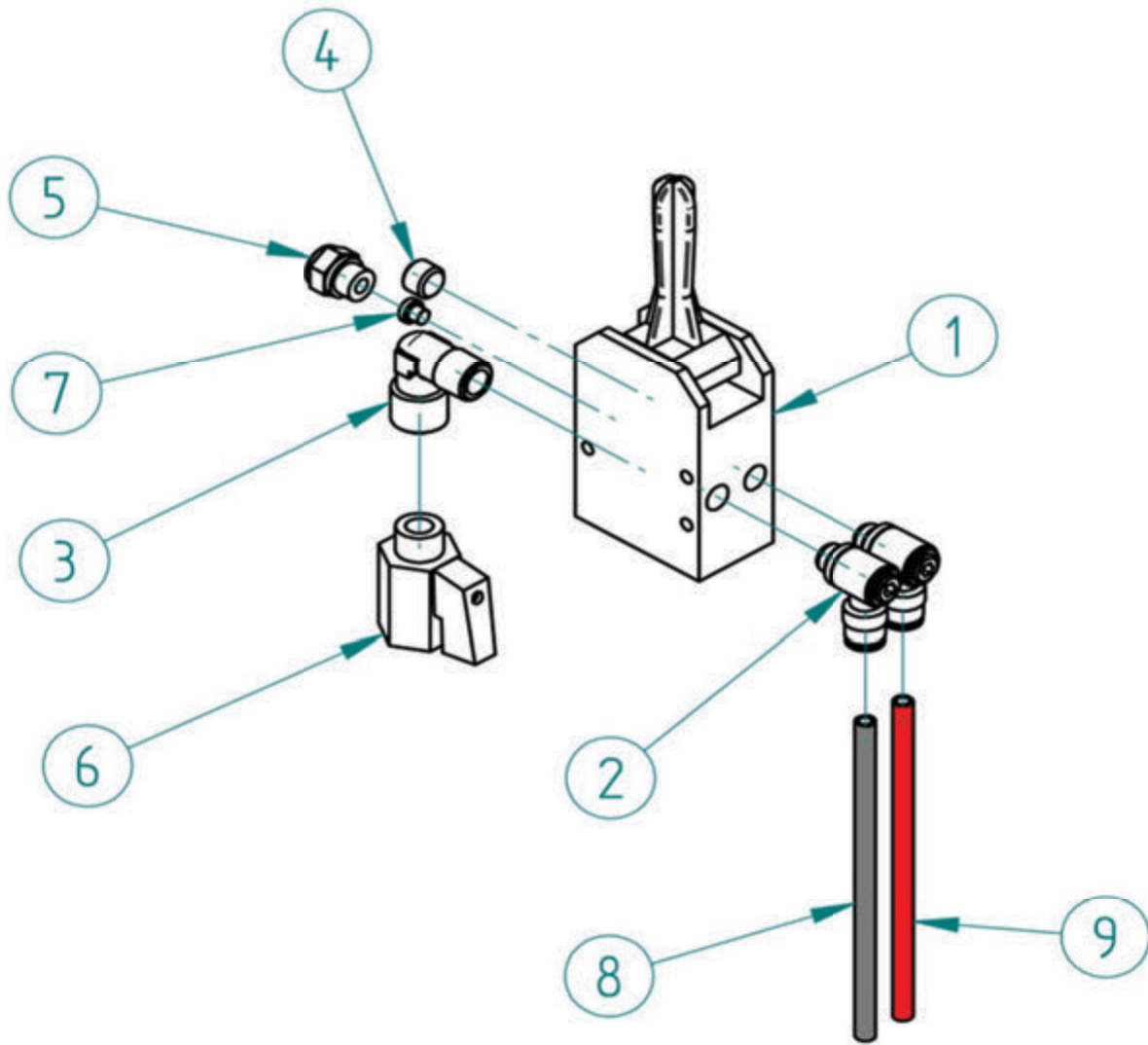

MODEL #92003

Item N.	Code	Old Code	Q.ty
1	VP1M5LG1-4F-01	0378	1
2	RB00R06G1-8BM030-01	0389	2
3	RB00F00G1-4AX02N-01	0314	1
4	GROTCXG018X978B-01	0107	1
5	AVOSILE-10002	0420	1
6	VS00F00G1-4AX99N-01	0398	1
7	TA00F00M005BM990-01	0726	1
8	PS1TRILS-F10004	N.C.	1
9	PS1TRILS-F10005	N.C.	1

Model #92003- Parts Breakdown

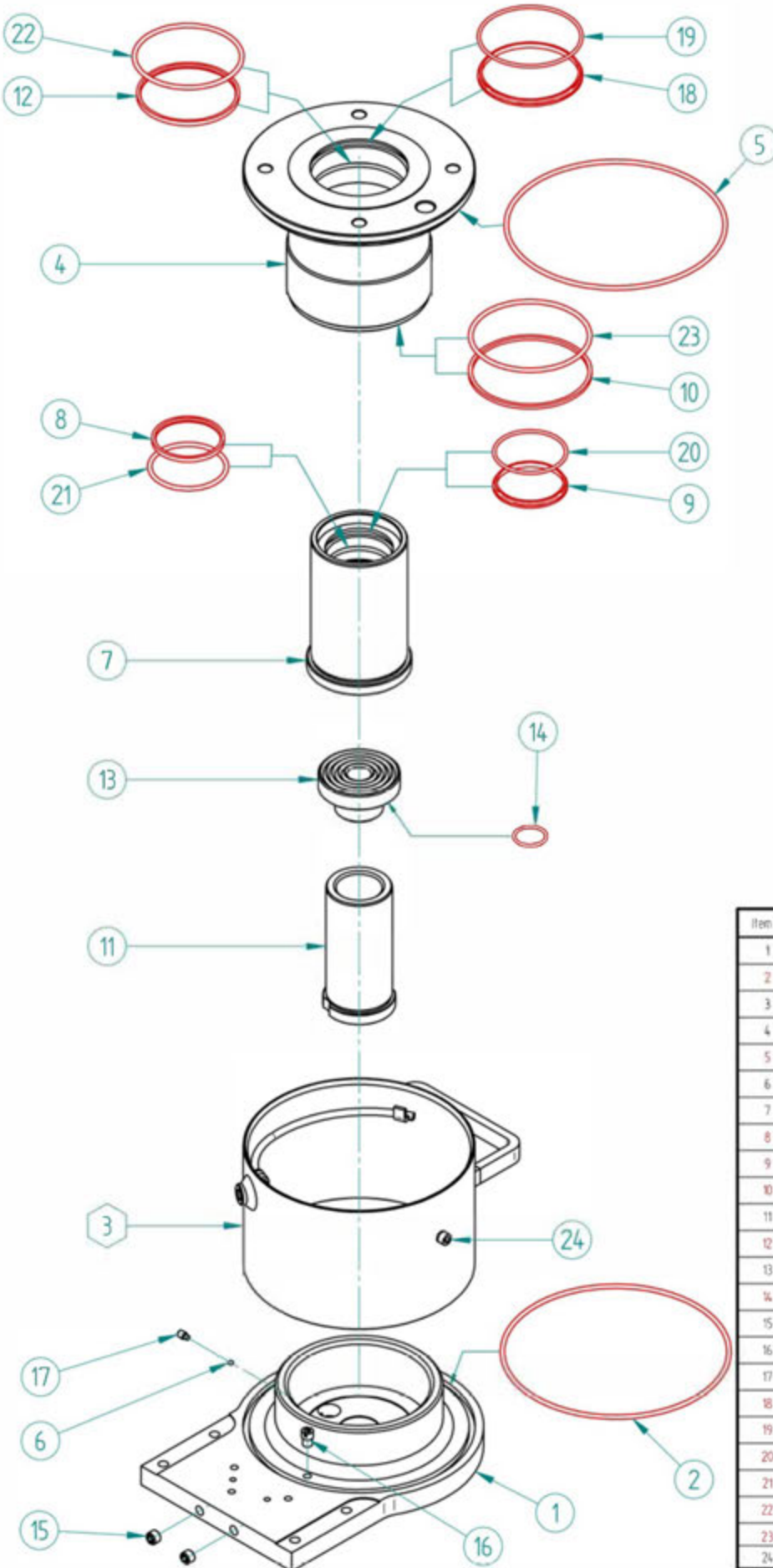

MODEL #92003

Item N	Code	Old Code	Qty
1	PPBASM-10001	1018	1
2	OR0718374-0653-04725	1017	1
3	ERP1GRS-10001	1016	1
4	PPICLOL-10001	1013	1
5	OR0717739-0353-04700	1025	1
6	SFOA5003969-0532A-01	0085	1
7	PPPISTO-10001	1014	1
8	TC006L0550-OR-01	1020	1
9	RS006N0550-OR-01	1021	1
10	TS1NNX1020-OR-01	1527	1
11	PPPISTO-10002	1015	1
12	TC006L0800-OR-01	1024	1
13	PPPIATT-10001	0783	1
14	OR0702381-0262-00102	0075	1
15	GR07CXS018X978B-01	0107	2
16	PS1NPLE-F10001	0844	1
17	GR0614M006X1010B-01	0541	1
18	RS006L0800-OR-01	1023	1
19	OR0708222-0262-03325	N.C.	1
20	OR0705682-0262-03225	N.C.	1
21	OR0705992-0353-04237	N.C.	1
22	OR0708532-0353-04337	2165	1
23	OR0709484-0353-04375	1528	1
24	WDA1FM006X1010B-01	1401	1

MODEL #92003

Item N.	Code	Old Code	Q.ty
1	PP1CPPOM-10011	N.C.	1
2	PSIGUIDA-F10007	2087	1
3	AV1FILT-10002	0719	1
4	T400F00G1-88M990-01	2348	1
5	TC0PEN0060-OR-01	2088	1
6	OR0N700850-0200-0000	N.C.	1
7	PS1_DADO-F10005	2086	1
8	OR0N701877-0178-02075	0709	2
9	OR0N700528-0178-02021	0111	1
10	GRP1GP1-10003	N.C.	1
11	NS1POMTE-10002	2089	1
12	SF0A500925-0038A-01	0040	1
13	MO1MOLLA-10004	0041	1
14	SF0A5014288-0916A-01	0521	1
15	MO1MOLLA-10006	0077	1
16	PS1TAPPO-F10019	0518	1
17	MO1MOLLA-10008	0706	1
18	PP1CLAIR-10001	0704	1
19	GRP1GTE-10005	N.C.	1
20	VI0A1FM006X120Z-01	0703	4
21	OR0N700675-0178-00106	0090	2
22	GRP1GDE-10008	N.C.	1
23	PS1VALVO-F10004	0050	1
24	MO1MOLLA-10009	0051	1
25	PS1_VITE-F10001	0052	1
26	RO0R9X0814X000N-01	0095	1
27	PS1TAPPO-F10014	1112	1
28	SF0A5003969-0532A-01	0085	1
29	GR0G24M006X006B-01	0013	1
30	T400F00M005B0990-01	0726	1
31	VI0A1FM004X040B-01	0300	1
32	VI0A1FM004X030B-01	1290	1
33	AE0ASI0250-01	N.C.	1

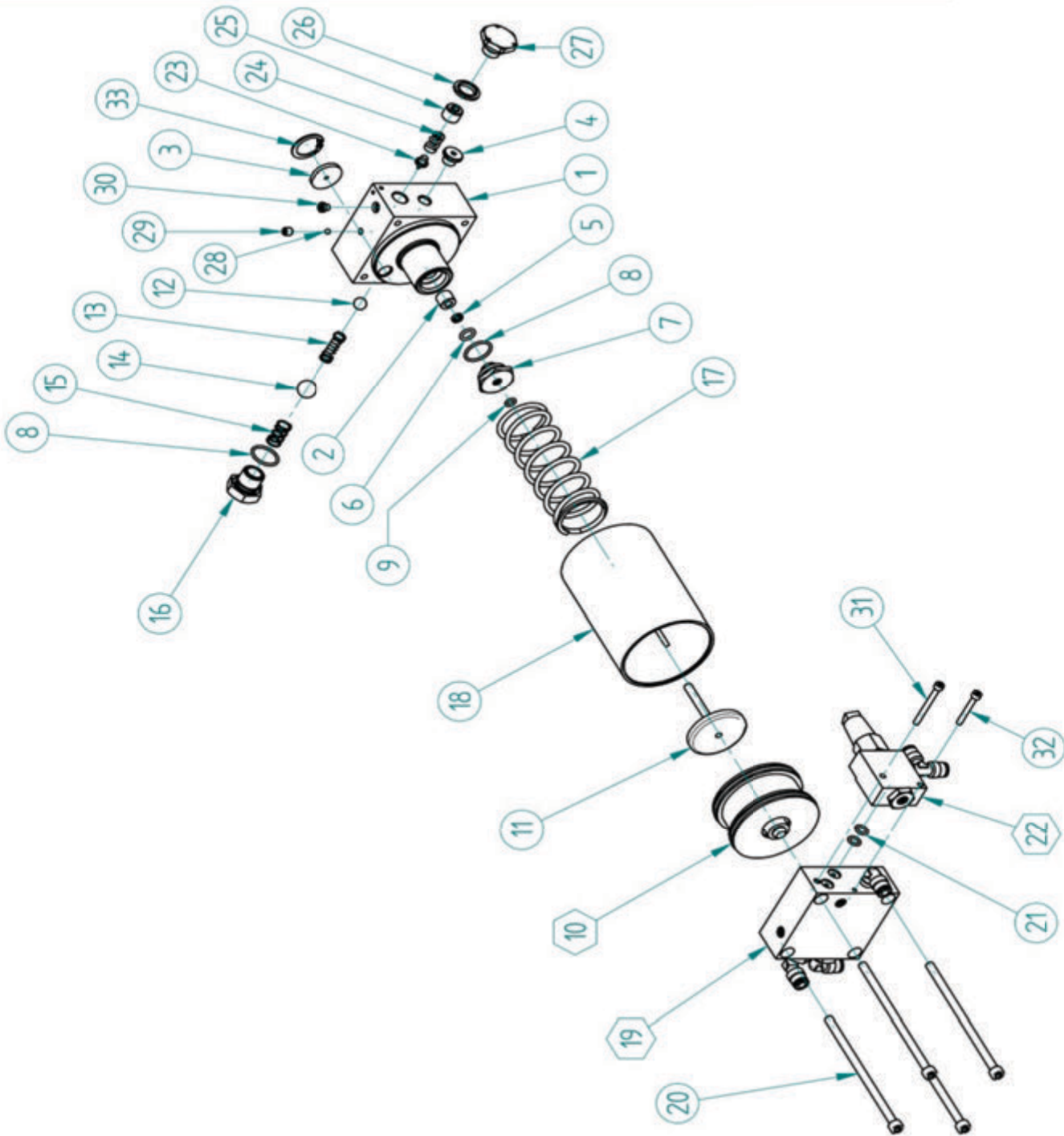

MODEL #92003

Item N.	Code	Old Code	Qty
1	PP1EPAH-10001	1011	1
2	R00R9XG038X000N-01	0033	1
3	PS1VALV-F10002	0088	1
4	PS1PSTO-F10004 0089	0089	1
5	DR0N700675-0178-00106	0090	4
6	R800R0661-44M02T-01	0716	1
7	SF0450095Z5-0038A-01	0040	1
8	M01M0LLA-10005	0108	1
9	R00R9XG014X000N-01	0095	1
10	PS1TAPP0-F10001	1012	1
11	SF045003969-0532A-01	0085	2
12	ER0G24M006X00668-01	0019	2
13	R00R04M022X028N-01	0092	1
14	PS1VALV-F10003	0265	1
15	DR0N701910-0262-00117	0065	1
16	PS1SPILL-F10001	0083	1
17	AE0A110032-01	0094	1
18	M01M0LLA-10002	0084	1
19	PS1PSTPI-F10001	0091	1
20	PS1PSTO-F10002	0264	1
21	PS1PSTO-F10001	0080	1
22	DA001M0005X0000Z-01	0078	1
23	DR0N702340-0953-04093	0026	2
24	PS1TAPP0-F10002	0263	1
25	DR0N702824-0262-03112	0063	1
26	M01M0LLA-10006	0077	1
27	R800R0661-88M01D-01	0140	1

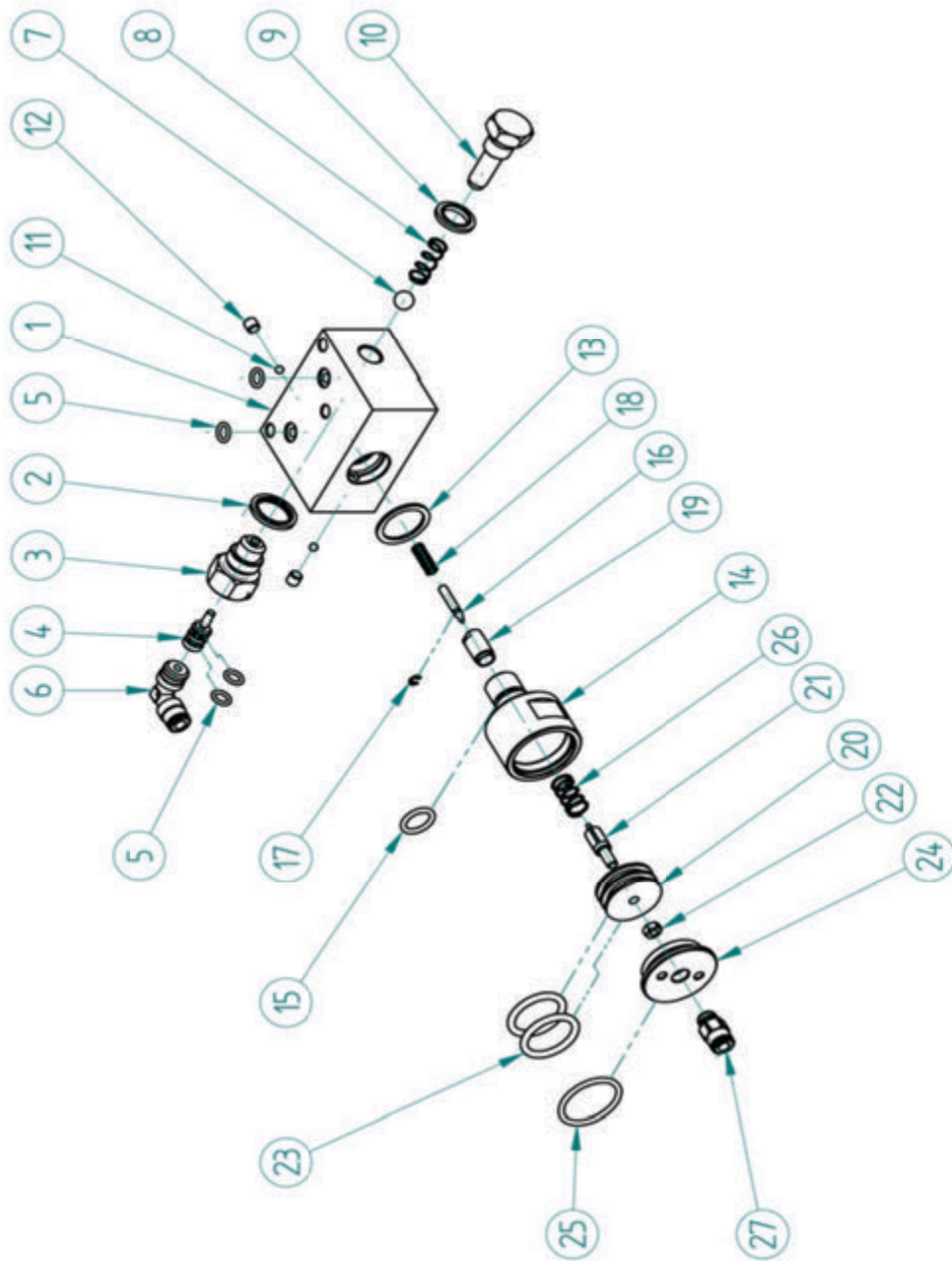

The Proper Tools To Keep Your Equipment **MOVING**



Scan this Code to Go to
the ESCO website

WWW.ESCO.NET



CONTACT INFO:

www.esco.net - info@esco.net
15270 Flight Path Drive
Brooksville, FL 34604
PH. 352.754.1117
Toll Free. 1.800.352.9852 (US, Canada Only)
Fax: 352.754.4508

ESCO - The Proper Tools to Keep Your Equipment Moving!

Stay Connected with ESCO...

