



Hydraulic Transmission Jack

ESCO #10812

(OPERATION INSTRUCTION)

Parts Manual



2 Ton Capacity



WARNING

READ ALL INSTRUCTIONS BEFORE OPERATING THIS JACK TO AVOID MISUSAGE OR SERIOUS INJURY. FOR MORE INFORMATION ON THE CORRECT APPLICATION AND USAGE OF THIS PRODUCT CONTACT THE MANUFACTURER.

Caution

Jack is designed for lifting purpose only. It must not be used as a jack stand to hold load for any prolonged period. Do not move the jack when load is in very high position and is not fixed on saddle stably. The jack should move only on a hard level surface. Do not adjust safety valve. When necessary, return jack to service agent for any adjustment. Do not overload and jack beyond its rated capacity. Do not substitute component parts when jack model is different.

Operating Procedure

Exhausting

- During shipment and handling, especially after a long storage, air probably gets into the hydraulic system, causing poor lifting performance. Exhaust any air from the system before use. Here follow the methods.
- Close release valve (turn knob clockwise as shown). Loosen the air vent plug on the filler, then operate handle until the empty saddle gets to the highest.
- Open the release valve (turn knob counterclockwise). While holding the empty saddle down, operate handle rapidly several times in order to exhaust the air in the system, then press the air vent plug tightly.

Lifting

- Turn the knob clockwise until release valve closes. Do not over tighten the valve.
- Place jack directly and centrally under object to be lifted. Operate the handle up and down within an angle of 60°. The jack can take up load immediately.
- While lifting very heavy objects, the angle to operate handle must be within the limits of 45° so as to avoid damaging parts with the rapid increase of the operating force. (full 360rotating pump handle operates in any position)
- After raising jack to required height: use jack stand(s) to hold load.

Transmission

- Fix load tightly on the saddle with chains.
- Turn the release valve counterclockwise in order to lower the load to lower position (About at the midpoint of the whole lifting height).
- The four handlebars on jack (as shown in the diagram) are used to move jack in any direction on level solid surfaces.

Saddle Adjusting

- For safe and proper use, the saddle can be adjusted according to the load size and angle degrees while disassembling (As shown in the diagram).
- Loosen the four bolts on saddle, adjust the four retaining plate assembly parts to proper position, then twist bolts tightly. The saddle side adjustment is within the limits as shown in the specifications.
- Adjust the two regulating bolts on the saddle, and then the saddle can be side titled within the limits as shown in the specifications. The two bolts must be adjusted simultaneously and harmoniously in order to let the saddle stay in required angle and not away.
- Turn the adjusting hand wheel under saddle. Then the saddle can be titled within the limits from forward to back as shown in the specifications.



Lowering

- Turn the knob counterclockwise until release valve opens. Saddle automatically lowers to its original position. Do not open the release valve too fast, or saddle will go down quickly and do damages to load.

Oiling

- If jack needs re-oiling, take out the air vent plug, inject machine hydraulic oil into the plug. At the same time operate the handle for 3 to 5 times in order to guarantee the inner hydraulic system full of oil. When oil is on a level with the edge under the oil-filling hole, stop oiling and press the air vent plug tightly.

Maintenance Instruction

Before operating the jack, lubricate points (1) to (5) indicated in the diagram:

- A. Wheels: Use light oil on axles and caster bearings.
- B. Saddle and linkages: Use light oil on all moving pivoting parts.
- C. Lifting arm: Inject grease into moving parts.
- D. Handle: Use light oil on moving parts.
- E. Linkage between handle and plunger. Use grease to lubricate it.

Check the hydraulic system: every 4 months to make sure it is free from corrosion. If corrosion is present, clean the parts and remove rust, then re-oil according to the above-mentioned oiling method. Always use good quality hydraulic jack oil. Do not mix the type of oil.

When filling with hydraulic oil do not permit dirt or any other substance to enter the hydraulic system.

Always store the jack with saddle fully Lowered and with release valve open.

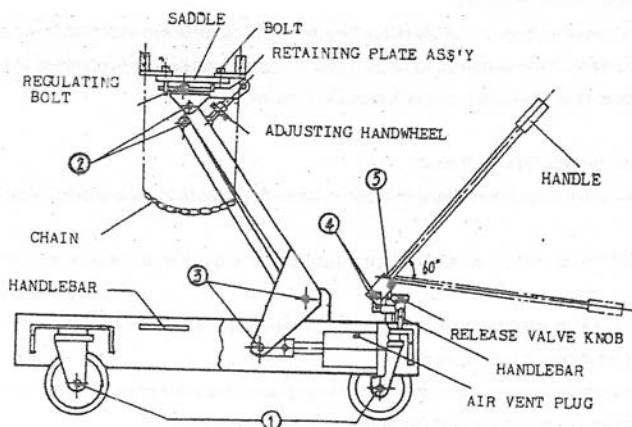

	Capacity		Lift Range		Saddle Size Adjustment		Castor	Chassis Size	Saddle Tilt	Net Weight
	Tons		Low	High	Min.	Max.				
#10812	2		9"	35"	12.6" x 7.5"	16.5" x 11.4"	DLA.	Length	Width	Lbs.
							4"	44.7"	26"	297 lbs.



#10812 PARTS BREAKDOWN AND PARTS LIST

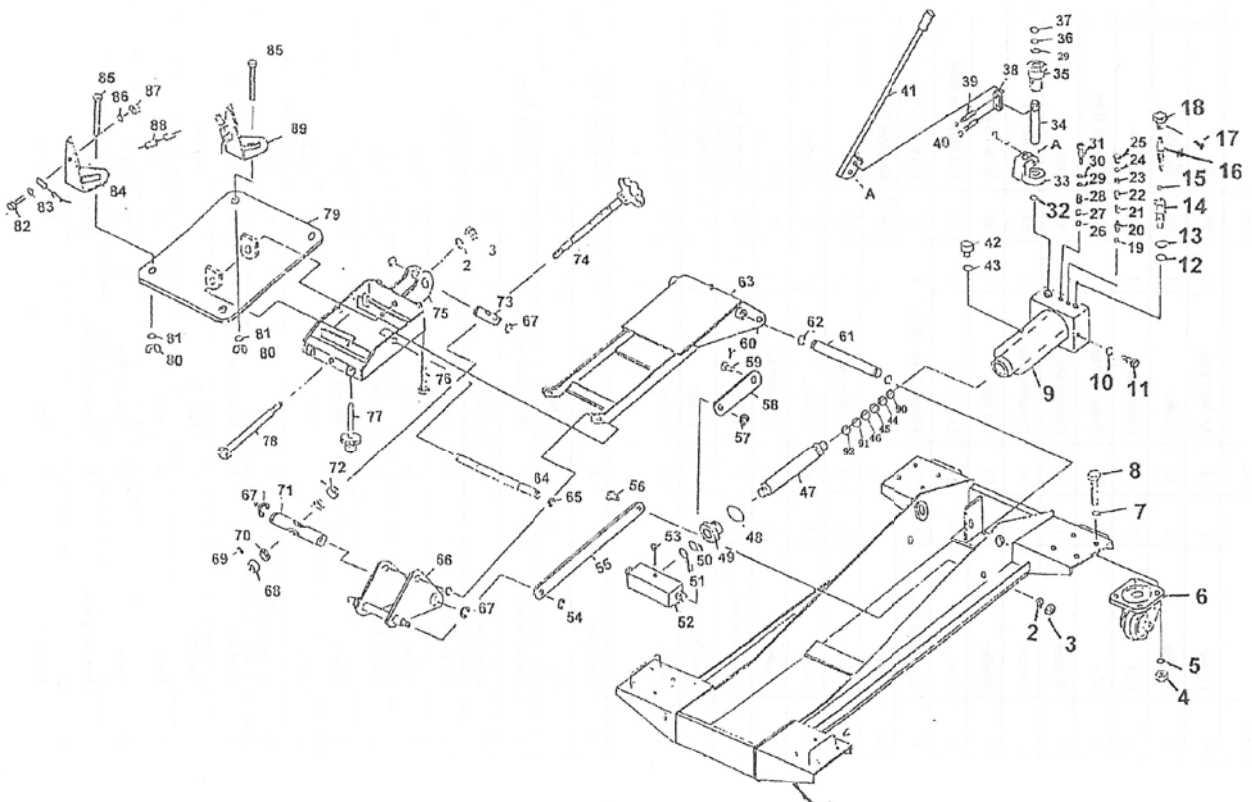



#10812 PARTS BREAKDOWN AND PARTS LIST (cont.)

Part No.1	Description	Qty	Part No.	Description	Qty	Part No.	Description	Qty
1	Frame	1	31	Air Vent Plug	1	59	Pin	2
2	Washer	2	32	Washer	1	60	Split Pin	2
3	Nut	2	33	Handle Fork	1	61	Arm Pin	1
4	Nut	16	34	Pump Plunger	1	62	Back-up Ring	2
5	Washer	16	35	Plunger Sleeve	1	63	Arm	1
6	Castor	4	36	Retaining Ring	1	64	Link rod pin	4
7	Washer	16	37	Oil seal	1	65	Back-up Ring	1
8	Bolt	16	38	Lug	2	66	Lift platform stand	4
9	Hydraulic Unit	1	39	Plunge Connecting Pin	6	67	Back-up Ring	1
10	Washer	2				68	Oriented Nut	4
11	Bolt	2	40	Back-up Ring	1	69	Screw	2
12	Washer	1	41	Handle	1	70	Bearing	2
13	O-ring	1	42	Air vent plug	1	71	Pin	1
14	Release Valve	1	43	O-ring	1	72	Oriented Nut	1
	Lock Nut		44	Washer	1	73	Connecting Shaft	1
15	O-ring	1	45	O-ring	1	74	Long adjusting Screw	1
16	Valve Rod	1	46	Back-up ring	1	75	Supporting Stand	1
17	Pin	1		Retainer		76	Bolt	2
18	Handle Wheel	1	47	Piston Rod	1	77	Adjusting Screw	2
19	Steel Ball	1	48	O-ring	1	78	Bolt	1
20	Spring Back-up	1	49	Tank nut	1	79	Lift platform	1
21	Spring	1	50	O-ring	1	80	Nut	4
22	Spring Back-up	1	51	Oil seal	1	81	Washer	4
23	Retainer	1	52	Piston Connecting Joint	1	82	Bolt	2
24	O-ring	1				83	Washer	2
25	Air Vent Plug	1	53	Pin	1	84	Stand	2
26	Steel Ball	1	54	Back-up Ring	2	85	Adjustable screw	4
27	Steel Ball	1	55	Link Rod	2	86	Washer	2
28	Spring	1	56	Screw	2	87	Nut	2
29	O-ring	2	57	Back-up Ring	2	88	Chain	2
30	Retaining Ring	1	58	Connecting plate	2	89	Stand	2
90	Back-up ring	1	91	Bush	1	92	O-ring	1