

Installation and Instruction Manual

ESCO PART # 10543

Calcium Chloride Pump



WARNING

SAFETY PRECAUTION

This product, as well as all Tire Tools, should never be used by persons unless they have been trained properly according to O.S.H.A. Regulation #29CFR 1910.177 entitled "Servicing Single-Piece & Multi-piece Rim Wheels." Copy of the Regulation is enclosed or contact this manufacturer.

SAFETY CAGE OR RESTRAINING DEVICE FROM O.S.H.A. REQUIREMENTS AS WRITTEN IN #29CFR 1910.177 SERVICING MULTIPIECE AND SINGLE PIECE RIM/ TIRES

(D) TIRE SERVICING EQUIPMENT

- (1) The employer shall furnish a restraining device for inflation tires on all multi-piece and single piece wheels.
- (2) The employer shall provide a restraining device or barrier for inflation tires on single piece wheels unless the rim wheel will be bolted onto a vehicle during inflation.
- (3) Restraining devices and barriers shall comply with the following requirements:
 - (i) Each restraining device or barrier shall have the capacity to withstand the maximum force that would be transferred to it during a rim wheel separation occurring at 150 percent of the maximum tire specification pressure for the type of rim wheel being serviced.
 - (ii) Restraining device and barriers shall be capable of preventing the rim wheel components from being thrown outside or beyond the device or barrier for any rim wheel positioned within or behind the device;
 - (iii) Restraining devices and barriers shall be visually inspected prior to each day's use and after any separation of the rim wheel components or sudden release of contained air.



15270 Flight Path Drive | Brooksville, FL 34604

Phone (352) 754-1117 | Toll Free (800) 352-9852 | Fax (352) 754-4508

Web Site: www.esco.net | Email Address: sales@esco.net



10543 CALCIUM CHLORIDE PUMP

OPERATION MANUAL

Husky[®] 1050 Air-Operated Diaphragm Pump

1-inch pump with modular air valve for fluid transfer applications

125 psi (0.86 MPa, 8.6 bar) Maximum Fluid Working Pressure

125 psi (0.86 MPa, 8.6 bar) Maximum Air Input Pressure



Important Safety Instructions

Read all warnings and instructions in this manual. Save these instructions.

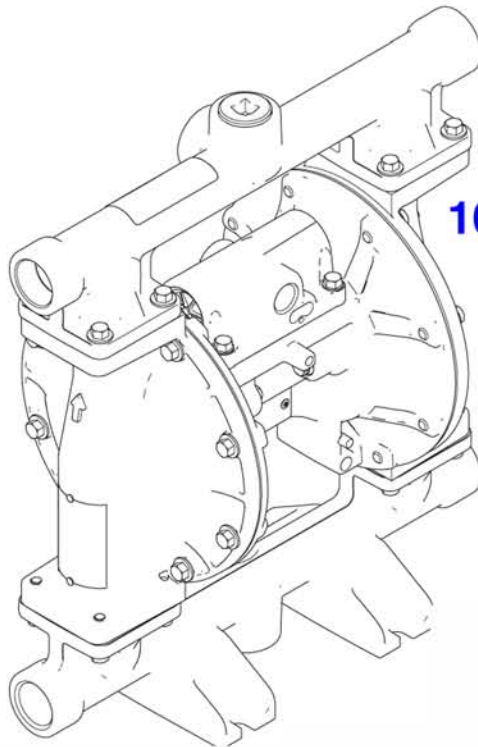

1050A Aluminum





H003





15270 Flight Path Drive • Brooksville, FL 34604

Phone (352) 754-1117 • Toll Free (800) 352-9852 • Fax (352) 754-4508 • www.esco.net • sales@esco.net

Warnings

The following warnings are for the setup, use, grounding, maintenance, and repair of this equipment. The exclamation point symbol alerts you to a general warning and the hazard symbol refers to procedure-specific risk. Refer back to these warnings. Additional, product-specific warnings may be found throughout the body of this manual where applicable.

 WARNING	
	<p>FIRE AND EXPLOSION HAZARD</p> <p>Flammable fumes, such as solvent and paint fumes, in work area can ignite or explode. To help prevent fire and explosion:</p> <ul style="list-style-type: none">• Use equipment only in well ventilated area.• Eliminate all ignition sources; such as pilot lights, cigarettes, portable electric lamps, and plastic drop cloths (potential static arc).• Keep work area free of debris, including solvent, rags and gasoline.• Do not plug or unplug power cords, or turn power or light switches on or off when flammable fumes are present.• Ground all equipment in the work area. See Grounding instructions.• Use only grounded hoses.• Hold gun firmly to side of grounded pail when triggering into pail.• If there is static sparking or you feel a shock, stop operation immediately. Do not use equipment until you identify and correct the problem.• Keep a working fire extinguisher in the work area. <p>Static charge may build up on plastic parts during cleaning and could discharge and ignite flammable materials and gases. To help prevent fire and explosion:</p> <ul style="list-style-type: none">• Clean plastic parts in a well ventilated area.• Do not clean with a dry cloth.

 WARNING	
	<p>TOXIC FLUID OR FUMES HAZARD</p> <p>Toxic fluids or fumes can cause serious injury or death if splashed in the eyes or on skin, inhaled, or swallowed.</p> <ul style="list-style-type: none">• Read MSDS's to know the specific hazards of the fluids you are using.• Route exhaust away from work area. If diaphragm ruptures, fluid may be exhausted with air.• Store hazardous fluid in approved containers, and dispose of it according to applicable guidelines.• Always wear impervious gloves when spraying or cleaning equipment.
	<p>BURN HAZARD</p> <p>Equipment surfaces and fluid that's heated can become very hot during operation. To avoid severe burns:</p> <ul style="list-style-type: none">• Do not touch hot fluid or equipment.• Wait until equipment/fluid has cooled completely.
	<p>PERSONAL PROTECTIVE EQUIPMENT</p> <p>You must wear appropriate protective equipment when operating, servicing, or when in the operating area of the equipment to help protect you from serious injury, including eye injury, inhalation of toxic fumes, burns, and hearing loss. This equipment includes but is not limited to:</p> <ul style="list-style-type: none">• Clothing and respirator as recommended by the fluid and solvent manufacturer• Protective eyewear, gloves, and hearing protection

Installation





The Typical Installations shown in FIG. 3 and FIG. 4 are only guides for selecting and installing system components. Contact your **ESCO** distributor for assistance in planning a system to suit your needs.

Tighten Fasteners Before Setup

Before using the pump for the first time, check and retorquing all external fasteners.



WARNING

	<p>EQUIPMENT MISUSE HAZARD</p> <p>Misuse can cause death or serious injury.</p> <ul style="list-style-type: none">• Do not operate the unit when fatigued or under the influence of drugs or alcohol.• Do not exceed the maximum working pressure or temperature rating of the lowest rated system component. See Technical Data in all equipment manuals.• Use fluids and solvents that are compatible with equipment wetted parts. See Technical Data in all equipment manuals. Read fluid and solvent manufacturer's warnings. For complete information about your material, request MSDS from distributor or retailer.• Do not leave the work area while equipment is energized or under pressure. Turn off all equipment and follow the Pressure Relief Procedure in this manual when equipment is not in use.• Check equipment daily. Repair or replace worn or damaged parts immediately with genuine manufacturer's replacement parts only.• Do not alter or modify equipment.• Use equipment only for its intended purpose. Call your distributor for information.• Route hoses and cables away from traffic areas, sharp edges, moving parts, and hot surfaces.• Do not kink or over bend hoses or use hoses to pull equipment.• Keep children and animals away from work area.• Comply with all applicable safety regulations.
	<p>PRESSURIZED EQUIPMENT HAZARD</p> <p>Fluid from the gun/dispense valve, leaks, or ruptured components can splash in the eyes or on skin and cause serious injury.</p> <ul style="list-style-type: none">• Follow Pressure Relief Procedure in this manual, when you stop spraying and before cleaning, checking, or servicing equipment.• Tighten all fluid connections before operating the equipment.• Check hoses, tubes, and couplings daily. Replace worn or damaged parts immediately.
	<p>PRESSURIZED ALUMINUM PARTS HAZARD</p> <p>Use of fluids that are incompatible with aluminum in pressurized equipment can cause serious chemical reaction and equipment rupture. Failure to follow this warning can result in death, serious injury, or property damage.</p> <ul style="list-style-type: none">• Do not use 1,1,1-trichloroethane, methylene chloride, other halogenated hydrocarbon solvents or fluids containing such solvents.• Many other fluids may contain chemicals that can react with aluminum. Contact your material supplier for compatibility.
	<p>PLASTIC PARTS CLEANING SOLVENT HAZARD</p> <p>Use only compatible water-based solvents to clean plastic structural or pressure-containing parts. Many solvents can degrade plastic parts and cause them to fail, which could cause serious injury or property damage. See Technical Data in this and all other equipment instruction manuals. Read fluid and solvent manufacturer's warnings.</p>

Maintenance:

Flush pump with fresh water after each use to prolong life.

No lubrication required. Periodically drain debris from filter/regulator bowl. Periodically inspect pump for excessive wear or damage, mainly to the diaphragms, check balls, and valve seats.

Operation:

Install air regulator provided into 1/2" NPT opening in top of pump.

Install muffler into 3/4" NPT opening in bottom of pump.

Connect air supply to air inlet side of pump and set pressure to 40 - 60 p.s.i. Speed of pump is determined by pressure to pump. (Do not exceed 100 p.s.i.) The fluid direction (fill or evac) of pump is controlled by turning the blue handle on the valve at top of pump a 1/4 turn left or right. Neutral is in center. As tire is being filled, the pressure inside the tire will increase. To release internal tire pressure, turn the valve a 1/4 turn to the evacuation position till pressure is relieved. The resume filling tire until full to valve.

Caution:

Do not exceed recommended air pressure for the tire being filled. (Over inflation of the tire can result in personal injury).

To Fill Tires:

Valve Stem Level (Approximately 80% Fill)

- Turn tire until valve is at 12 o'clock position.
- See that the supply hose (10 ft. length) is in calcium tank, well below the liquid level.
- Connect air supply to pump, start pump. During filling, the tire pressure can be checked at any time by turning Neutral position. Pressure shown on pressure gauge.
- Continue filling until tire is half full of liquid. This can be determined by tapping tire sidewall or by checking the amount of liquid pumped against total quality. Turn control to Evacuate and allow trapped air to vent out through overflow than turn clock back to **FILL** direction.
- Continue to fill until liquid is slightly beyond stem level.

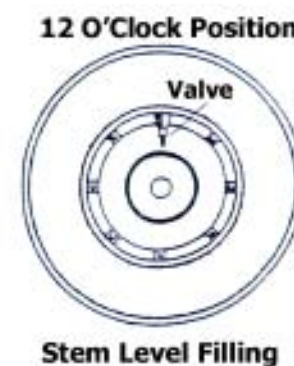

Mounting



- The pump exhaust air may contain contaminants. Ventilate to a remote area.
- Never move or lift a pump under pressure. If dropped, the fluid section may rupture. Always follow the **Pressure Relief Procedure**

1. Be sure the mounting surface can support the weight of the pump, hoses, and accessories, as well as the stress caused during operation.
2. For all mountings, be sure the pump is bolted directly to the mounting surface.
3. For ease of operation and service, mount the pump so air valve, air inlet, fluid inlet and fluid outlet ports are easily accessible.

Grounding



The equipment must be grounded. Grounding reduces the risk of static and electric shock by providing an escape wire for the electrical current due to static build up or in the event of a short circuit.

Pump: See FIG. 1. Loosen the grounding screw (GS). Insert one end of a 12 ga. minimum ground wire (R) behind the grounding screw and tighten the screw securely. Connect the clamp end of the ground wire to a true earth ground.

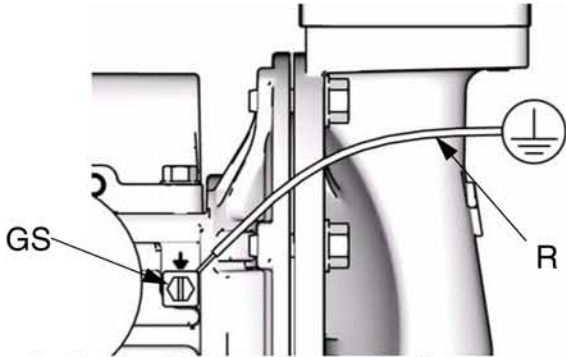

FIG. 1. Grounding screw and wire

Air and fluid hoses: Use only grounded hoses with a maximum of 500 ft (150 m) combined hose length to ensure grounding continuity.

Air compressor: Follow manufacturer’s recommendations.

Fluid supply container: Follow local code.

Solvent pails used when flushing: Follow local code. Use only conductive metal pails, placed on a grounded surface. Do not place the pail on a nonconductive surface, such as paper or cardboard, which interrupts grounding continuity.



Check your system electrical continuity after the initial installation, and then set up a regular schedule for checking continuity to be sure proper grounding is maintained.

Air Line

1. Install an air regulator (C) and gauge to control the fluid pressure. The fluid stall pressure will be the same as the setting of the air regulator.
2. Locate a bleed-type master air valve (B) close to the pump and use it to relieve trapped air. Be sure the valve is easily accessible from the pump and located downstream from the regulator.



3. Locate another master air valve (E) upstream from all air line accessories and use it to isolate them during cleaning and repair.
4. An air line filter (F) removes harmful dirt and moisture from the compressed air supply.
5. Install a grounded, flexible air hose (A) between the accessories and the 1/2 npt(f) pump air inlet (D). Use a minimum 3/8 in. (10 mm) ID air hose.

Air Exhaust Ventilation



The air exhaust port is 3/4 npt(f). Do not restrict the air exhaust port. Excessive exhaust restriction can cause erratic pump operation.

To provide a remote exhaust:

1. Remove the muffler (T) from the pump air exhaust port.
2. Install a grounded air exhaust hose (U) and connect the muffler (T) to the other end of the hose. The minimum size for the air exhaust hose is 3/4 in. (19 mm) ID. If a hose longer than 15 ft (4.57 m) is required, use a larger diameter hose. Avoid sharp bends or kinks in the hose.
3. Place a container at the end of the air exhaust line to catch fluid in case a diaphragm ruptures. If the diaphragm ruptures, the fluid being pumped will exhaust with the air.



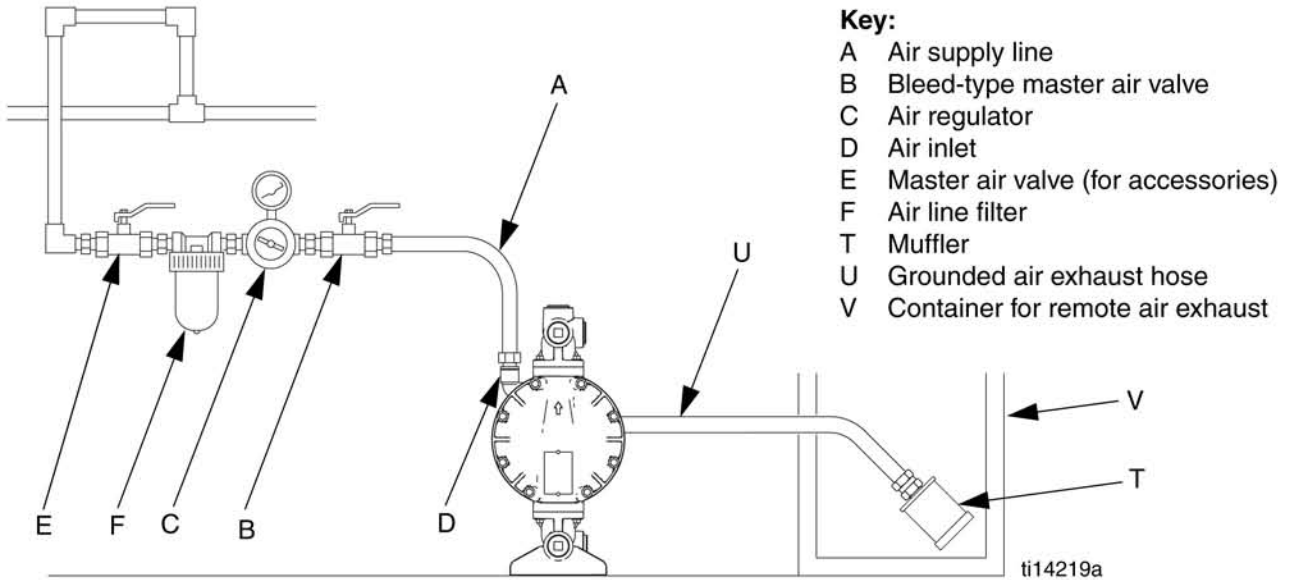

FIG. 2. Vent exhaust air

Fluid Supply Line

See FIG. 3 and FIG. 4.

1. Use grounded fluid supply lines (G). See **Grounding**, page 7.
2. If the inlet fluid pressure to the pump is more than 25% of the outlet working pressure, the ball check valves will not close fast enough, resulting in inefficient pump operation.
3. At inlet fluid pressures greater than 15 psi (0.1 MPa, 1 bar), diaphragm life will be shortened.
4. For maximum suction lift (wet and dry), see **Technical Data**

Fluid Outlet Line

See FIG. 3 and FIG. 4

1. Use grounded fluid hoses (L). See **Grounding**
2. Install a fluid drain valve (J) near the fluid outlet.
3. Install a shutoff valve (K) in the fluid outlet line.

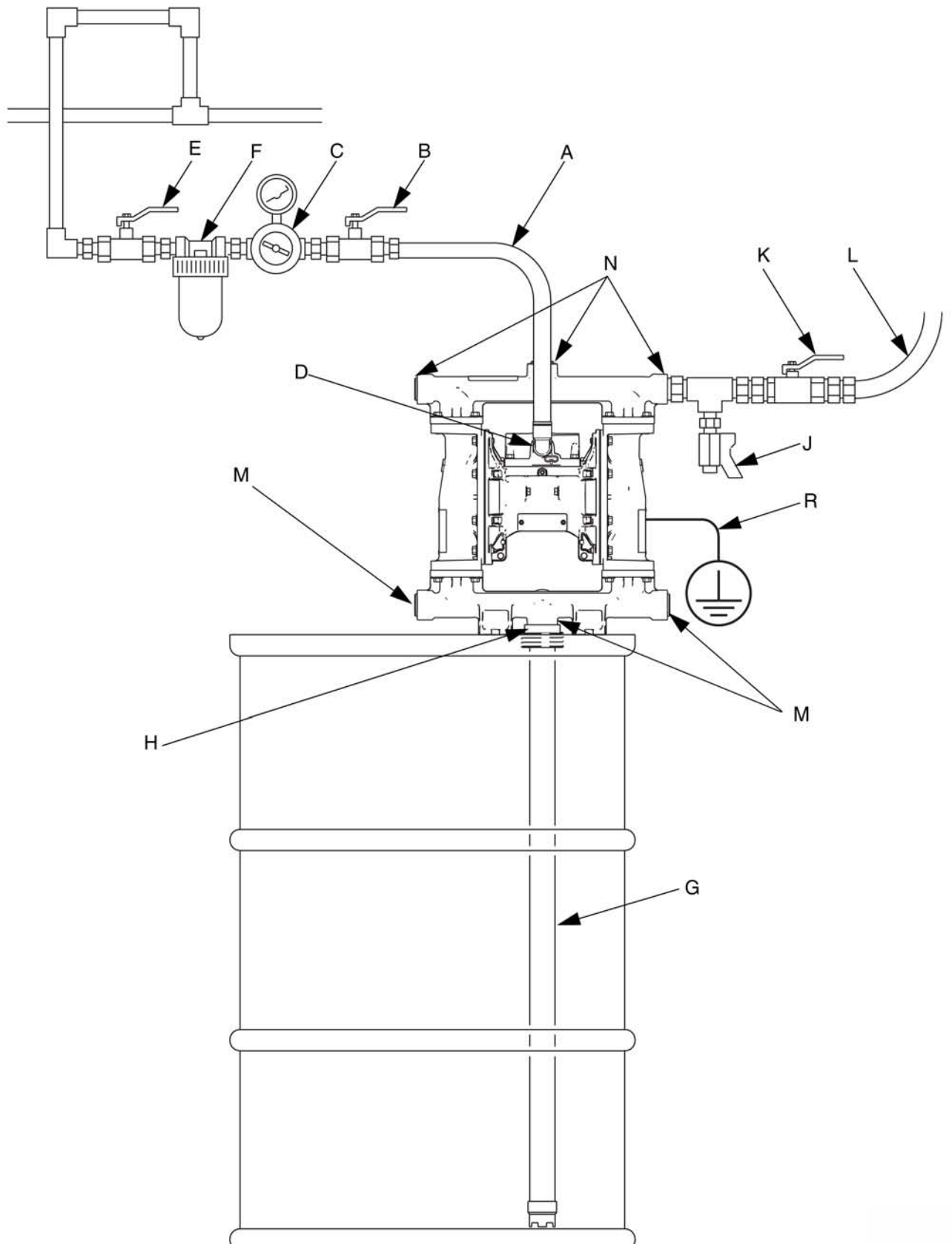

FIG. 3. Typical bung-mount installation (aluminum, 1050A, pump shown)

Performance Charts

Test Conditions: Pump tested in water with inlet submerged.

Operating Air Pressure

- A**
125 psi (0.83 MPa, 8.3 bar)
- B**
100 psi (0.7 MPa, 7.0 bar)
- C**
70 psi (0.48 MPa, 4.8 bar)
- D**
40 psi (0.28 MPa, 2.8 bar)

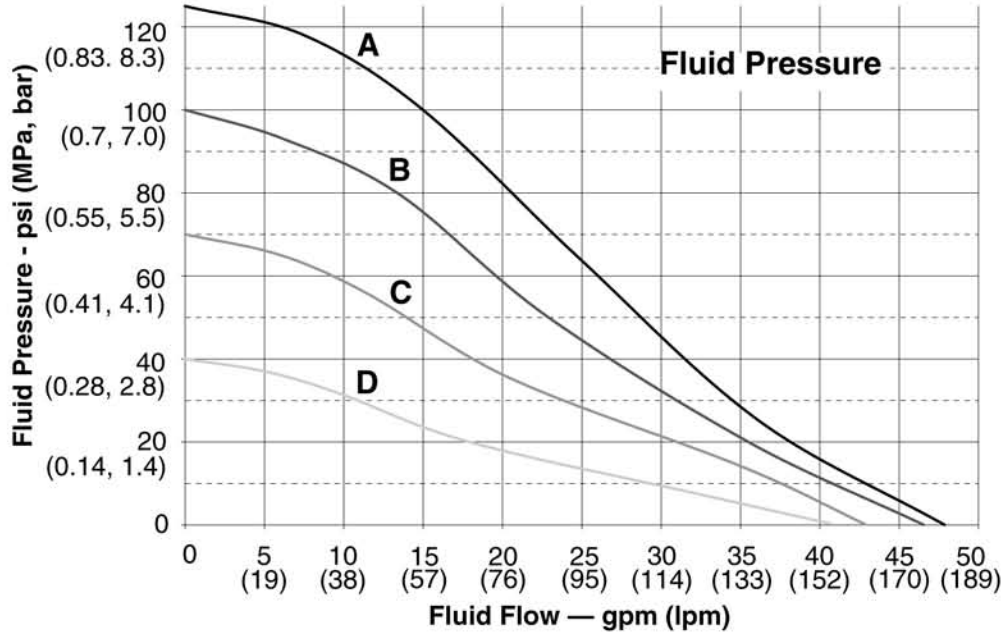

How to Read the Charts

1. Locate fluid flow rate along bottom of chart.
2. Follow vertical line up to intersection with selected operating air pressure curve.
3. Follow left to scale to read **fluid outlet pressure** (top chart) or **air consumption** (bottom chart).

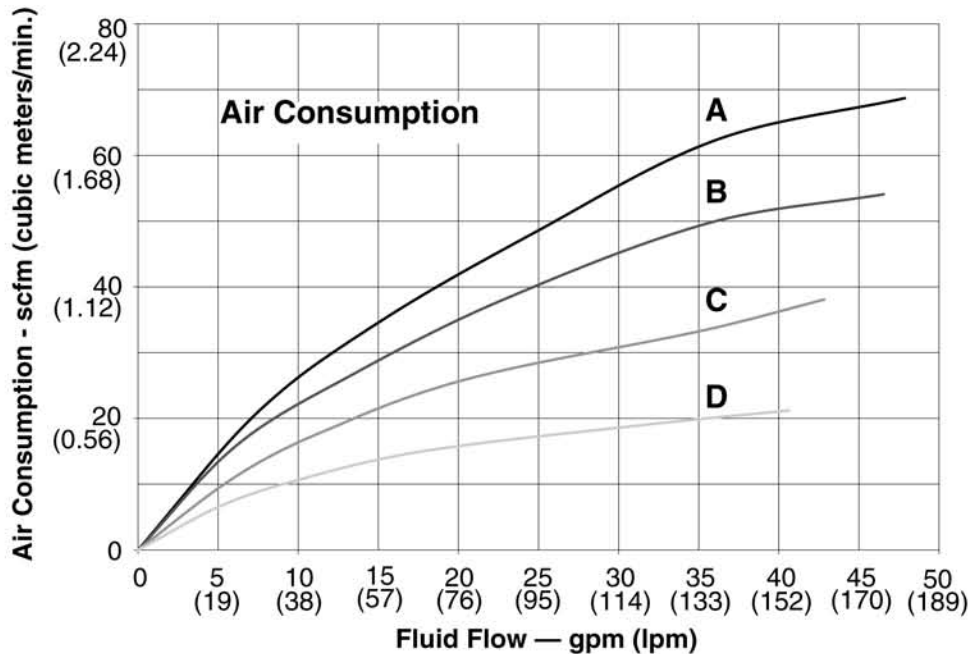

Dimensions and Mounting

Aluminum (1050A)

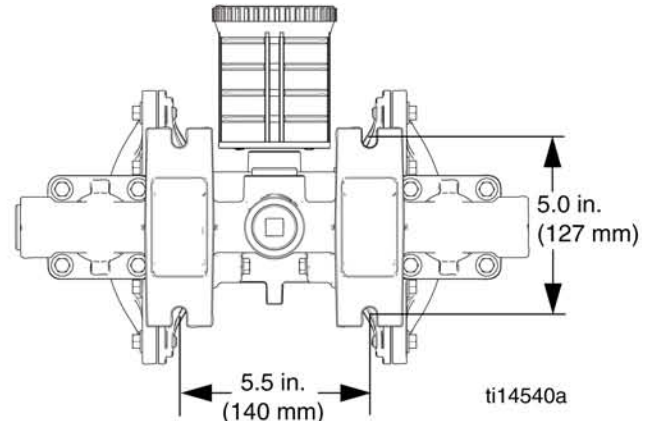
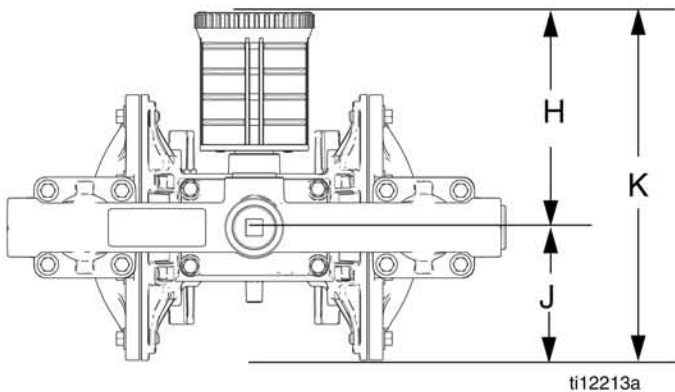
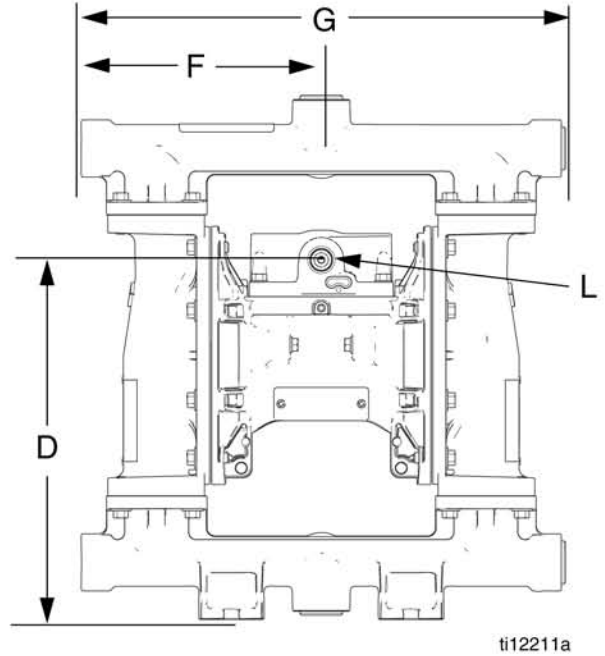
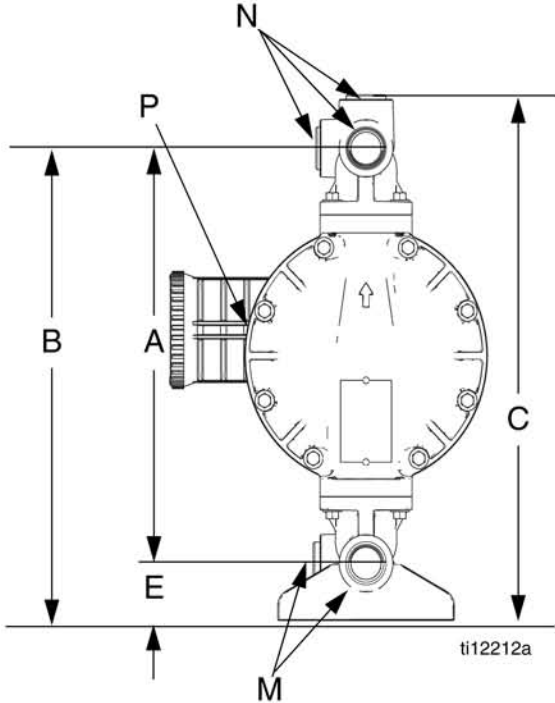

- A** 12.7 in. (323 mm)
- B** 14.4 in. (366 mm)
- C** 15.9 in. (404 mm)
- D** 10.9 in. (277 mm)
- E**..... 1.8 in. (46 mm)
- F**..... 7.3 in. (185 mm)
- G** 14.7 in. (373 mm)
- H** 6.1 in. (155 mm)

- J** 3.9 in. (99 mm)
- K**..... 10.0 in. (254 mm)
- L** 1/2 npt(f) air inlet
- M** ... 1 in. npt(f) or 1 in. bspt fluid inlet ports (4)
- N**..... 1 in. npt(f) or 1 in. bspt fluid outlet ports (4)
- P**..... 3/4 npt(f) air exhaust port



10. If you are flushing, run the pump long enough to thoroughly clean the pump and hoses.
11. Close the dispensing valve, if used.
12. Close the bleed-type master air valve.
13. *Pumps with runaway protection:* Disable the prime/flush function by pushing the prime/flush button on the DataTrak.

Pump Shutdown



At the end of the work shift and before you check, adjust, clean or repair the system, follow **Pressure Relief Procedure**

Maintenance

Maintenance Schedule

Establish a preventive maintenance schedule, based on the pump's service history. Scheduled maintenance is especially important to prevent spills or leakage due to diaphragm failure.

Lubrication

The pump is lubricated at the factory. It is designed to require no further lubrication for the life of the pump.

Flushing and Storage



- Flush before fluid can dry in the equipment, at the end of the day, before storing, and before repairing equipment.
- Flush at the lowest pressure possible. Check connectors for leaks and tighten as necessary.
- Flush with a fluid that is compatible with the fluid being dispensed and the equipment wetted parts.

Flush the pump often enough to prevent the fluid you are pumping from drying or freezing in the pump and damaging it. Use a compatible solvent.

Always flush the pump and relieve the pressure before storing it for any length of time.



Operation

Pressure Relief Procedure



Trapped air can cause the pump to cycle unexpectedly, which could result in serious injury from splashing.

1. Shut off the air supply to the pump.
2. Open the dispensing valve, if used.
3. Open the fluid drain valve to relieve fluid pressure. Have a container ready to catch the drainage.

Flush the Pump Before First Use

The pump was tested in water. If water could contaminate the fluid you are pumping, flush the pump thoroughly with a compatible solvent.

Tighten Fasteners Before Setup

Before using the pump for the first time, check and retorque all external fasteners. After the first day of operation, retorque the fasteners.

Starting and Adjusting the Pump

1. Be sure the pump is properly grounded. Refer to **Grounding**
2. Check fittings to be sure they are tight. Use a compatible liquid thread sealant on male threads. Tighten fluid inlet and outlet fittings securely.
3. Place the suction tube (if used) in fluid to be pumped.

NOTE: If fluid inlet pressure to the pump is more than 25% of outlet working pressure, the ball check valves will not close fast enough, resulting in inefficient pump operation.

4. Place the end of the fluid hose into an appropriate container.
5. Close the fluid drain valve.
6. Back out the air regulator knob, and open all bleed-type master air valves.
7. If the fluid hose has a dispensing device, hold it open.
8. *Pumps with runaway protection:* Enable the prime/flush function by pushing the prime/flush button on the DataTrak.
9. Slowly increase air pressure with the air regulator until the pump starts to cycle. Allow the pump to cycle slowly until all air is pushed out of the lines and the pump is primed.



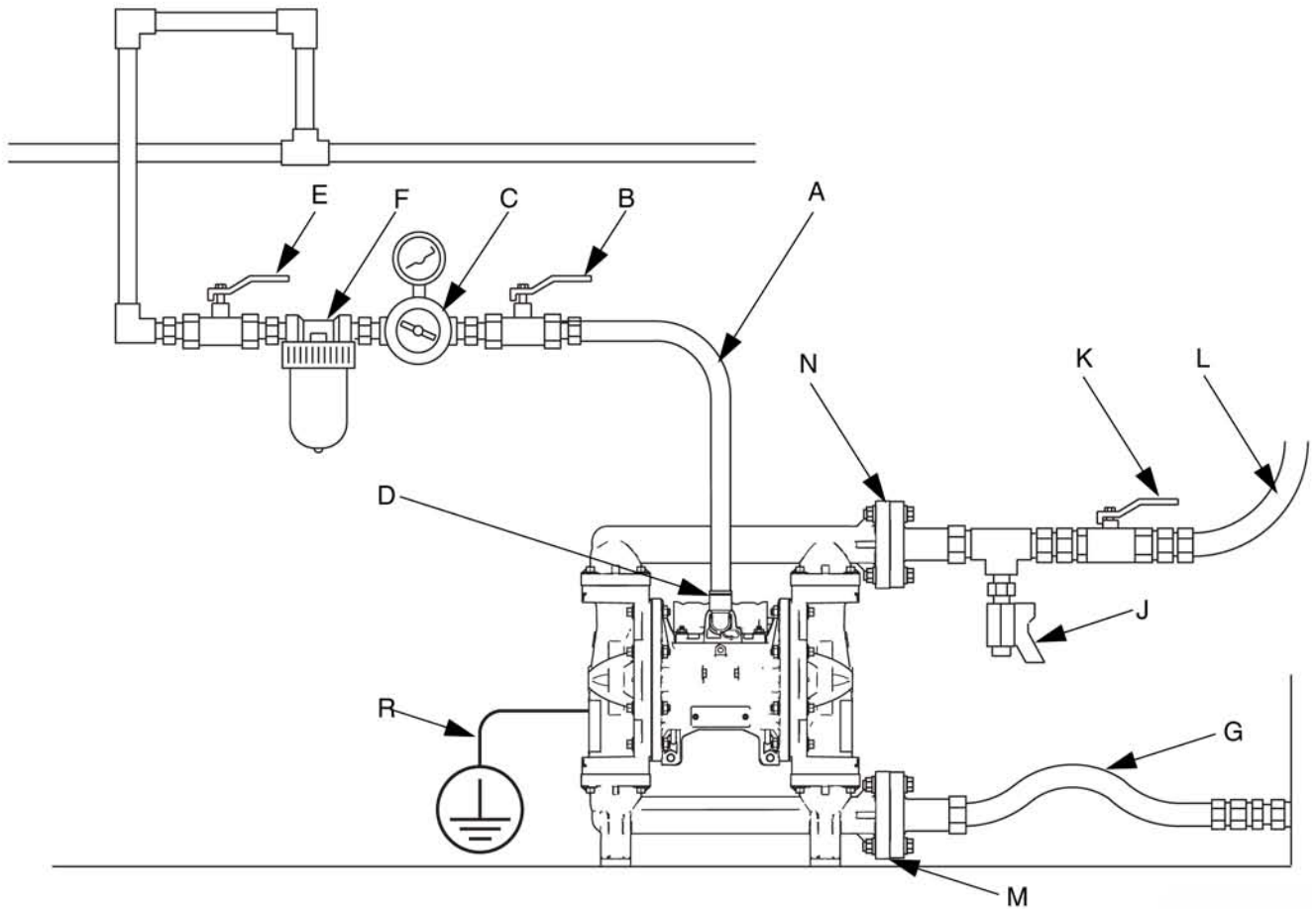

FIG. 4. Typical floor-mount installation (polypropylene, 1050P, pump shown)

Key for FIG. 3 and FIG. 4:

- A Air supply line
- B Bleed-type master air valve (required for pump)
- C Air regulator
- D Air inlet
- E Master air valve (for accessories)
- F Air line filter
- G Fluid suction line
- H Bung adapter
- J Fluid drain valve (required)
- K Fluid shutoff valve
- L Fluid line
- M Fluid inlet (Aluminum, FIG. 3, four ports, one not visible; Plastic, FIG. 4, center or end flanges available; Stainless Steel, not pictured, one port)

- N Fluid outlet (Aluminum, FIG. 3, four ports, one not visible; Plastic, FIG. 4, center or end flanges available; Stainless Steel, not pictured, one port)
- R Ground wire (required for aluminum, conductive polypropylene, and stainless steel pumps; see page 7 for installation instructions)



Parts

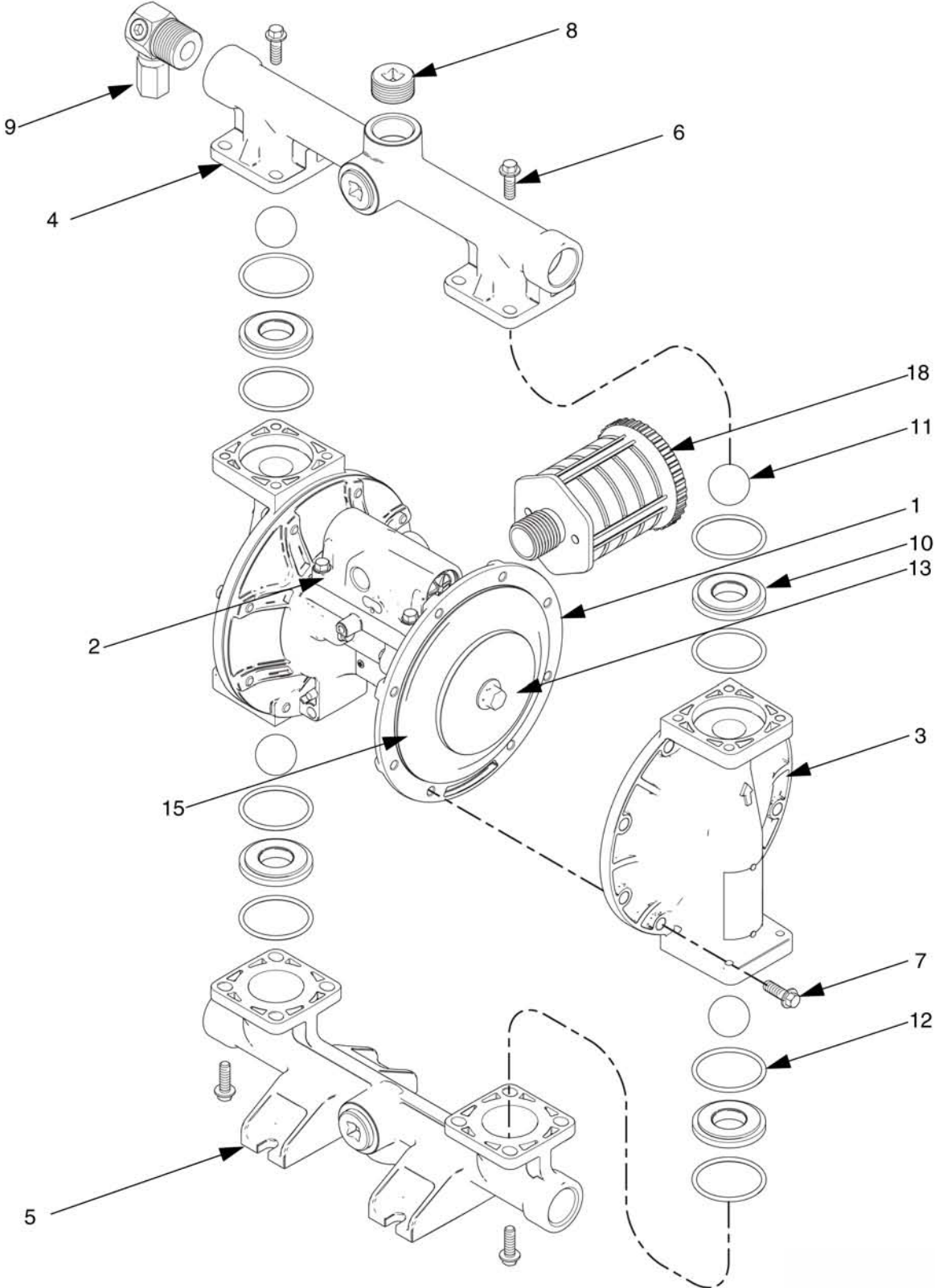

Parts/Kits Quick Reference

Use this table as a quick reference for parts/kits. See pages indicated in table for full description of kit contents.

Ref.	Part/Kit	Description	Qty.
1	Varies	Center Section; not sold separately Aluminum Polypropylene	1
2	Varies	Air Valve	1
3	24B653 24C051 24C050 24C061	Fluid Cover Kits Aluminum Conductive Polypropylene Polypropylene Stainless Steel	2
4	24B649 24B650 24C039 24C042 24C038 24C041 24C057 24C058	Outlet Manifold Kits Aluminum, npt Aluminum, bspt Conductive Poly, center flange Conductive Poly, end flange Polypropylene, center flange Polypropylene, end flange Stainless Steel, npt Stainless Steel, bspt	1
5	24B651 24B652 24C045 24C048 24C044 24C047 24C059 24C060	Inlet Manifold Kits Aluminum, npt Aluminum, bspt Conductive Poly, center flange Conductive Poly, end flange Polypropylene, center flange Polypropylene, end flange Stainless Steel, npt Stainless Steel, bspt	1
6	24B654 24C056 24C056 24C064	Manifold Fasteners; 8-pack Aluminum Conductive Polypropylene Polypropylene Stainless Steel	16
7	24B654 24C055 24C055 24C063 24C056	Fluid Cover Fasteners; 8-pack Aluminum Conductive Polypropylene Polypropylene Stainless Steel, aluminum center Stainless Steel, plastic center	16
8	24C617	Plug; 6-pack, aluminum pumps only	6
9	24B910	Pressure Relief Valve; fuel dispense model only	1

Ref.	Part/Kit	Description	Qty.
10	24B630 24B631 24B632 24B638 24B633 24B635 24B636 24B637 24B634	Seats; 4-pack, includes 8 o-rings where needed Acetal Aluminum Buna-N FKM Fluoroelastomer Geolast Polypropylene Santoprene Stainless Steel TPE	4
11	24B639 24B640 24B643 24B644 24B648 24B641 24B645 24B646 24B647 24B642	Check Balls; 4-pack, includes 8 o-rings Acetal Buna-N Neoprene Neoprene with SST core FKM Fluoroelastomer Geolast PTFE Santoprene Stainless Steel TPE	4
12	24B655	Manifold O-Ring; ptf, 8-pack,	8
13	24C035 24C036 24C036 24C062	Fluid Side Diaphragm Plate; included in Air and Fluid Plate Kits Aluminum Conductive Polypropylene Polypropylene Stainless Steel	2
14	----	Air Side Diaphragm Plate (not visible); included in Air and Fluid Plate Kits	2
15	24B622 24B629 24B623 24B628 24B624 24B625 24B626 24B627	Diaphragm Kits Buna-N Standard FKM Fluoroelastomer Standard Geolast Standard Santoprene Standard TPE Standard Neoprene Overmolded PTFE Overmolded PTFE/EPDM Two-Piece	2
18	112182	Muffler; 3/4 npt, plastic	1
19	116343 116344	Screw, ground, M5 x 0.8; not shown Aluminum pumps, carbon steel Conductive Poly Pumps, stainless steel	1
20▲	188621	Label, warning (not shown)	1

▲Replacement Warning labels, signs, tags, and cards





Parts List For

Calcium Chloride Pump

Model 10543

Calcium Chloride Pump

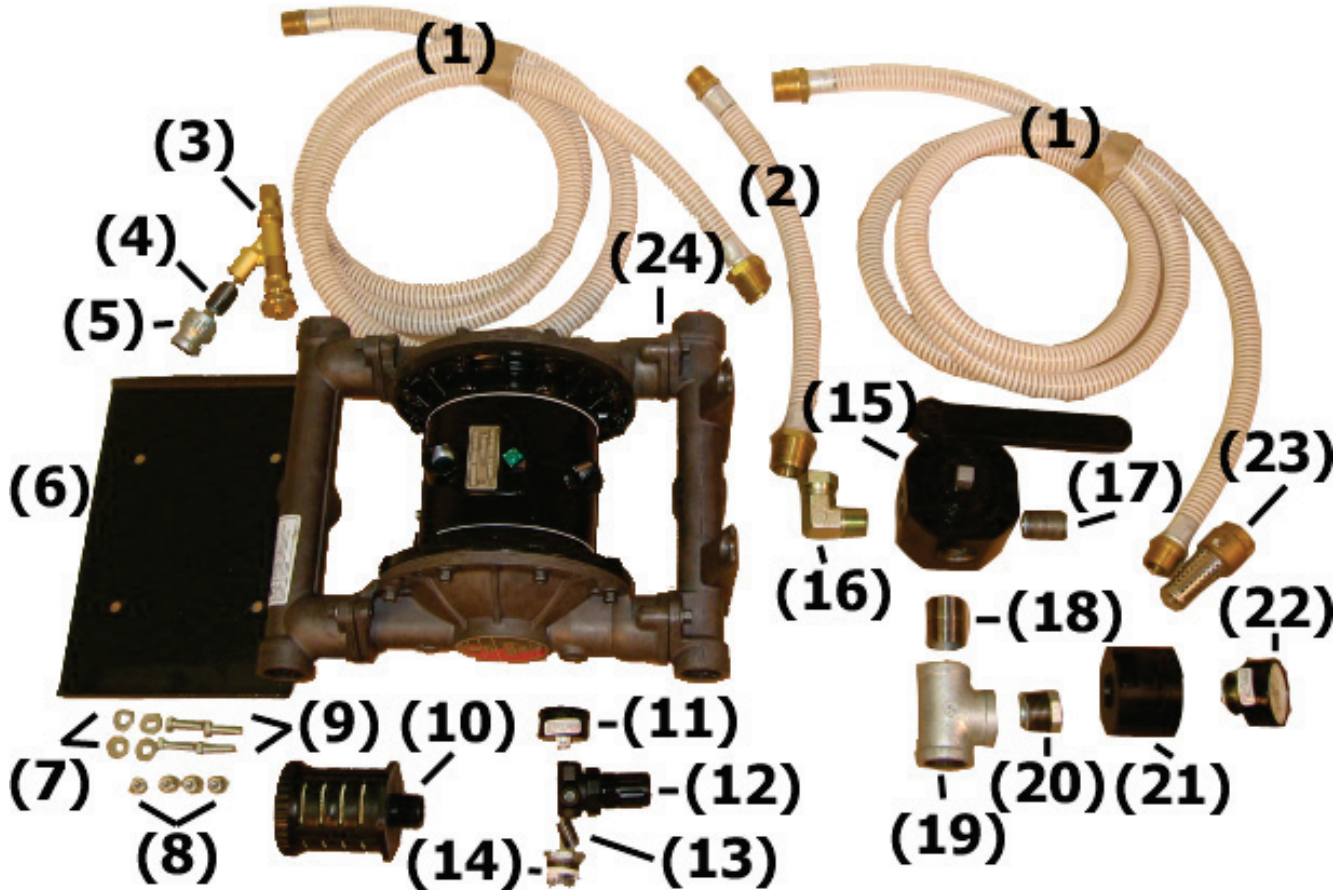

ITEM NO.	PART NO.	NO. REQ'D	DESCRIPTION	ITEM NO.	PART NO.	NO. REQ'D	DESCRIPTION
1	10537	2	Calcium Hose 10" x 3/4" x 1"	13	10565	1	Nipple, 1/2" Close
2	10531	1	Calcium Hose 17" OAL x 3/4" x 1"	14	10569	1	Bushing, 1/2" x 1/4"
3	10522	1	Calcium Ejector Gun	15	10513	1	4 Way Valve w/ Handle, Poly
4	10570	1	Nipple, 1/2" Close	16	10536	1	Fitting, Brass w/ Swivel
5	10571	1	Reducer, 3/4" x 1/2"	17	10567	1	Nipple, 3/4" Close
6	10561	1	Plate, Base	18	10579	1	Nipple, 1" Close
7	10575	4	Washer, 1/4"	19	10564	1	Tee, 1"
8	10573	4	Nut, 1/4 - 20	20	10568	1	Bushing, 1" x 1/4"
9	10574	4	Cap Screw, 1/4" x 3 1/2"	21	SB-GP	1	Gauge Protector
10	10554	1	Muffler	22	10521	1	1/4" Vacuum Pressure Gauge
11	10520	1	1/8" Air Gauge	23	10535	1	Suction Strainer
12	10523	1	Regulator	24	10509P	1	Pump



Hydro Inflation Chart

NOTES:

1. Tables are based on using type 1 calcium chloride (75% CaCl₂). If type 2 concentrated calcium chloride (90% CaCl₂) is used, reduce specified "Lbs. CaCl₂" in tables by 25%.
2. Values shown in tables are approximate and represent 75% fill or "valve level" fill (valve valve at top of tire) which is recommended practice.
3. Antifreeze protection levels are shown at top of each table for different solutions.
4. For non tires mounted on narrower rims, decrease quantities at the rate of 4% for each 1-inch reduction in rim width. For wider tires, increase quantities by 4% for each 1-inch increase in rim width.

Tire Size	Rim Width	WATER			3 1/2 LB. SOLUTION			5 LB. SOLUTION				
		Water Gal	Weight Lbs	CaCl ₂ Lbs	Slush-free to -12°F. Solid at -52°F.	Water Gal	CaCl ₂ Lbs	Total Wt.	Slush-free to -12°F. Solid at -52°F.	Water Gal	CaCl ₂ Lbs	Total Wt.
DRIVE WHEEL TIRES												
8.3-20	7.00	10	82	8	38	100	8	40	107			
8.3-22	7.00	9	76	7	35	92	7	37	98			
8.3-24	7.00	13	108	11	39	131	10	50	133			
9.5-16	8.00	12	100	10	35	118	10	50	133			
9.5-18	8.00	12	99	9	45	121	10	48	128			
9.5-20	8.00	13	110	10	50	134	11	54	143			
9.5-22	8.00	15	123	11	56	150	12	60	159			
9.5-24	8.00	17	142	15	53	178	14	70	187			
9.5-32	8.00	22	183	19	67	225	18	90	240			
9.5-36	8.00	25	208	22	77	260	20	100	267			
9.5-42	8.00	29	242	25	88	296	23	115	307			
11.2-24	10.00	24	200	20	70	237	19	95	253			
11.2-28	10.00	27	225	24	84	284	22	110	293			
11.2-36	10.00	35	292	30	105	355	28	140	374			
12.4-24	10.00	36	300	31	109	368	29	145	387			
12.4-28	11.00	30	250	26	91	308	25	125	333			
12.4-38	11.00	35	292	30	105	355	28	140	374			
12.4-48	11.00	44	367	38	133	450	36	180	480			
12.4-56	11.00	46	384	40	140	474	37	185	494			
12.4-62	11.00	51	425	44	154	521	41	205	547			
12.4-66	12.00	53	442	45	158	533	43	215	573			
12.4-54	10.00	58	484	49	172	581	47	235	627			
12.4-54	10.00	58	484	49	172	581	47	235	627			
13.6-24	12.00	38	317	32	112	379	30	150	400			
13.6-26	12.00	40	334	35	123	415	33	165	440			
13.6-28	12.00	43	359	37	130	439	35	175	467			
13.6-36	12.00	50	420	38	152	511	41	204	543			

Tire Size	Rim Width	WATER			3 1/2 LB. SOLUTION			5 LB. SOLUTION				
		Water Gal	Weight Lbs	CaCl ₂ Lbs	Slush-free to -12°F. Solid at -52°F.	Water Gal	CaCl ₂ Lbs	Total Wt.	Slush-free to -12°F. Solid at -52°F.	Water Gal	CaCl ₂ Lbs	Total Wt.
DRIVE WHEEL TIRES												
13.6-38	12.00	57	475	49	172	581	46	230	614			
13.6R38	12.00	65	542	55	193	651	52	260	694			
212/80D15	7.00	8	69	6	31	84	7	33	89			
31S/75D15	10.00	20	164	15	75	200	16	80	212			
35S/80D20	11.00	25	288	26	132	351	28	140	373			
47S/64D20	15.00	52	432	39	197	525	42	209	559			
13.0-36	12.00	51	425	44	154	521	42	210	560			
14.0-24	13.00	47	392	40	140	474	38	190	507			
14.0-26	12.00	48	400	41	144	486	39	195	520			
14.0R26	12.00	48	400	41	144	486	39	195	520			
14.0-28	13.00	53	442	46	161	545	43	215	574			
14.0R28	13.00	57	475	48	168	568	46	230	614			
14.0-30	13.00	63	525	54	189	639	51	255	680			
14.0R30	13.00	67	559	58	203	687	55	275	734			
14.0-38	12.00	67	559	58	203	687	55	275	734			
14.0-46	12.00	80	667	68	238	805	65	325	867			
14.0R46	14.00	66	550	56	196	663	53	265	707			
15.5-38	15.00	61	509	52	182	616	49	245	654			
16.0R24	15.00	61	509	52	182	616	49	245	654			
16.0-26	15.00	65	542	56	196	663	52	260	694			
16.0R26	15.00	65	542	56	196	663	52	260	694			
16.0-28	15.00	69	575	59	207	699	56	280	747			
16.0R28	15.00	73	609	63	221	746	59	295	787			
16.0-30	15.00	82	684	70	245	829	66	330	880			
16.0R30	15.00	90	751	77	270	912	73	365	974			
17.5L-24	15.00	55	459	47	165	557	45	225	600			
18.4-16.1	16.00	49	409	42	147	497	39	195	520			

Operating Temperature Range

NOTICE

Temperature limits are based on mechanical stress only. Certain chemicals will further limit the maximum operating temperature range. Stay within the temperature range of the most-restricted wetted component. Operating at a temperature that is too high or too low for the components of your pump may cause equipment damage.

Diaphragm/Ball/Seat Material	Operating Temperature Range			
	Aluminum or Stainless Steel Pumps		Polypropylene or Conductive Polypropylene Pumps	
	Fahrenheit	Celsius	Fahrenheit	Celsius
Acetal (AC)	10° to 180°F	-12° to 82°C	32° to 180°F	0° to 82°C
Buna-N (BN)	10° to 180°F	-12° to 82°C	32° to 180°F	0° to 82°C
FKM Fluoroelastomer (FK)*	-40° to 275°F	-40° to 135°C	32° to 180°F	0° to 82°C
Geolast® (GE)	-40° to 150°F	-40° to 66°C	32° to 150°F	0° to 66°C
Neoprene overmolded diaphragm (CO) or Neoprene check balls (CR or CW)	0° to 180°F	-18° to 82°C	32° to 180°F	0° to 82°C
Polypropylene (PP)	32° to 180°F	0° to 82°C	32° to 180°F	0° to 82°C
PTFE overmolded diaphragm (PO)	40° to 180°F	4.0° to 82°C	40° to 180°F	4° to 82°C
PTFE check balls or two-piece PTFE/EPDM diaphragm (PT)	40° to 220°F	4° to 104°C	40° to 180°F	4° to 82°C
PVDF (PV)	10° to 225°F	-12° to 107°C	32° to 180°F	0° to 82°C
Santoprene® (SP)	-40° to 180°F	-40° to 82°C	32° to 180°F	0° to 82°C
TPE (TP)	-20° to 150°F	-29° to 66°C	32° to 150°F	0° to 66°C

* The maximum temperature listed is based on the ATEX standard for T4 temperature classification. If you are operating in a non-explosive environment, FKM fluoroelastomer's maximum operating temperature in aluminum or stainless steel pumps is 320°F (160°C).



Technical Data

Maximum fluid working pressure	125 psi (0.86 MPa, 8.6 bar)
Air pressure operating range	20-125 psi (0.14-0.86 MPa, 1.4-8.6 bar)
Maximum air consumption	67 scfm
Air consumption at 70 psi (0.48 MPa, 4.8 bar), 20 gpm (76 lpm)	25 scfm
Maximum free-flow delivery	50 gpm (189 lpm)
Maximum pump speed	280 cpm
Fluid displacement per cycle	0.17 gal. (0.64 liters)
Maximum suction lift	16 ft (4.9 m) dry, 29 ft (8.8 m) wet
Maximum size pumpable solids	1/8 in. (3.2 mm)
Sound Power*	
at 70 psi (0.48 MPa, 4.8 bar) and 50 cpm	78 dBa
at 100 psi (0.7 MPa, 7.0 bar) and full flow	90 dBa
Sound Pressure**	
at 70 psi (0.48 MPa, 4.8 bar) and 50 cpm	84 dBa
at 100 psi (0.7 MPa, 7.0 bar) and full flow	96 dBa
Operating temperature range	see page 23
Air inlet size	1/2 npt(f)
Fluid inlet size	
Aluminum (1050A)	1 in. npt(f) or 1 in. bspt
Fluid outlet size	
Aluminum (1050A)	1 in. npt(f) or 1 in. bspt
Weight	
Aluminum (1050A)	23 lb. (10.5 kg)
Wetted parts	
Aluminum (1050A)	aluminum and material(s) chosen for seat, ball, and diaphragm options
Non-wetted external parts	
Aluminum (1050A)	aluminum, coated carbon steel

* Sound power measured per ISO-9614-2.

** Sound pressure was tested 3.28 ft (1 m) from equipment.

All trademarks mentioned in this manual are the property of their respective owners.

