



Repair Parts Sheet

Tire Bead Breaker Model 10105

*NOTE – Identifying feature 5 digit number cast on Frame Item #10.

BEAD BREAKER

Max. Capacity: 11.2 Ton At 10,000 PSI

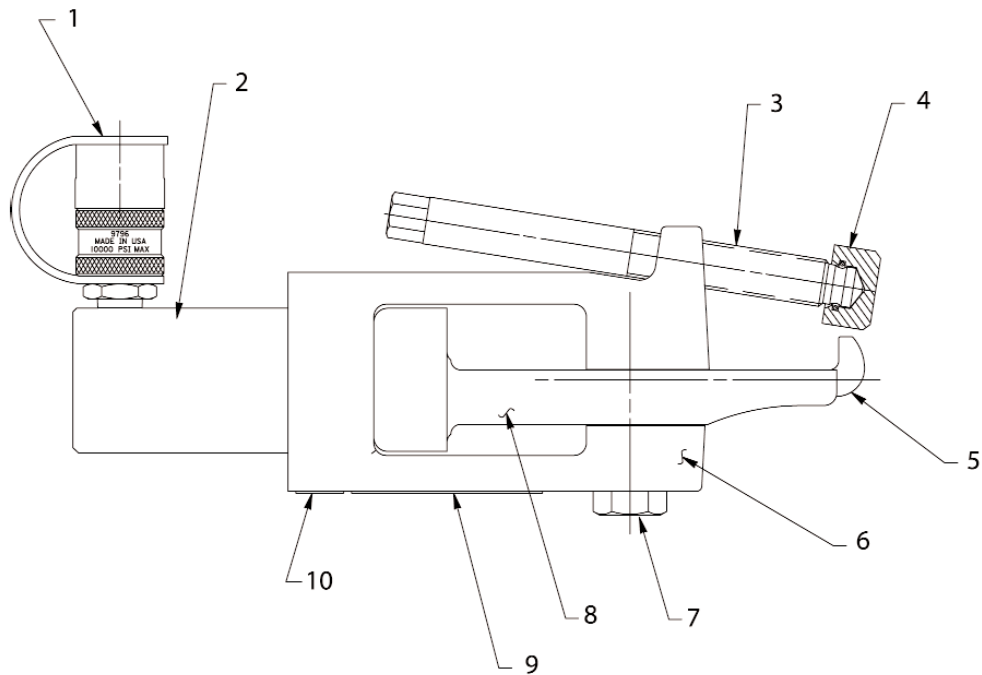

ITEM NO.	PART NO.	NO. REQ'D	DESCRIPTION
1	10606	1	Ram Half Coupler with Dust Cap
2	422155	1	Replacement Cylinder (see page 2)
3	34184	4	Screw, Hex Hd (3/4-10 x 7-9/16)
4	28705	1	Foot
5	36958	1	Hook
6	41084YE3	1	Frame, Machining
7	22469	1	Screw Shoulder (5/8-11 x 2-1/4)
8	58369YE3	1	Clevis
9	208106	1	Decal, Warning
10	260095	1	Decal, Warning



Model 10105 BEAD BREAKER

Max. Capacity: 11.2 Ton At 10,000 PSI

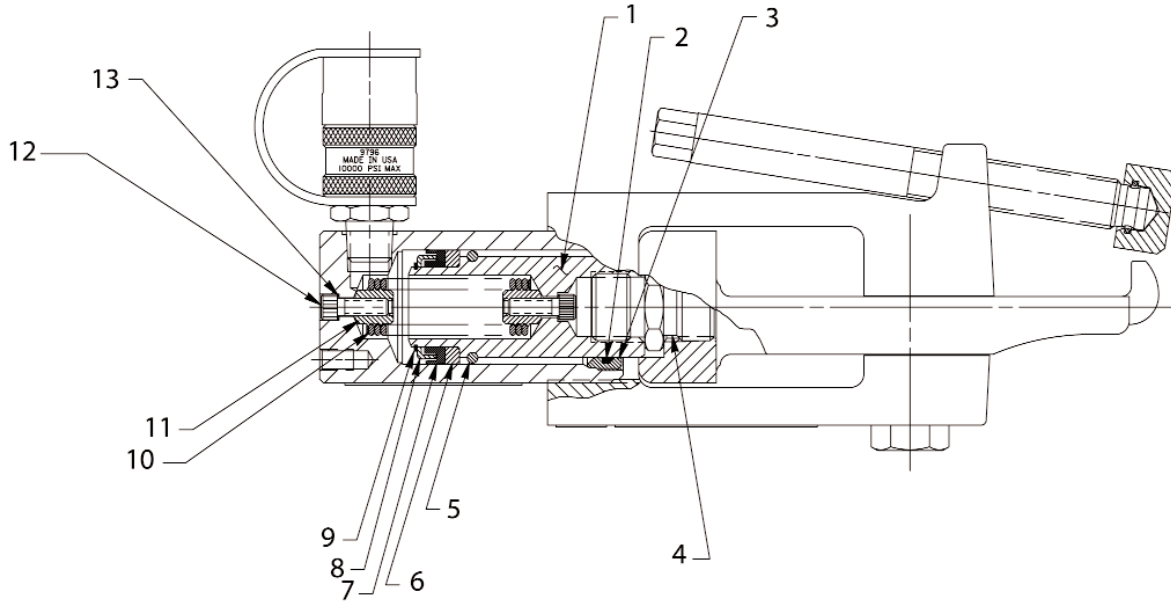

ITEM NO.	PART NO.	NO. REQ'D	DESCRIPTION
1	421115	1	Rod, Piston
2	201429	1	Wiper, Rod
3	351030	1	Nut, Retainer
4	251146	1	Adapter, Threaded
5	201433	1	Ring, Retain Int
6	201363	1	Head, Piston
7	16067	1	U Cup
8	201359	1	Retainer, Clip
9	16076	1	Ring, Retainer (External)
10	201430	1	Spring (.83 OD x 1.90 x .13 WS)
11	201360	2	Retainer, Spring
12	10008	2	Soc. Hd. Cap Screw (1/4-20 x 3/4)
13	10442	2	Washer, Copper (.37 x .25)

Refer to Operating Instructions included with this product for detailed information about operation, testing, disassembly, reassembly, and preventive maintenance.

Items found in this parts list have been carefully tested and selected.





Repair Parts Sheet

10105 (OTR-1600) BEAD BREAKER For Date Codes Beginning With The Letter "O"

*NOTE – Identifying feature DA number on frame Item #14

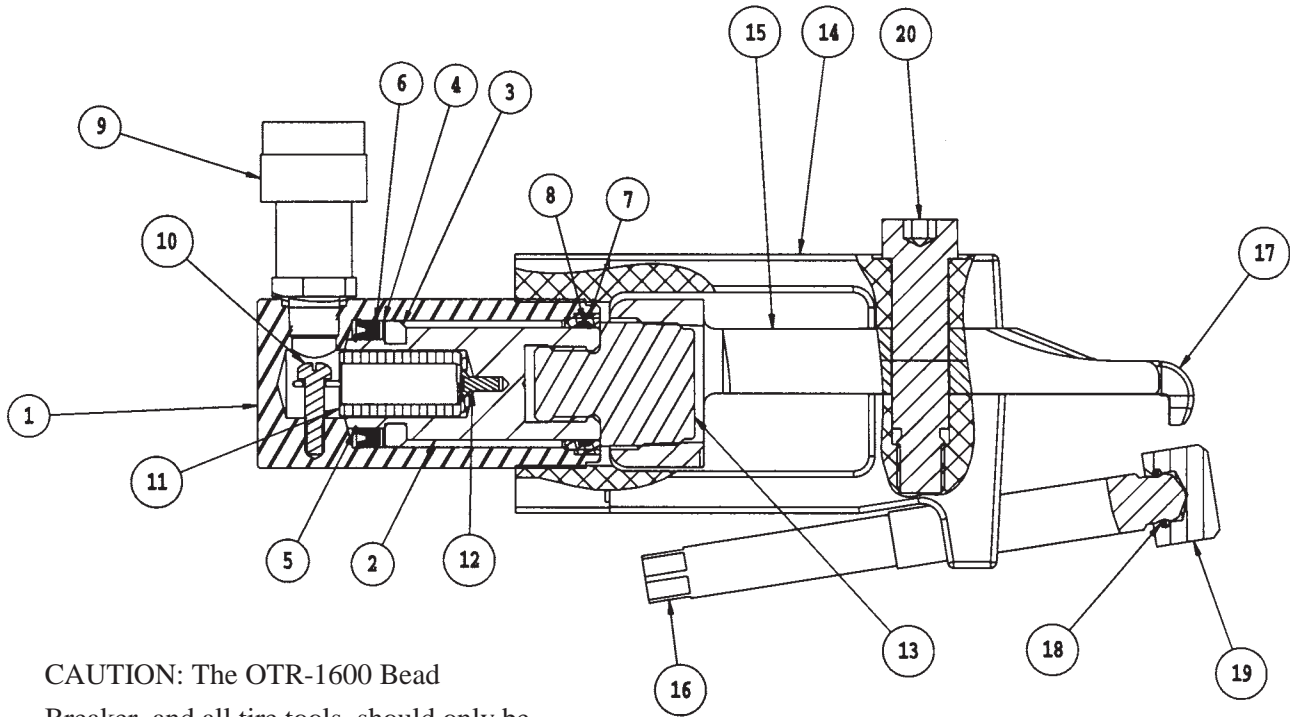

CAUTION: The OTR-1600 Bead Breaker, and all tire tools, should only be used by persons properly trained according to OSHA regulation #29CFR1910.177, "Servicing Single-

ITEM	PART NUMBER	QTY.	DESCRIPTION	ITEM	PART NUMBER	QTY.	DESCRIPTION
1	G469005	1	Base (not serviced)	11	L202110	1	Spring
2	DA2283040	1	Plunger	12	DA2286028	1	Screw
3	G382107	1	Bearing	13	202179	1	Adapter
4	*G384108	1	Washer	14	U972078-001	1	Frame
5	*C611049	1	Retainer Ring	15	U972078-056	1	Clevis
6	*CB6630341	1	U-Cup	16	34184	1	Set Screw
7	G385044	1	Stop Ring	17	36958	1	Hook
8	*G416044	1	Wiper	18	DA11816-049	1	Retainer Ring
9	10606	1	Coupler	19	28705	1	Pressure Nut
10	*G836028	1	Screw	20	22469	1	Screw

Note A: Item #1, base, is not a serviceable item. Order ESCO replacement cylinder ESC-104.

* Indicates items included in, and available only as part Repair Kit RC102K.





Operating Instructions for:

10100
10105
Tire Bead Breakers

IMPORTANT RECEIVING INFORMATION

Visually inspect all parts for shipping damage. If you find shipping damage, notify the carrier at once. Shipping damage is not covered by your warranty. The carrier is responsible for all costs of replacement or repair caused by shipping damage.

CONTENTS

ENGLISH.....	1-6	FRANÇAIS	13-18	ITALIANO	25-30
DEUTSCH	7-12	ESPAÑOL	19-24	NEDERLANDS	31-36

DESCRIPTION

These bead breakers are used on 25"-51" multi-piece rims with pry bar pockets. They are designed to break earthmover tire beads on any rim. They can be used with models 10590, 10592, 10594, or equivalent 10,000 psi [700 bar] pumps.

Model No.	10100	10105
Stroke [in. (cm)]	4.25 (10,8)	2.13 (5,4)
Capacity [U.S. Tons]	14	11

SAFETY INFORMATION

To avoid personal injury or property damage while using this product, read and follow all **DANGERS, WARNINGS, CAUTIONS, and INSTRUCTIONS** that are attached to, or included with, this product.

1. Follow the instructions of the tire manufacturer and the vehicle manufacturer when deflating, demounting, mounting, and inflating tires.
2. These operating instructions do not apply to any specific rim. Therefore, contact the rim manufacturer for the correct procedure for your rim.
3. For the publication, "Multipiece Rim Matching Chart" contact the United States Department of Labor, Occupational Safety, and Health Administration (OSHA), Washington, DC, 20210, 202-219-6091 or contact ESCO at 1-800-352-9852. If you are outside the U.S., contact your local government officials.
4. ESCO cannot be held responsible for damage or injury resulting from unsafe use of this product, lack of maintenance, or incorrect product and system application.
5. Contact ESCO when in doubt about safety precautions or applications.

▲ WARNING

To avoid serious personal injury, always wear proper protective gear, such as hard hats, safety glasses, gloves, and steel toe shoes when using hydraulic equipment.

▲ CAUTION

The bead breaker, and all tire tools, should be used only by persons properly trained according to OSHA Regulation #29CFR1910.177, "Servicing Single-Piece & Multi-Piece Wheels." Free copies of this regulation are available upon request from ESCO.

OPERATING INSTRUCTIONS

REMOVING THE WHEEL

1. Chock the wheels opposite the jack.
2. Jack up the vehicle.
3. Crib the vehicle with safety stands or blocking devices after jacking it up. Do not work under an unblocked load.

▲ DANGER

Failure to chock the wheels and crib the vehicle can result in serious injury or death.

4. Remove the valve core; deflate tires completely. (See Fig. 1.)
5. Insert a thin piece of wire through the valve stem to make sure air is flowing freely and the valve stem is not blocked.

NOTE: Deflate both tires if you have a dual mounting.

▲ DANGER

Always deflate tires before removing a wheel, a rim, or part of a rim, such as a rim clamp or nut. If you do not deflate the tire, the tire could explode, causing serious injury or death.

- 6a. If you are breaking the tire bead with the wheel on the vehicle: Proceed to Step 1 below, "Positioning the Bead Breaker."
- 6b. If you are breaking the tire bead with the wheel off the vehicle: Remove the tire/rim assembly from the vehicle and place it flat on the ground with the gutter side up. Then proceed to Step 1 below, "Positioning the Bead Breaker."

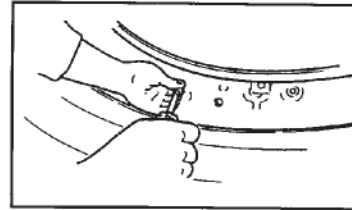

Figure 1

USING THE OTR-1825D or OTR-1600 BEAD BREAKERS

Positioning the Bead Breaker

1. Place the bead breaker into the continuous pry bar pocket, with the hooks under the lip of the bead seat band. (See Fig. 2.)
2. Position the bead breaker so that it is about 30°, or at least 12 inches [0,3 m], to one side of the flange butt weld.
3. Adjust the ram adjusting screw so that the bead breaker is perpendicular (90°) to the wheel. (See Fig. 2.)
4. Stand to one side of the bead breaker. Hold the bead breaker with one hand. (See Fig. 3)

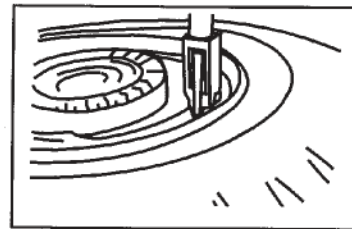

Figure 2

▲ DANGER

Always stand to one side of the rim when using the bead breaker. Standing to one side of the bead breaker allows you to maintain control of the bead breaker. If it is not seated properly and flies off the rim, the bead breaker could cause serious injury or death.

Activating the Bead Breaker

▲ CAUTION

The bead breaker uses a long stroke and high force. Be careful not to damage or bend rim parts, such as the flange butt weld, when using the bead breaker.

1. Turn on the hydraulic pump to activate the bead breaker.
2. Apply enough hydraulic pressure to the bead breaker to push the flange about 1/2-3/4 inch [13-19 mm] from the lip of the bead seat band.

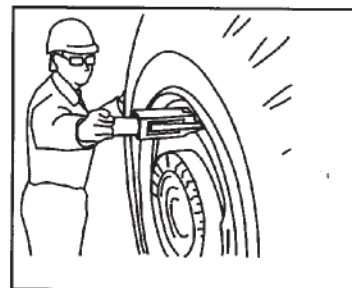

Figure 3

3. If the bead breaker moves and is no longer vertical, readjust the ram adjusting screw. You must release pressure before adjusting the screw.
4. Continue applying hydraulic pressure until the flange is about 3/4 - 1 inch [19-25 mm] from the lip of the bead seat band.
5. Place a nut or similar object between the flange and the lip of the bead seat band. (See Figure 4)

⚠ WARNING

To prevent personal injury, lay the nut on the flange and slide it into position with two screwdrivers. Do not put your fingers under the bead seat band.

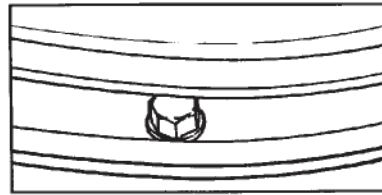

Figure 4

6. Release hydraulic pressure.

Continuing to Break the Tire Bead

1. Move the bead breaker away from the flange butt weld, 2-3 feet [0,5-1,0 m] from its present position.
2. Follow the steps in “Activating the Bead Breaker” above.
3. Continue advancing the bead breaker around the rim, 2-3 feet [0,5-1,0 m] at a time, breaking the tire bead.
4. Stop breaking the tire bead when you have moved the bead breaker about 3/4 of the way around the rim. (See Fig. 5.)

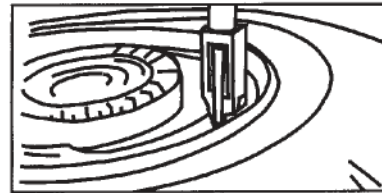

Figure 5

⚠ CAUTION

To prevent damage to the rim, do not use the bead breaker within 12 inches of the flange butt weld.

5. Apply enough pressure to the bead breaker to completely break the tire bead.
6. Release the hydraulic pressure.

NOTE: If you have gone all the way around the tire and the tire bead does not break: Repeat the steps in “Activating the Bead Breaker” and “Continuing to Break the Tire Bead” above, with more hydraulic pressure.

Removing the Lock Ring and O-Ring

1. Remove the lock ring with two pry bars. Start at the split in the ring and then work the tools around the ring (See Fig. 6.)
2. Place a pry bar or screwdriver under the o-ring and pull it out from the groove in the rim. Cut the o-ring with a knife to ensure that a new o-ring is used. (See Fig. 7.)

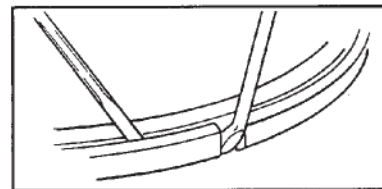

Figure 6

Removing the Bead Seat Band

1. Carefully lift the bead seat band off the rim. Use pry bars and the ESCO Flange Ring Puller Model 90300.
2. Carefully remove the flange from this side of the tire

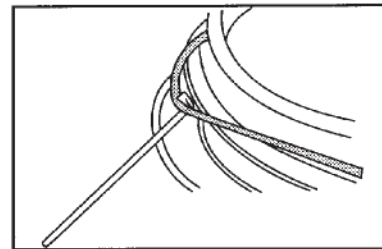

Figure 7

Breaking the Bead on the Other Side

1. When the wheel is on the vehicle, use the bead breaker to break the back tire bead, following the same procedure used on the front tire bead. If the wheel is on the vehicle, you may need to use a smaller ram, such as an ESCO ESC-30 (10306), between the frame of the vehicle and the back flange (See Figure 8). Repeat the steps in “USING THE OTR-1825D OR OTR-1600 BEAD BREAKERS” on pages 2 and 3.

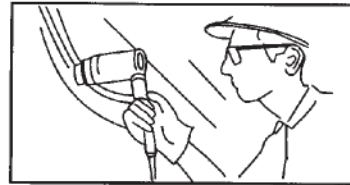

Figure 8

2. If the tire is still on the vehicle: Remove the tire using a boom truck and tire sling (ESCO Model 90100). Remove the back flange to complete the disassembly.
3. Remove the rear rim flange from the rim.

MOUNTING AND INFLATION

Jacking Up the Vehicle

1. Chock the wheels opposite the jack.
2. Jack up the vehicle.
3. Crib the vehicle with safety stands or blocking devices after jacking it up. Do not work under an unblocked load.

▲ DANGER

Failure to chock the wheels and crib the vehicle can result in serious injury or death.

Inspecting the Tire and Rim

▲ DANGER

Always replace damaged or badly worn tires. When replacing tires, always use a replacement of exactly the same diameter. Destroy old tires, so that they cannot be used. Using badly worn or damaged tires can result in serious injury or death.

1. Inspect all rim parts for damage.

▲ DANGER

Always replace rim parts that are bent, badly rusted, pitted from corrosion, cracked, worn, or damaged. Destroy old rim parts, so they cannot be used. Using damaged rim parts can result in serious injury or death.

Do not mix parts from one rim with parts from another rim. Always use replacement parts that you can positively identify as the CORRECT replacement parts. All replacement rim parts MUST match the replacement part numbers stamped on the rim parts. Rims with different part numbers cannot be interchanged. If in doubt about sizing, DO NOT reassemble the rim. Contact the rim manufacturer for more information.

2. Replace damaged parts.

▲ DANGER

Never weld on an inflated or partially inflated tire/rim assembly. Welding on an inflated tire/rim assembly can cause an explosion and serious injury or death.

Do not rework, weld, heat, or braze any rim parts for any reason. Reworking and welding damaged parts can result in serious injury or death.

3. Clean and repaint rim parts as necessary.

NOTE: Remove rust, dirt, and foreign material from rim parts. Repainting the rim parts and bare metal areas will make them last longer. Be careful to keep paint out of the lock ring groove in the gutter when repainting rim parts.

4. Visually inspect all tire and rim parts to make sure they are positioned properly.

Starting to Inflate the Tire

1. To comply with OSHA Regulation #29CFR1910.177, place the tire in a safety cage or other restraining device, such as an ESCO Push Bar Model 90201, before inflating the tire. Use a clip-on air chuck and a hose that is long enough to allow you to stand outside the wheel trajectory. The air line must be equipped with an in-line valve with a pressure gauge or a regulator that can be preset. Use ESCO Truck Tire Inflator Model 15136.

⚠ DANGER

Always use a safety cage or restraining device, such as an ESCO Push Bar Model 90201, when inflating a tire. Not using a safety cage or restraining device can result in serious injury or death.

Always use a clip-on air chuck and a hose that is long enough to allow you to stand outside the wheel trajectory. The air line must be equipped with an in-line valve with a pressure gauge or a regulator that can be preset.

Never use starting fluid, ether, gasoline, or any other flammable material to lubricate, seal, or seat the bead of a tubeless tire. Doing so can cause an explosion and serious injury or death.

2. Inflate the tire to 5 psi [0,345 bar]
3. Check all tire and rim parts again for proper positioning. Make sure the o-ring does not slip out of its groove.
4. If tire/rim parts are not seated properly, deflate the tire and correct the problem before proceeding.

⚠ WARNING

Never hammer, strike, or pry an inflated or partly inflated tire/rim assembly. If you must seat a part or correct a problem, always deflate the tire first.

⚠ CAUTION

Do not use a steel hammer on rim or rim parts. This can damage the rim. If you must reposition tire or rim parts, use a rubber, plastic, or brass-faced hammer.

If a tire/rim assembly does not slide over a cast spoke wheel, do not force the assembly by hammering. Instead, deflate the tire and inspect for warped or incorrectly seated parts, such as lock rings.

5. If tire and rim parts are seated properly, proceed to “Finishing the Tire Inflation” below.

Finishing the Tire Inflation

1. Inflate the tire to 20 psi [1,38 bar]
2. Check the tire bead for proper seating.
3. Continue inflating the tire to 40 psi [2,76 bar]. If the tire bead is not fully seated, see the **Warning** below. If the tire bead is fully seated, continue with Step 4 below.

⚠ WARNING

Never inflate a tire beyond 40 psi [2,76 bar] to seat a tire bead. If the tire bead is not fully seated at 40 psi [2,76 bar]: Stop! Deflate the tire and correct the problem.

4. Once you see that the tire bead is fully seated at 40 psi [2,76 bar], deflate the tire completely.
5. Reinflate the tire slowly to the manufacturer’s recommended pressure.

⚠ DANGER

Inflate and load tires only to manufacturer’s specifications. Over-inflating and overloading tires can result in serious injury or death.

Never run a vehicle with only one tire of a dual assembly. Doing so can result in a collapse of the vehicle and lead to serious injury or death.