

SYNESSO S SERIES

OWNER'S MANUAL

VERSION 2020.1

Last Revision: September 2020



5610 4th Ave S. / Seattle, WA 98108—USA

Tel: +1 206 764 0600 / Fax: +1 206 764 0601

Ordering Parts: parts@Synesso.com

Technical Support: tech@Synesso.com

Information: info@Synesso.com

www.Synesso.com



TABLE OF CONTENTS

Introduction	3
Safety Warnings	4
Depressurizing Tanks, Tank Safety	5
Start Up Screen, Serial #, Software Ver.	6
List of Tools and Supplies	6
Warranty & Water Standards	7-8
Plumbing Requirements	9
Electrical Requirements	10
Installation and Installation Diagrams	11-13
Startup	14
Operation	15-17
Programming - Handheld Controller	18-29
Menu Level 1 - Operations	18-22
Volumetric Programs	20
Error Codes	22
Menu Level 2 - Settings	23-28
Program Mode / Temp. Scale	23
Error Log	28
Firmware	29
Maintenance	30-33
Quarterly Preventative Maintenance Guide	32
Annual Warranty Checklist	33
Flowmeter Calibration Instructions	34
Troubleshooting Guide	35-41

INTRODUCTION

Congratulations on the purchase of your Synesso espresso machine. Please read this Technical Manual and retain it in a safe location for future reference. If you have any questions about your machine, please contact Synesso and our knowledgeable staff will assist you

Factory Contract Information:

Synesso Inc.
5610 4th Ave South
Seattle, WA 98108 - USA
Tel: +1.206.764.0600 / Fax: +1.206.764.0601

E-mail: info@Synesso.com
Web: www.Synesso.com
Twitter: @SynessoFactory
Instagram: Synessofactory

Please WRITE your Serial Number & Offset Information here. This can be found on the 2nd & 3rd Menu Levels of the Display Controller. Have this available BEFORE calling for service or technical support.

S/N: _____

The offsets for this machine are:

BG1: _____ °F / BG2: _____ °F / BG3: _____ °F

Steam Tank: _____ °F

Included in the package with this machine you will find the following:

- Thumb Drive containing the Owner's Manual and other technical documents
- Pump/Motor Combination + hoses (3/8" compression fittings on all hoses)
- 8' Long metal reinforced 3/4" ID drain hose + hose clamp (attached)
- Fitting, 1/4" male NPT x 90° x 3/8" Compression (if not CE)
- Accessory Package: Portafilters (per customer specification), blind basket, Synesso 3 oz. (90ml) shot glass, 4oz jar cleaning detergent, and a 58.4mm tamper.
- Electrical plugs are ONLY included on CSA Certified machines (Canada). For all other machines, the owner of the machine must purchase an appropriate plug end for their machine. Please see the installation instructions starting on page 11 for more information.

Serial Number

Your espresso machine has a unique serial number, this number can be found on the serial number label located on the back side of the handheld display controller. The number can also be read on the display during start-up. Please have this serial number available for reference when contacting the factory.

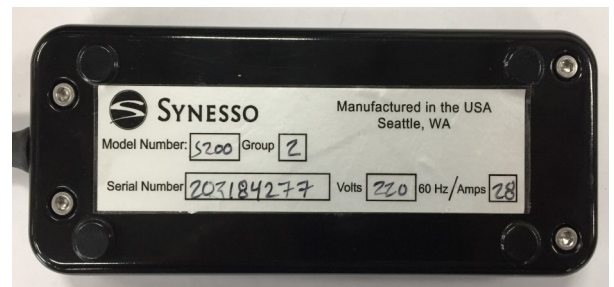

This manual applies to Synesso models S200 and S300. "S Series" machines are fully volumetric with up to 6 programmable dispensed volumes, depending on settings. The S series machines have an external pump and motor.

SAFETY WARNINGS

IMPORTANT Information for Synesso™ Espresso Machines: **DISCONNECT FROM POWER BEFORE SERVICING.**

- Read the entire manual before operating this machine.
- Steam and condensation from the steam wand discharge are very hot and may cause burns.
- The steam wand tips and bases become hot during use: do not touch these surfaces.
- Cover the steam wand tip or submerge in a filled pitcher to safely divert the steam before opening the steam valve.
- Never remove the steam wand from the product that is being heated when the valve is open.
- Never remove the portafilter from the machine during the active brewing process.
- Keep water and moisture away from any electrical device or live power.
- Steam tank water is heated to 260°F (126°C) or more; Use caution near steam tank.
- The brew groups deliver water as hot as 210°F (99°C). Avoid exposure to this water.
- The hot water mix valve can be adjusted to deliver water as hot as 212°F (100°C), which can cause severe burns: please use caution when activating this water source.

Safety Label Locations:

Synesso™ complies with UL regulations by posting the following labels on its machines:

Electrical Box:	<p>WARNING: Disconnect from power supply before servicing</p> <p>AVERTISSEMENT: Couper l'alimentation avant l'entretien et le dépannage.</p>	California only:	<div style="text-align: center;">  <p>WARNING</p> </div> <p>This product can expose you to chemicals including lead, which is known to the State of California to cause cancer, birth defects, or other reproductive harm. For more information, go to www.P65Warnings.ca.gov.</p>		
Electrical	<table border="0" style="width: 100%;"> <tr> <td style="width: 50%; vertical-align: top;"> <p>The conductors of the power supply cord are marked "L1", "L2" for the ungrounded ("hot") supply conductors and "G" for an equipment grounding lead.</p> </td> <td style="width: 50%; vertical-align: top;"> <p>Warning: Risk of Fire. Use UL Listed Grounding Type Plug rated for 220 Volts, _____ Amperes, _____ Phase, # _____ Wire. Plug to be Selected and Installed only by Qualified Service Personnel.</p> </td> </tr> </table>			<p>The conductors of the power supply cord are marked "L1", "L2" for the ungrounded ("hot") supply conductors and "G" for an equipment grounding lead.</p>	<p>Warning: Risk of Fire. Use UL Listed Grounding Type Plug rated for 220 Volts, _____ Amperes, _____ Phase, # _____ Wire. Plug to be Selected and Installed only by Qualified Service Personnel.</p>
<p>The conductors of the power supply cord are marked "L1", "L2" for the ungrounded ("hot") supply conductors and "G" for an equipment grounding lead.</p>	<p>Warning: Risk of Fire. Use UL Listed Grounding Type Plug rated for 220 Volts, _____ Amperes, _____ Phase, # _____ Wire. Plug to be Selected and Installed only by Qualified Service Personnel.</p>				
Under drain tray	<p>This equipment is to be installed to comply with the applicable federal, state or local plumbing codes.</p>				

Materials information for Synesso™ machines:

- All stainless steel coming into contact with the water supply is 300 series
- All brass fittings are low lead per the CA360 specifications or better
- All electronic devices are lead free
- All gaskets are made from food-contact safe material

Test Information:

- Brew (coffee) tanks are hydrostatically tested to 375 psi
- Steam tanks are pressure tested to 75 psi
- The electrical system is subject to an electrical withstand test of: 1.20 kV AC for 1 second, with a 7 mA limit.

BREW & STEAM TANK SAFETY

Espresso machines have numerous potential hazards, and it is of paramount importance to Synesso that people servicing our machines take all necessary precautions to ensure their personal safety. When working on the machine's boilers (unless otherwise instructed in the directions):

- Turn the machine off and shut off the incoming water supply.
- Depressurize the boilers as shown below.

When working on any electrical wiring (unless checking voltage or amperage readings or otherwise instructed in the directions) ensure that the machine is switched off at the red on/off switch on the front panel and the machine is unplugged.

Depressurizing the Steam Tank:

1. Turn off the element circuit breaker located under the machine

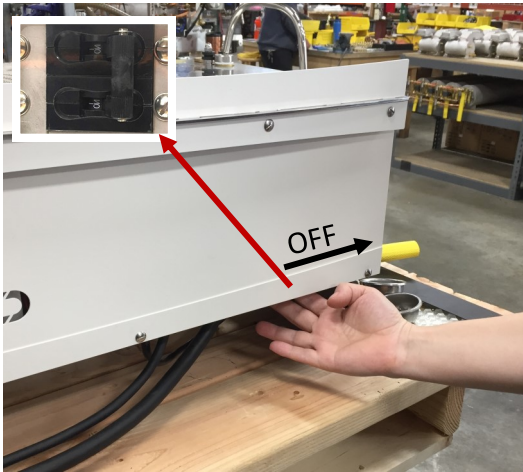

2. Open the steam valve by moving the steam actuator lever forward



3. The steam tank is depressurized when the steam gauge reads zero. Note: the steam gauge is rated @ 0-60 psi



Depressurizing the Brew Tanks:

1. Turn off the element circuit breaker located under the machine.
2. Also turn off the water supply to the machine.



3. In the second level menu, change the brew valves from "Normal" to "ON" this will bleed the pressure.

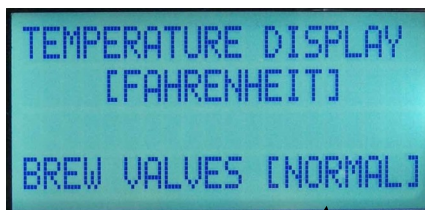

"NORMAL" to "ON"

4. The brew tanks are depressurized once the pressure gauge reads zero. Note – the brew gauges are rated at 0-300 psi



START UP SCREEN

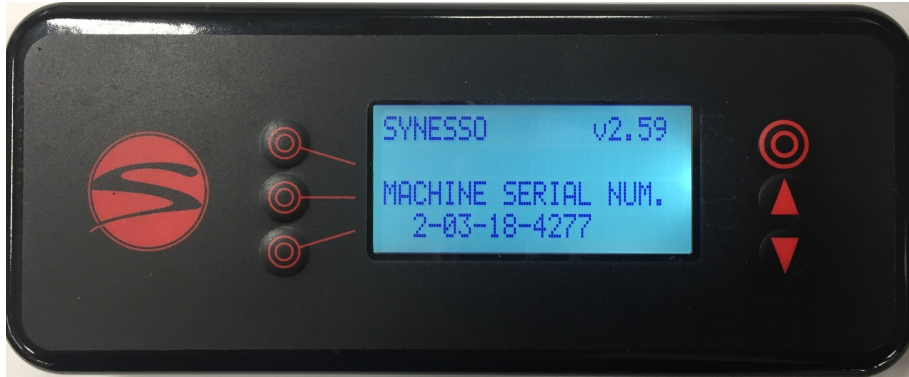

When power is turned on, this screen is shown, displaying the software version and serial number.

The serial number contains important information:

- 2—is the number of brew groups on this machine
- 03—is the month the machine was built
- 18—is the last 2 digits of the year it was built
- 4277—is the machine sequence number

RECOMMENDED TOOLS & SUPPLIES

Tools and recommended items required to fully diagnose, service and maintain Synesso espresso machines.

- Multi Meter – reads volts, amps and ohms
(The Fluke T5-600 is recommended)
- Heat Shrink Gun or Torch
- Vacuum with a Hose
- Compressed Air
- Descaler – Citric Acid
- Flashlight
- Box Knife
- Thread Sealant – Red and Blue Loctite
- Food Grade Grease (Super Lube) 1.8600
- Tube Bender for 1/4", 5/16", and 3/8" Tube
- Flare Tool - 45°
- Tube Cutter
- Brass Bristle Wire Brush
- 3/8" Drive Socket Wrench with 7/16", 1/2" and 9/16" "Deep Sockets"
- Hammer Medium Size Ball Peen
- Wire Stripper / Crimper
- Small Punch and Chisel
- 3/8" ID rubber tube for draining
- Small Files – Round and Triangular
- Picks – Straight and Curved, an Ice Pick is great for replacing portafilter gaskets
- Dies: 1/8" NPT, 1/4" NPT, and 1/8" BSPP
- Taps: 8-32, 10 - 32, 3/8 – 16, and M6 x 1 bottoming Tap
- Allen Wrenches: 3/32", 1/8", 9/64", 5/32, 3/16", 1/4" (steam valve seat)
- Wrenches: 2x11/32, 1/4, 5/16, 3/8, 2x7/16, 1/2, 2x9/16, 5/8, 11/16, 3/4, 12mm & 17mm
- Adjustable wrenches: Medium size 1 1/4" opening and Small for tight spots
- Pliers: Channel Lock, Standard pliers and Side Cutters
- Philips Head Screwdrivers: #2 short, #2 long and #1
- Flat Head Screwdrivers: #2 short, #2 medium length, #1 medium, #0 medium
- A large flat head screwdriver (or small flat nail puller) to use as a pry bar or wedge.
- Pen and paper
- Hand cleaner and Towels

WARRANTY & WATER STANDARDS

Limited 2 Year Plus Warranty

Synesso Inc. and/or your distributor warrants to the original purchaser that Synesso™ espresso machines are free from defects in materials and workmanship under normal use and service for the period commencing upon the date of shipping and continuing for 24 months from the original date of shipment. Synesso will make a good faith effort for prompt correction or other adjustment with respect to any non-wearing part that proves to be defective within the limited warranty period. The limited warranty is conditional upon proper use of the machine by the purchaser.

The limited warranty does not cover defects or damage resulting from: accident, misuse, abuse, shipping damage, neglect, unusual physical, electrical or electromechanical stress, unauthorized customer modifications or improper water filtration.

The 2 Year Plus Warranty* will cover all non-wearing parts including:

- Universal Brew Tank
- Steam Tank
- Marathon Motor
- Fluid-o-Tech Pump
- Pressure Relief Valve
- 1/4" Check Valves
- Thermal Overload Switch with Manual Reset
- Brew and Water Control Valves

In addition to the standard 2 Year Plus Warranty*, Synesso™ will cover the following items under a Limited 5 year Warranty:

- Steam Valve Actuator
- Machine Body
- Machine Frame
- Heating Elements
- Wire Harness
- Flow Meters
- Copper Tubes
- Brass Fittings
- Temperature Probes
- **Lifetime Warranty on Group Head Actuator Assemblies**

Wearing parts not included in the 2 Year Plus Warranty* are:

- Portafilter Gaskets
- Portafilter Baskets
- Portafilter Springs
- Group Diffuser Screens
- Steam Valve Seals
- O-Rings or Seals
- Gauges
- Vacuum Breaker
- Body Panels - One Year Warranty
- Purge Buttons - One Year Warranty

***To obtain the 2 Year &/or 5 Year Plus Warranty, the annual Preventative Maintenance Guide and checklist must be completed by a qualified Synesso Technician. After twelve months from the original date of shipment, the completed checklist must be emailed to the Synesso Technical Support Department. [Tech@Synesso.com] Checklists must be received before the thirteenth month from the original date of shipment in order to be valid.**

See page 33 for the Annual Preventative Maintenance Checklist.

WARRANTY & WATER STANDARDS

Proper water filtration and regular filter changes are a requirement to keep your factory warranty valid and your machine functioning properly. It is highly recommended that you contact a professional water filtration specialist in your area and have your water tested to determine the proper filtration system. It is important to note that many municipalities change their water sources throughout the year, so additional water tests may become necessary.

Water Standards to keep your warranty valid:

Total Dissolved Solids (TDS)	30 to 200 ppm (parts per million)
Total Hardness - in ppm	50 to 85 ppm
Total Hardness – in grains	3 to 5 grains (divide ppm by 17.1 to get grains)
pH	6.5 pH to 8 pH
Chloride	5-15 ppm – any Chlorides can be corrosive and harmful
Total Alkalinity	Less than 100 ppm
Chlorine	0 ppm
Iron	0 ppm

In Synesso’s experience, Everpure Claris and Cirqua formulator systems can damage the Synesso stainless steel tanks. Use of either system is highly discouraged and will void the water related parts of the machine warranty.

Any part which is determined to be defective in materials or workmanship should be returned to Synesso or to an authorized service location, shipping costs prepaid, as Synesso designates. Synesso may repair or replace the product or part with new or factory refurbished equipment at Synesso’s sole discretion. If the product or part is determined to be defective and in compliance with the Limited Warranty conditions, the replacement part or product will be returned to the purchaser with shipping prepaid **.

Many jurisdictions have codes and regulations governing sales, construction, installation, and/or use of products for certain purposes, which may vary from area to area. While Synesso attempts to assure that its products comply with such codes, it cannot guarantee compliance and cannot be responsible for how the product is used or installed.

Synesso’s liability is limited to the purchase price of the product and shall not be held liable for damages that extend beyond the product itself. Synesso’s liability of consequential, incidental damages, indirect or direct damages for personal injury, inability to properly use this product, loss of business profits or interruption to business is expressly disclaimed.

** Regarding equipment sold or residing outside the United States: purchaser may be required to pay for the shipping and associated costs for warranty parts, repairs and services. Please contact your local distributor to resolve the issue regionally, if possible.

PLUMBING REQUIREMENTS

This equipment must be installed to comply with the applicable federal, state or local plumbing codes. **WATER TREATMENT IS REQUIRED TO PRESERVE THE FULL MACHINE WARRANTY.** Please ensure that the incoming water complies with the warranty requirements listed on page 8.

Using the provided stainless steel braided hose, connect the pump to the shutoff valve on the filtered cold water line. Fittings on the hoses and pumps are 3/8" tube compression. Thread sealant or Teflon tape is not necessary. Make connections snug, but do not over tighten.

Turn incoming water ON and check for leaks.

Synesso machines require a minimum of 50 PSI (3.5 bar) of line pressure at 30 gal (120 L) per hour to have the auto-fill system, for the steam tank functioning properly. Please ensure that the incoming water meets this requirement or contact Synesso for alternative methods of boosting water pressure.

NOTE: Synesso sells a "Euro-hose" adaptor hose and fitting which converts from a 3/8" tube fitting to a pipe fitting, suitable for most non-US plumbing. Please refer to the picture below to identify the differences between the standard and Euro-style fittings and hoses.

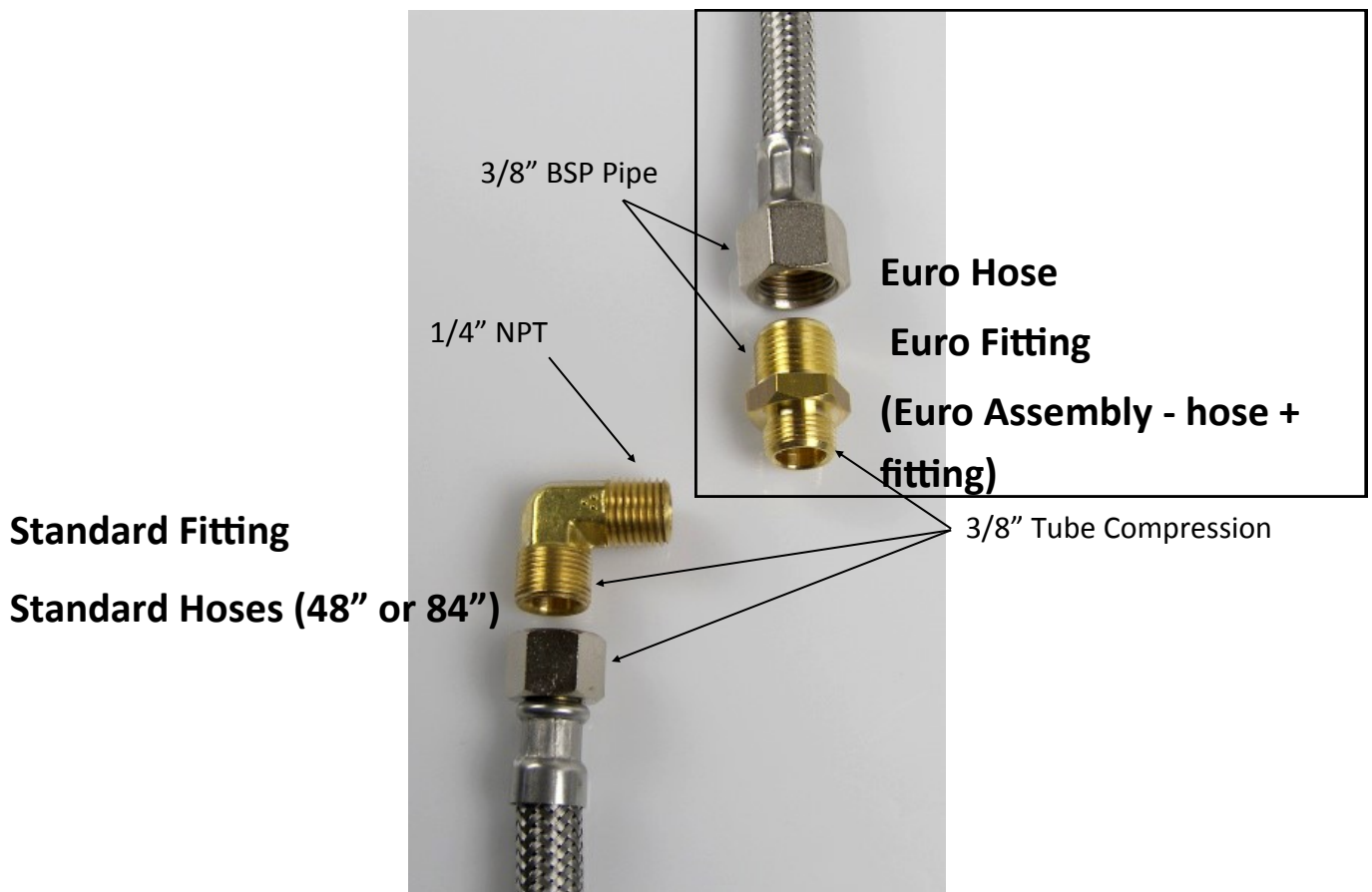

ELECTRICAL REQUIREMENTS

All Synesso machines are rated to operate on 220 VAC / 60 Hz or 230 VAC / 50 Hz frequency, single phase. Machines will operate between 208 V and 240 V.

Listed amp ratings are all measured at 220 V. Incorrect voltage can cause malfunction or damage to the machine. **Plug or means of isolation must be easily accessible.**

An electrical socket and matching plug, rated at the proper voltage and amperage are required within three feet of the machine. Plug ends are NOT included with the machine unless required by CSA or other certification.

Model	Cord Plug Rating (UL Listed)	Machine Max Amp Draw	Machine Max Watts
S200	30 amp	28 amp , 220 V / 60 Hz	5956 Watts, 230 V / 50 Hz
S300	40 amp	36 amp , 220 V / 60 Hz	7656 Watts, 230 V / 50 Hz

North American Wire Color		Worldwide Wire Color	
Green	Ground	Green and Yellow	Ground (Earth)
White	110 V Line 1	Brown	230 V
Black	110 V Line 2	Blue	Neutral

Attach the plug end per manufacturer's instructions.

Make sure that the electronics switch and the heating element breaker are in the OFF position, then plug the power cord into the receptacle.

OPTIONAL: If recovery time is slow, or voltage is low, you may install an In-Line Buck-Boost transformer. Buck-boost transformers come in different sizes. Please choose the appropriate one for your machine if required. Machines require a 1.0 KVA transformer.

SPECIAL ELECTRICAL INFORMATION FOR EMC-COMPLIANT MACHINES

(CE FOR EUROPE AND OTHER LOCATIONS)

To comply with EMC (Electromagnetic Compatibility) regulations, machines built prior to May 2019 included a capacitor in the electronics box across the main power IN. **To avoid an electric shock from the charge held in the capacitor, unplug or isolate the machine with the electronics ON/OFF red rocker switch in the ON position.**

INSTALLATION & WORK STATION

To maintain the 2 year warranty, an authorized or certified espresso service representative must perform the installation of this espresso machine.

Site Preparation - See Diagrams pages 12-13. The machine must be placed on a level horizontal surface that can be easily cleaned and is capable of supporting a minimum of 300 lbs.

The counter top requires a depth of 28", which provides a minimum clearance of 1" behind and 3" in front of the machine.

The height of the surface can vary to suit the operator.

Make a 2 ½" minimum diameter hole through the counter top located according to the diagrams on pages 12 and 13. The hoses, drain tube, and electrical lines will all pass through this hole.

A 3/8" min. diameter cold water supply line from the filter with a shut off valve is required within 5' of the machine. The valve should be easily accessed for machine service.

The machine supply hose and pump fittings are 3/8" tube compression fittings.

A proper water filtration or softening system must be installed on the incoming water supply. Water treatment requirements will vary, and it is important to use a system designed to match the needs of your specific area. Water filtration systems require periodic maintenance, including cartridge or filter replacement. Proper filtration and service is vital to the function of the machine and the quality of the espresso served. Follow the instructions provided by your water treatment system for proper installation.

Note: Improper water filtration can result in severe damage to the machine including scale deposits and corrosion. **DAMAGE CAUSED BY IMPROPER WATER TREATMENT WILL NOT BE COVERED BY THE MACHINE WARRANTY.** See page 8.

There must be adequate room under the counter to locate the motor and pump. The pump must be easily accessible for adjustment, and the motor must have a minimum of 3" clearance on all sides for air flow.

A floor drain or sink must be available. The best location is directly under the machine. The 3/4" drain hose should descend as vertically as possible for optimal drainage. An air gap is required between the end of the drain hose and the highest water position of a clogged drain. This is to prevent the possibility of drain water backing up into the machine.

INSTALLATION & WORK STATION—S200

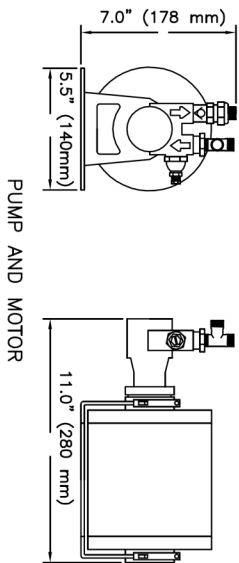
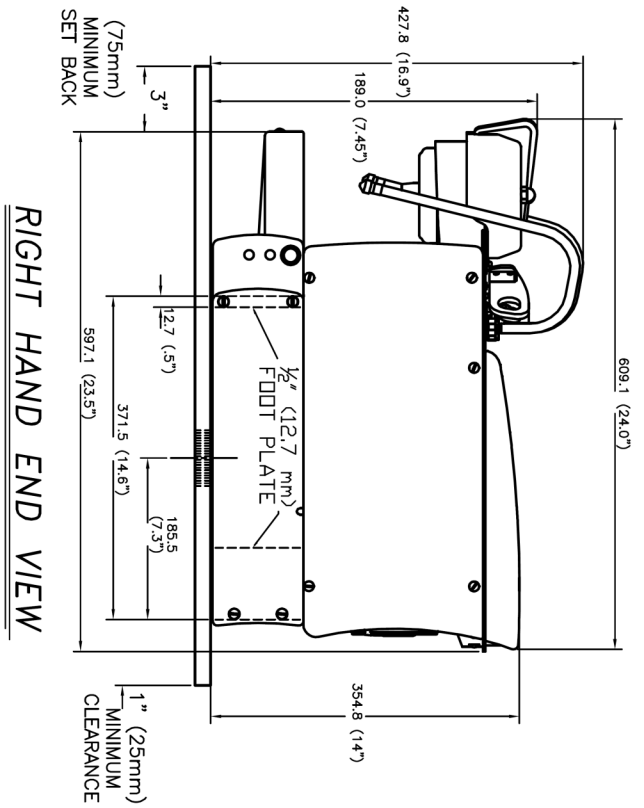
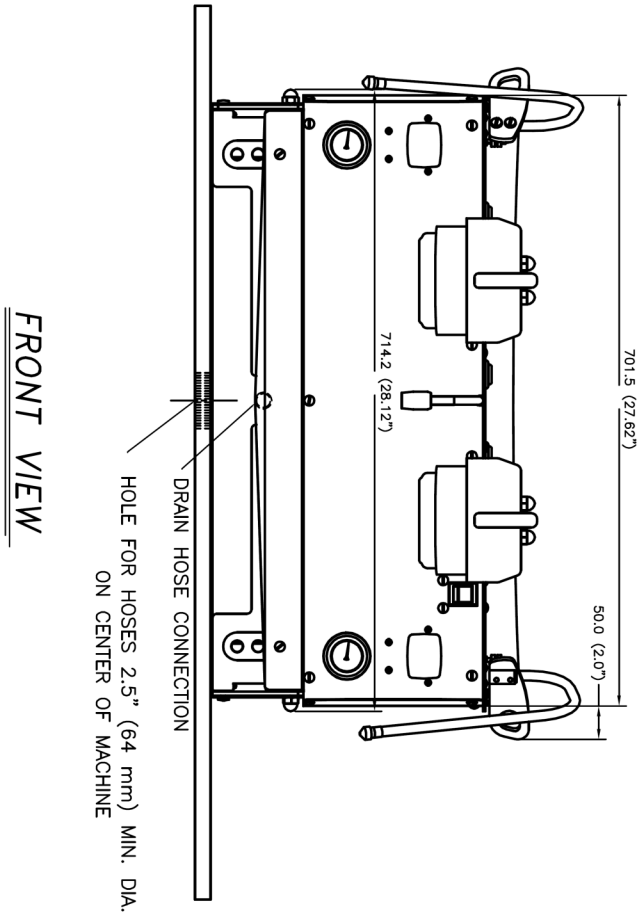

INSTALLATION & WORK STATION—S300

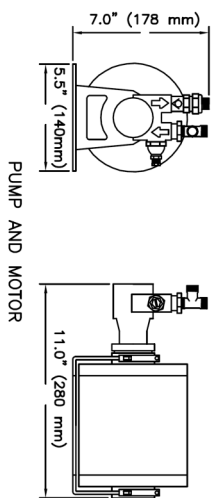
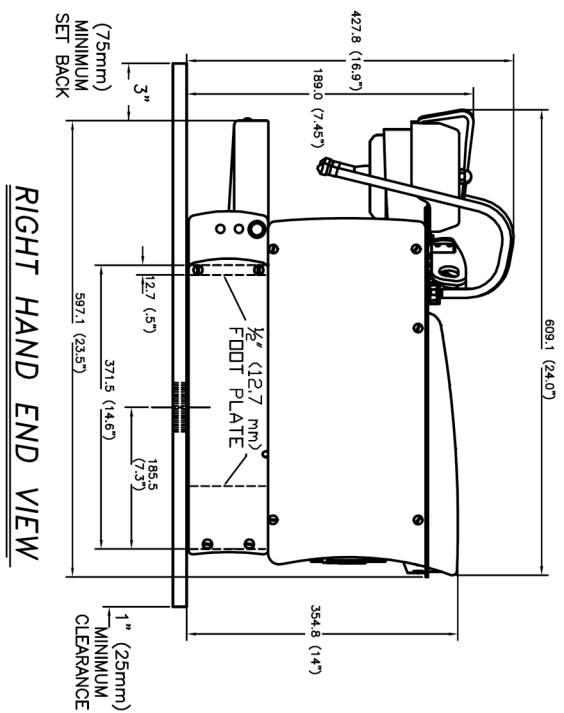
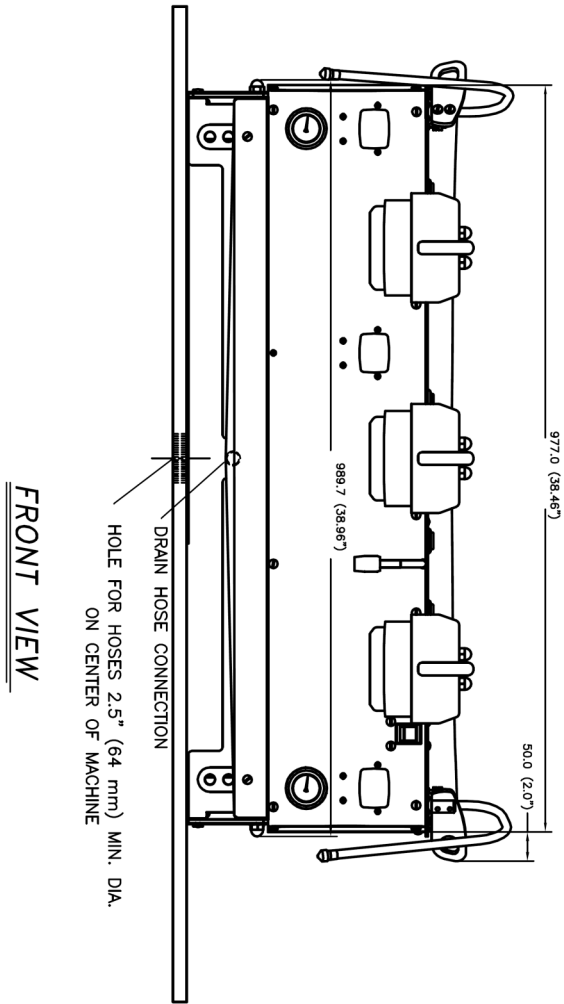

START UP

First Time Start-Up Instructions

1. Connect the water lines and the drain hose. Turn the water ON. Water will begin to flow into the brew groups.
2. Ensure the heating element breaker switch is in the OFF position. Then switch the red electronics On/Off switch to the ON position. The machine's auto-fill feature will activate and the steam tank will begin filling.
3. Bleed the air from the group heads by running each group until water flows without sputtering.
4. When the steam tank has stopped filling, set the heating element breaker to the ON position. The machine will begin heating to the set temperatures.



**Heating Element
Switch**

ON: left position (1)

OFF: right position (0)

5. To set the pump pressure to 9 bar, locate the pump adjusting screw on the right side of the brass pump housing. Loosen the lock nut and turn the screw with a screwdriver (Clockwise to INCREASE pressure, Counterclockwise to DECREASE pressure). Make adjustments while running the shot programs to see the current pump pressure. Once the desired pressure is reached, retighten the lock nut.
6. Please allow at least 30 minutes of “warm up” time before using your Synesso™ espresso machine to brew shots or steam milk. The steam gauge (the left hand gauge) should read a minimum of 1.1 bar before the steam tank is at an operational pressure and will stop at 1.3 bar when the factory set temperature of 250°F is reached. The factory set temperatures for each brew tank is 203°F. Temperature readings for the steam and brew tanks are displayed on the handheld controller. Temperature set points can be adjusted by following the instructions on pages 19 and 20. Once the readings are at the set temperature, the machine is fully operational and ready for use.

Note: As the brew groups heat, the needle of the brew pressure gauge may rise above 11 bar. There is an expansion valve used to control the maximum pressure achieved. This valve is positioned to bleed into the drain tray of the machine and is accessible for adjustment from the front of the machine without having to remove machine panels. The expansion valve is factory set to bleed off pressure at 11-12 bar. If the needle rises above 12 bar on the pressure gauge, the expansion valve should be adjusted to bleed off pressure near 11-12 bar so that the maximum pressure reading of the brew gauge cannot exceed 12 bar. The expansion valve requires periodic adjustment throughout the lifetime of the machine to ensure that the pressure in the brew system is not able to increase above 12 bar.

7. Once the steam pressure gauge reads at or above 1.1 bar, you may purge the steam wands. To purge the steam wands, first position the wand tip into the drain tray. Activate the steam wand by pulling the steam wand handle toward you. After allowing steam to escape for several seconds, turn the steam off by returning the handle to the resting position.

OPERATION

Introduction to S Series Operation

S Series machines are designed to operate as fully volumetric machines. This means that any time a group is activated, it will run the selected program until the set volume has been dispensed. S Series machines do not have a manual operation mode.

S Series machines come with a single pump/motor. They are designed to operate with two stages of pressure profiling for brewing espresso. The shot begins with preinfusion. Low pressure water saturates the puck, swelling it to reduce channeling. After the programmed preinfuse time has elapsed, the full pump pressure (typically 9 bar) stage begins. This stage will continue until the programmed volume of water has been dispensed. The pump and brew group then shut off to end extraction, returning the machine to idle pressure.

S Series machines come equipped with a handheld controller and LCD display to allow for adjustments of the machine tank temperatures and brew parameters. Each brew group has two available programs which can be easily accessed and adjusted through the controller.

Preparing to Brew Espresso

1. Select the desired spout and basket configuration. Single, double and bottomless portafilters are available through Synesso™. The single spout portafilter is used with a single (7g) basket to brew a single shot. The double spouted and bottomless portafilters can be used with double (14g) or triple (18g or 21g) baskets to brew double or triple shots. The double spouted portafilter can separate a double shot into 2 single shots of espresso.

2. Fill the portafilter basket with coffee grounds to just above level and wipe off the excess.

Note: For best results, use fresh coffee. Ground coffee should be brewed as soon as possible after grinding.

3. Press straight down evenly on top of the grounds with the tamper. (A tamper is supplied with the machine).

4. If desired, purge the group to heat the diffuser before proceeding to the brewing process. S Series machines have purge buttons, which will dispense a timed pulse of full pressure water to aid in cleaning or warming the group between shots. Set the duration of the purge in the handheld controller.

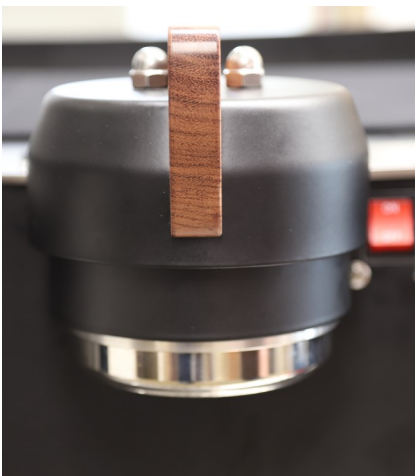

Center Position - At Rest

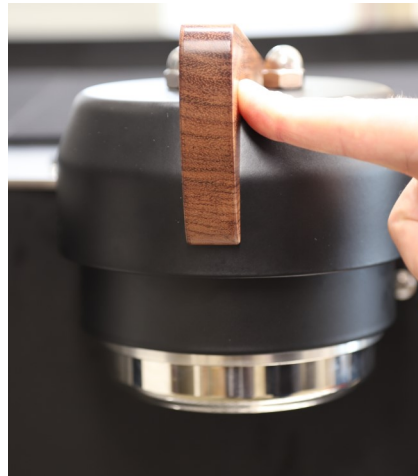

Shift Left - Start Program 1 or Stop

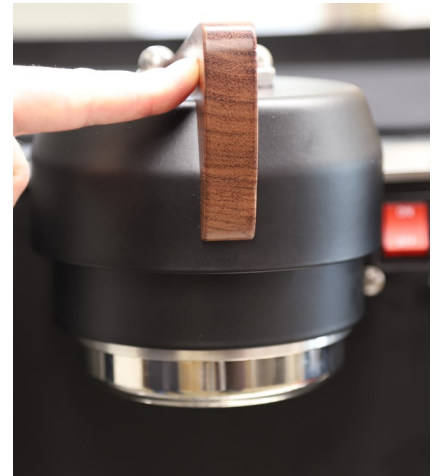

Shift Right - Start Program 2 or Stop

OPERATION

Brewing Espresso

1. Engage the prepared portafilter into the brew group that has the correct temperature setting for this espresso roast and pull handle firmly to the right to set the seal.
2. Shift the group head either to the left to run the left program or to the right to run the right program.
3. The program will preinfuse the puck for the set time, then engage the pump.
4. Once the set amount of water has been dispensed, the shot will end automatically.
5. You may change the preinfusion time and shot volume by using the handheld controller (see page 20 for programming instructions). Make changes between shots, not while brewing.
6. To stop a shot early, shift the handle in either direction or press the purge button.
7. After the shot, remove the portafilter, tap out your spent puck, and clean the basket.
8. Purge the group. S Series machines have purge buttons, which will dispense a timed pulse of full pressure water to aid in cleaning the group between shots. Set the duration of the purge in the handheld controller.

Shot Timer Display



Program 1 (Left Shift)



Program 2 (Right Shift)

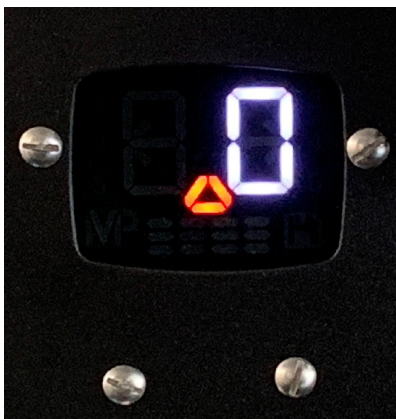

Flashing Triangle

Low Flow (occurs during brewing) or
Low H2O (accompanied by beeping)



Flashing Triangle / Time Out

Low Flow (shot is stopped)
Brew Valve Time Out
Shift Group Handle to Clear

OPERATION

Milk Steaming

1. Fill the pitcher halfway with fresh, cold milk. Smaller pitchers are recommended for drink sizes less than 10 oz. **Note:** Steamed, unused milk should be discarded and the pitcher rinsed before using.
2. Purge the steam wand by activating it momentarily. This will expel any water in the wand that has collected due to condensation between uses.
3. Insert the tip of the steam wand deep into the milk pitcher. This will prevent milk from splashing once the steam is turned on.
4. Open the steam valve by pulling the handle towards you.
5. Place one hand on the side of the steam pitcher to feel the rising temperature of the milk.
6. While the milk is still cold, lower the pitcher until the tip of the steam wand is near to the surface. Allow the steam jets to push some air beneath the surface, then raise the pitcher to lower the tip of the wand deeper into the milk. **Note:** The more air pushed into the milk, the more foamy the texture will be. Generally not more than a second of aeration is needed for latte foam or several seconds for cappuccino foam.
7. Continue steaming the milk while the wand is submerged. This will continue the heating process and minimize further foaming. Do not touch the steam wand to the bottom of the milk pitcher; this can create an inaccurate temperature measurement.
8. Heat the milk to approximately 150°F to 170°F (65°C to 76°C) then deactivate the steam wand. If you are using your hand to help determine the temperature, it will feel about as hot as you can stand without burning yourself. Milk thermometers are also an excellent way to determine the temperature of the milk.

Caution: Do not overheat the milk and scald it. Scalded milk should not be used.

9. Remove the wand from the milk, purge with steam, and wipe clean immediately after each use.

Note: The steam wands should be purged before and after each use. Failure to purge the wands may allow the steamed liquid to travel back through the wand and cause steam valve failure and spoiled, scalded milk flavor. These issues are fully preventable by habitually purging the wands, as described above, and keeping the machine up-to-date on preventative maintenance.

Note: Although Synesso™ steam wands are made with a proprietary double-walled process that helps to keep the outer wall cooler, the tip and base can become very hot and caution must be used.

Cleaning and Maintenance:

Machine upkeep is essential in order to ensure a long lifetime of the machine and the proper functioning of all components. Users should perform routine cleaning and schedule routine preventative maintenance to keep the machine at optimal performance.

For more on Synesso recommended cleaning and maintenance procedures for the machine, please refer to pages 30-33 of this manual.

PROGRAMMING

Overview

S Series machines have a handheld (wired) controller, pictured below, to allow the user to comfortably view and change the machine settings.

To change settings on these screens, first press the line button on the left side of the display associated with the setting you wish to change. The value will flash once selected. Press the up or down buttons until the desired value is displayed. Press the line button again to confirm the change. The value will stop flashing. Use this procedure to change any variables in the controller menus.

Menu Level 1: Temperature Overview; Home Screen



The top line of every screen indicates the title. In this case, Temperature Overview.

You can return to this screen at any time by pressing the home button at the top right of the controller. The machine will also return to this screen automatically after a short time.

Lines 2, 3, and 4 may contain information or settings, many of which can be changed by the operator. This screen provides the current temperatures for each brew group along with the steam tank. The most recent error will also be shown in the lower right corner. No settings can be changed on this screen.

In some circumstances, numeric temperatures will not be shown. If a tank is reading 'LOW', this indicates that the tank is below the temperature probe's effective range of measurement (170°F-270°F / 76.6°C-132.2°C). Readings above the effective range will show as 'HIGH'.

The programmable temperature range for a brew group is from 180°F (82.2°C) up to 220°F (104.4°C). The factory set temperature is 203°F (95°C). To change brew group set temperatures, refer to page 19.

The steam tank is set in factory to a default setting of 250°F (121.1°C). To change this temperature setting, see page 20.

The [OK] on the right hand side of line 4 is indicating that there have been no errors detected by the control system. If, in place of the [OK] you find an error code (Ex: STLW01), refer to the Error Log codes on page 22. To cycle to the next display screen, press the down arrow button. (You may press the up arrow instead to travel back to the previous screen.)

PROGRAMMING

Factory Settings:

The factory settings for your machine are as follows:

Brew Group Temperature	203°F
Steam Tank Temperature	250°F
Program Mode	Universal (2 programs)
Temperature Units	Fahrenheit

Left program:

Pre-Infusion	4 seconds
Total Water Count	280

Right program:

Pre-Infusion	4 seconds
Total Water Count	380

Menu Level 1: Brew Temperatures

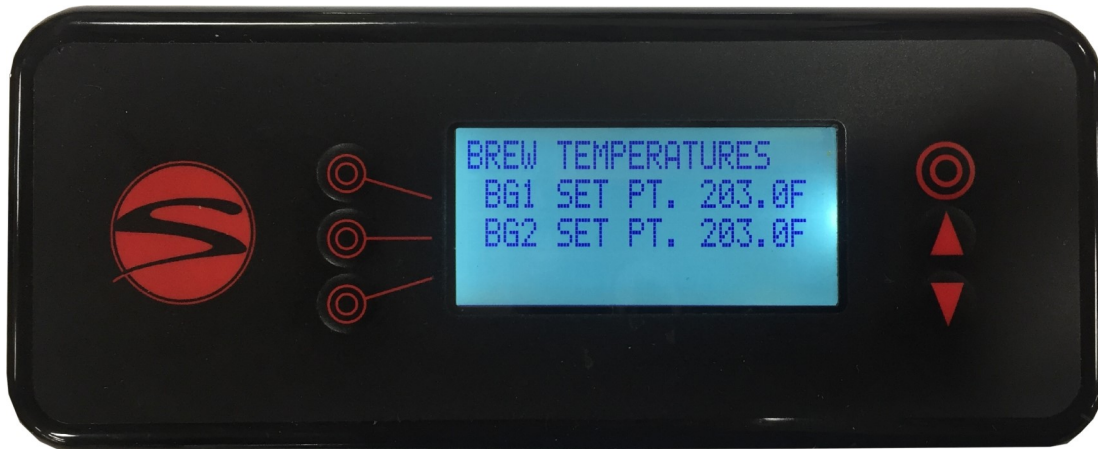

The set point is a goal temperature for the brew tank. The tank will heat to reach the set point, then use a PID based algorithm to remain stable and balanced at that temperature when in use.

Allow 10-15 minutes for a brew group to adjust to a large set point change. Smaller changes take less time to restabilize.

Line 2 indicates the set point for brew group 1, in this example "203.0F".

Line 3 indicates the set point for brew group 2, in this example "203.0F".

To cycle to the next display screen, press the down button.

PROGRAMMING

Menu Level 1: Programs

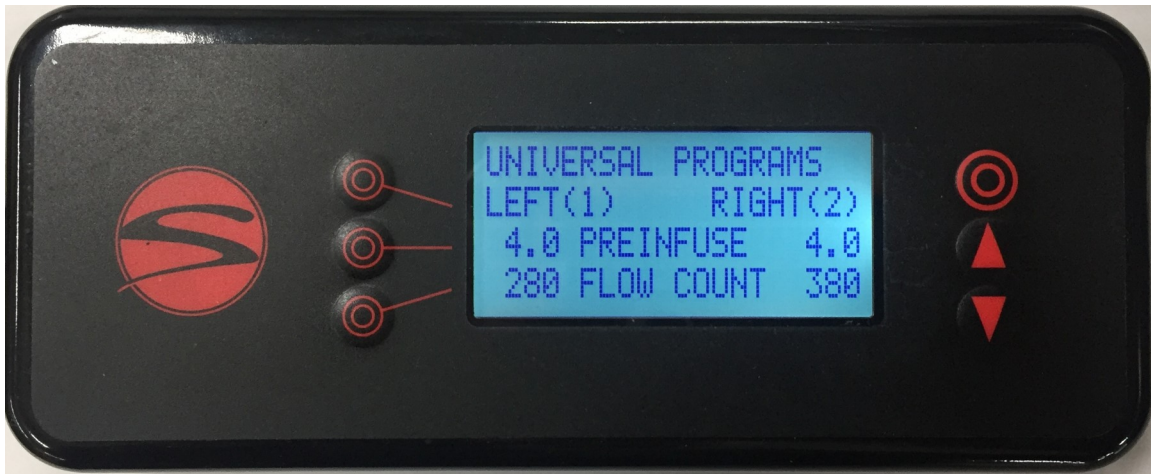

If the machine has been set to universal program mode, you will be able to change the “Left” and “Right” program, setting the preinfusion time and water count for each. Each brew group will use these programs. This is the default mode.

If the machine has been set to individual program mode, there will be a separate page for the left and right programs on each brew group. This allows the groups to use different programs. This mode can be selected in the 2nd level menu. (See page 23)

Line 2 indicates program 1, activated by a left shift of the group top handle and program 2, activated by a right shift of the group top handle.

Line 3 indicates the adjustable preinfusion values in seconds for the left and right programs. If the value is adjusted to 0 seconds, the preinfusion stage will be skipped.

Line 4 indicates the adjustable flow count values. There are about 4.5 counts per milliliter of water dispensed. Some of this dispensed water is absorbed and retained by the coffee puck, but generally, if you add 9 counts, you should receive 2 additional mL of water.

To cycle to the next display screen, press the down button.

Menu: Steam Tank and Hot Water Tap



Please see next page for details.

PROGRAMMING

Steam Tank and Hot Water Tap Continued...

From the picture on the previous page, Line 1 shows the current reading of the steam tank temperature probe (250.8F in this example). Once this temperature reaches the set point, the digital display will continuously adjust in small increments as the electronics balance the temperature.

Line 2 is indicating the set point of 250.0F (121.1C). The adjustable set range for the steam tank is between 200F and 265F (93.3C and 129.4C).

Line 3 is showing the hot water tap run time. To avoid excess water use, set this as low as you can.

To cycle to the next display screen, press the down button.

Menu Level 1: Purge Button Time

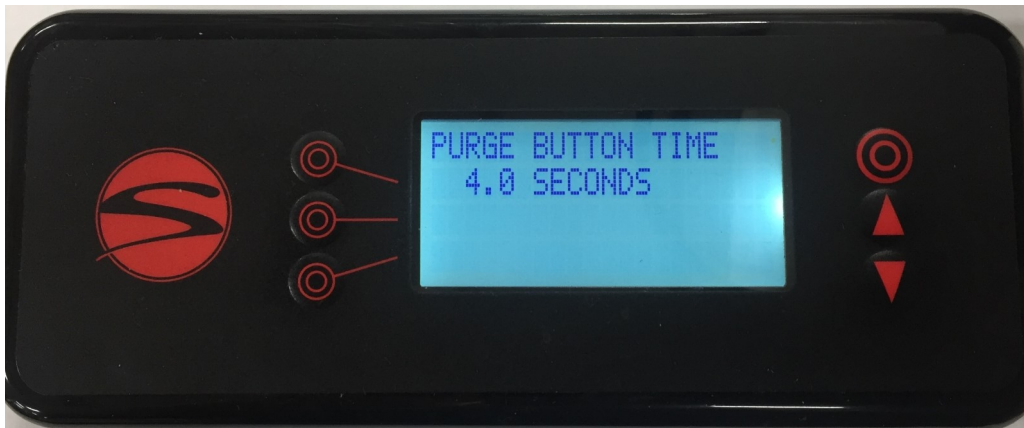

Line 2 indicates the adjustable amount of time that the purge will run before shutting off. This setting is used for all purge buttons.

To cycle to the next display screen, press the down button.

Menu Level 1: Auto Backflush

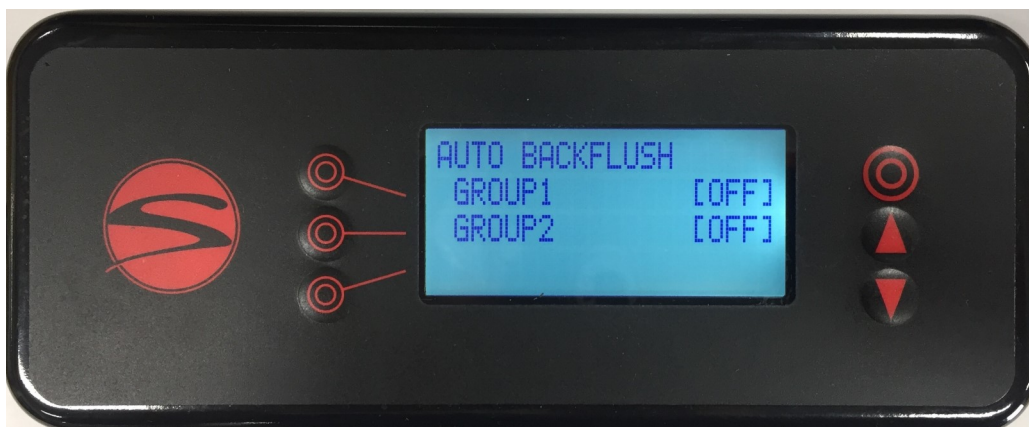

Auto backflush can be activated by pressing the line button associated with the group you want to flush. Set the value to “ready”, then place a portafilter equipped with a blind basket into the selected brew group. Shift left on the group head. The selected group will run the brew valve and motor for 10 seconds, followed by 10 seconds off. This will repeat 5 times. The shot timer will count up to 10 to let you know when it is running. Upon completion, the timer will read 10. Remove the portafilter and thoroughly clean the diffuser screen.

Please continue to the next page for more details.

PROGRAMMING

Auto Backflush Continued...

If you have used soap or another cleanser during the backflush, run the backflush process a second time with no soap or chemicals to rinse the internal tubing and brew valve. Failure to rinse after a soap backflush can leave soap residue in the brew valve affecting taste and/or machine behavior.

Any number of brew groups can use the auto backflush feature at the same time. The auto backflush can be interrupted mid-cycle by moving the brew head to either side, pressing the purge button, or by turning the setting on the controller back to "off".

To cycle back to the temperature overview screen, press the down button.

Menu Level 1: Brew System Error Codes

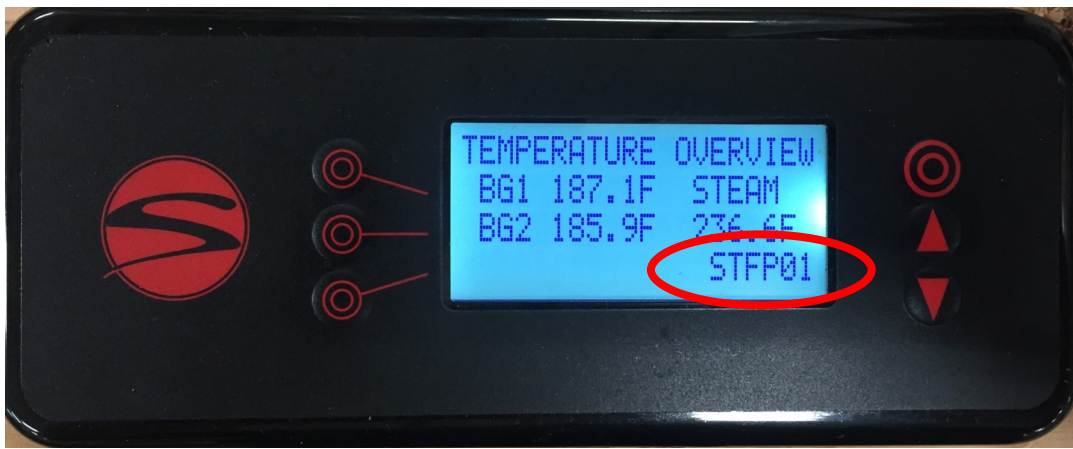

In an effort to prevent damage to machines and to help operators troubleshoot issues, Synesso has engineered several safeguards into the programming. By understanding these codes, operators can remedy issues more quickly. The most recent error can be found on the temperature overview screen at the lower right corner. An error found there is not necessarily happening currently.

BR - Brew System Codes	GROUP 1	GROUP 2	GROUP 3	CODE DESCRIPTION
BV - Brew valve	BRBV01	BRBV02	BRBV02	Brew Valve has been on for 5 consecutive minutes
OT - Over Temp	BROT01	BROT02	BROT02	Over Temperature (220°F)
UT - Under Temp	BRUT01	BRUT02	BRUT02	Group reads < 180°F for 1 minute while reheating
ST - Steam System Codes				
LOW H2O	LOW H2O			Low level probe not in contact with water (audible alarm)
LW - Low Water Probe	STLW00			Indicates past LOW H2O warning
FP - Fill Probe	STFP00			Fill Probe is not in contact with water for 1 minute
FV - Fill Valve	STFV00			Fill Valve has been on for 5 consecutive minutes.
OT - Over Temp	STOT00			Over Temperature (270°F)
VM - Volumetric System Codes				
UF - Unexpected Flow	VMUF01	VMUF02	VMUF02	Unexpected flow detected while group is off

PROGRAMMING

There are 3 levels of menus a technician can access through the wired controller:

Menu level 1 described on pages 18-22 contain settings relevant to the day-to-day operation of the machine.

Menu level 2 contains settings relevant to technicians and machine owners.

To access menu level 2:

1. **Press the home button (upper right) to return to the temperature overview screen**
2. **Press and hold the home button.**
3. **Press and release the lower left button, then release the home button.**

Menu Level 2: Program Mode



This is the first screen of the 2nd level of menus, the program mode select screen.

Line 2 toggles between universal program mode and individual program mode.

In universal mode, the “Left” programs on both groups are the same. Likewise, the “Right” programs on both groups are the same.

In individual program mode, the “Left” and “Right” programs on group 1 are not tied to group 2’s programs.

Menu Level 2: Temperature (F or C)

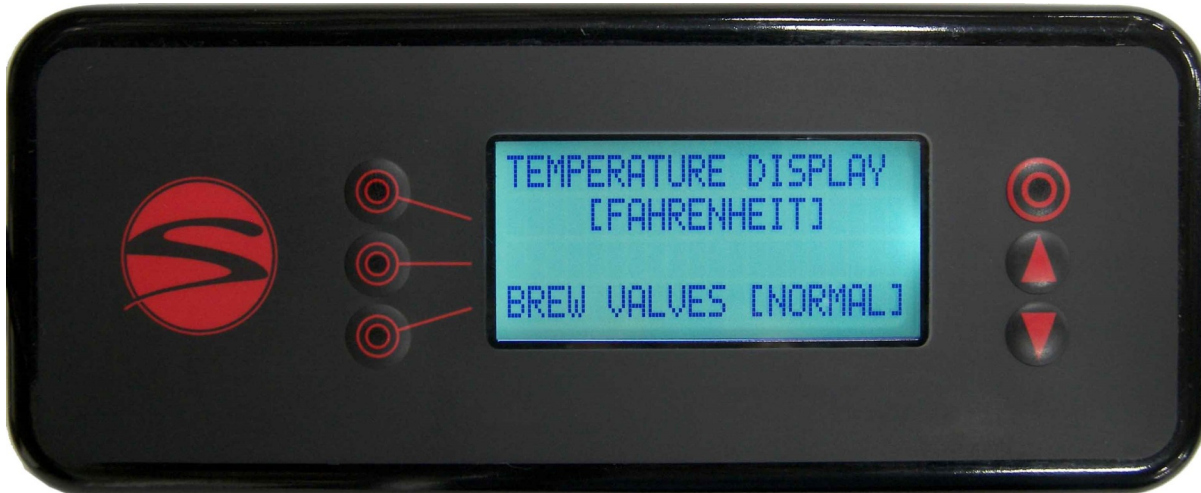

This is the temperature display screen.

Line 2 indicates the temperature scale that you are currently in (Fahrenheit or Celsius).

Line 4 indicates the operation status of the machine’s brew valves. Continue to the next page for details on the brew valves function

PROGRAMMING

Note on Brew Valve Setting

Setting the brew valve function to [ON] will activate all the brew valves, allowing the pressure to be bled from the brew tanks. Before draining the tanks, turn off the heating element breaker. Once the pressure has dropped, turn the brew valve setting back to [NORMAL] and attach the appropriate drain hose to the brew group's drain fitting. Turn the brew valve setting back [ON] once the drain hoses are securely attached. This will allow the water in the brew groups to fully drain in approximately 5 minutes. When the brew groups are finished draining, set the brew valve indicator back to the [NORMAL] setting. If the draining process takes longer than 5 minutes, the machine's safety programming will automatically turn the brew valve indicator to the [NORMAL] setting while exiting back to the temperature overview screen. If more time is needed, return to the Temperature Display screen and set the brew valve display back to the [ON] position to finish the procedure. Once finished with the draining procedures, make sure the brew valve indicator is set back to the [NORMAL] position.

Menu Level 2: Line Pressure Boost



If the machine has an optional line pressure boost pump installed, you will see this menu screen, otherwise it will not be shown.

“AUTO” is the setting on line 2 for normal operation. In “AUTO” mode, whenever a brew valve or water control valve is activated, the power board will also trigger a pump relay to run a line pressure generating pump and motor package. If this is set to “OFF”, the line boost motor will not activate. The “ON” setting will run the boost motor constantly. This is factory set to “OFF” to protect the boost pump from running without water.

PROGRAMMING

Menu Level 2: Brew Offset



Line 2 indicates the measured water temperature at the selected brew group's temperature probe.

Line 3 indicates the temperature adjustment made at the Synesso factory, in order to match the measured temperature with the temperature desired inside the puck.

Synesso keeps a log of the factory offsets for each machine. Contact Synesso Technical Support if you need to obtain the original factory-determined offset values.

The Synesso Temperature Testing Method

Using a bottomless portafilter, dispense 16-18 grams of coffee into a 14 gram basket with a thermal probe inserted 1/8th of an inch from the surface and in the middle of the puck, packing and tamping the grounds in the basket as usual.

The thermal probe is then wired to a calibrated FLUKE thermometer to relay the actual temperature of the water flowing through the puck while pouring a 25 second, 2 ounce shot. This process is repeated a minimum of 3 times per brew group in order to get the most accurate readings. The difference between the measured puck temperature and the raw tank temperature becomes the brew offset

This offset should not be altered without thoroughly testing the puck temperature, as described.

PROGRAMMING

Menu Level 2: Steam Offset



Line 2 indicates the measured steam temperature at the steam tank temperature probe.

Line 3 is the offset used to calibrate the steam tank temperature and pressure so that when the steam tank is set at 250°F, there is about 1.3 bar pressure on the gauge.

Line 4 of this display screen is showing a 5 second delay. The fill probe will wait this long before turning the steam tank fill valve on or off. Add time here if the machine is in an unstable installation such as a food truck or catering cart. There is no need to drop this time below 5 seconds.

Synesso keeps a log of the factory offsets for each machine. Contact Synesso Technical Support if you need to obtain the original factory-determined offset values.

Menu Level 2: Calibrate Flowmeters



The flowmeter calibration feature is made available with firmware v2.64.

The feature allows for technicians and advanced users to calibrate the flowmeters in order to achieve extreme accuracy in their output volumes or to recalibrate flowmeters that have become less accurate over time due to mineral buildup.

Line 3 allows the operator to begin the calibration. Before performing the calibration please read the instructions on page 34. Instructions should be carefully followed in order to ensure proper volumetric functioning of the machine.

To cycle to the next display screen, press the down button.

PROGRAMMING

Menu Level 2: System Clock



This is the system clock screen.

Line 2 allows the operator to set the local time in a 24 hour format.

Line 3 and 4 allow the operator to set the current date.

The date and time are used for the error log. A small battery on the power board should keep the clock and calendar running if the machine loses power, but it will need to be replaced eventually. Refer to the markings on the battery for replacement info.

Menu Level 2: Heating Elements

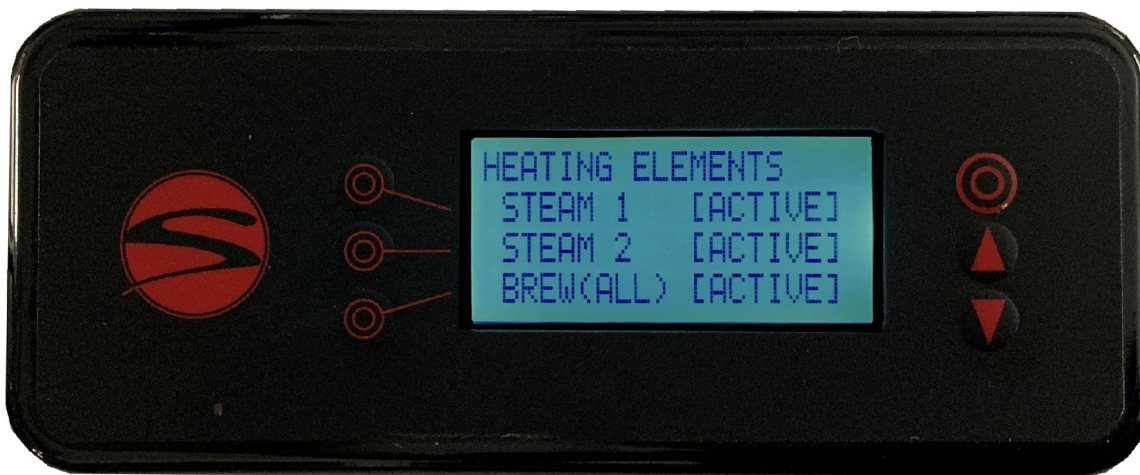

The steam element requires a lot of power to heat. We split the load onto 2 parallel circuits, each with their own relay, which can be deactivated independently here. This is useful for some troubleshooting.

Leave both lines in ACTIVE mode unless circumstances warrant.

You may also turn off the brew elements. This is helpful when cooling the machine or troubleshooting. Leave the brew elements active under normal circumstances.

PROGRAMMING

Menu Level 2: Error Log



Line 1 of the error log screen shows how many errors the machine has recorded, up to the 35 most recent errors, and which of these you are currently viewing. This example is showing the second of two errors.

Line 2 indicates the error code. If the error log is clear, this line will simply read 'NO ERRORS'

Line 3 indicates the date and time that the last error has occurred. If no error has occurred, this line will be blank.

Line 4 gives the option to scroll through or clear the error log. To view older errors, press the 4th line button once, which will make [SCROLL] flash. Use the up and down buttons to change the viewed error. Press the 4th line button again and [CLEAR] will begin flashing instead of [SCROLL]. Press the 4th line button again to deselect both options.

To clear the Error Log, press the 4th line button 2 times so that [CLEAR] is flashing. Press an arrow button to select clear. The 4th line will ask you to confirm clearing the error log as shown below.

Change the flashing [NO] to [YES] to immediately clear the log. Press the 4th line button with [NO] still flashing to exit without clearing the log.

See page 22 for descriptions of the error codes you may see.

Menu Level 2: Return to Operations



This is the last screen in the second level of menus.

Pressing the 3rd line button will take you back to the temperature overview screen in the 1st level of menus.

PROGRAMMING

Firmware Updates:

The machine's firmware is the basis for all of its programming features as made available by the handheld controller. Synesso provides updates to the firmware as needed in order to make improvements to the functionality of the machine. **Firmware updates require access to the electrical box and main electronics board of the machine and must be performed by a qualified technician.**

S Series machines run off of firmware versions 2.xx, starting with version 2.59 and proceeding up until the current version 2.64 (as of 2020). If the machine is running off of an older firmware version and you would like to update to the current version—so as to make certain features available and receive the most improved machine functionalities—please have a qualified technician reach out to Synesso Technical Support. One of our technicians can provide the latest firmware and instructions needed to perform the update.

The firmware that is currently installed on the machine can be viewed on the start-up screen of the handheld controller when powering the machine on (see picture below).

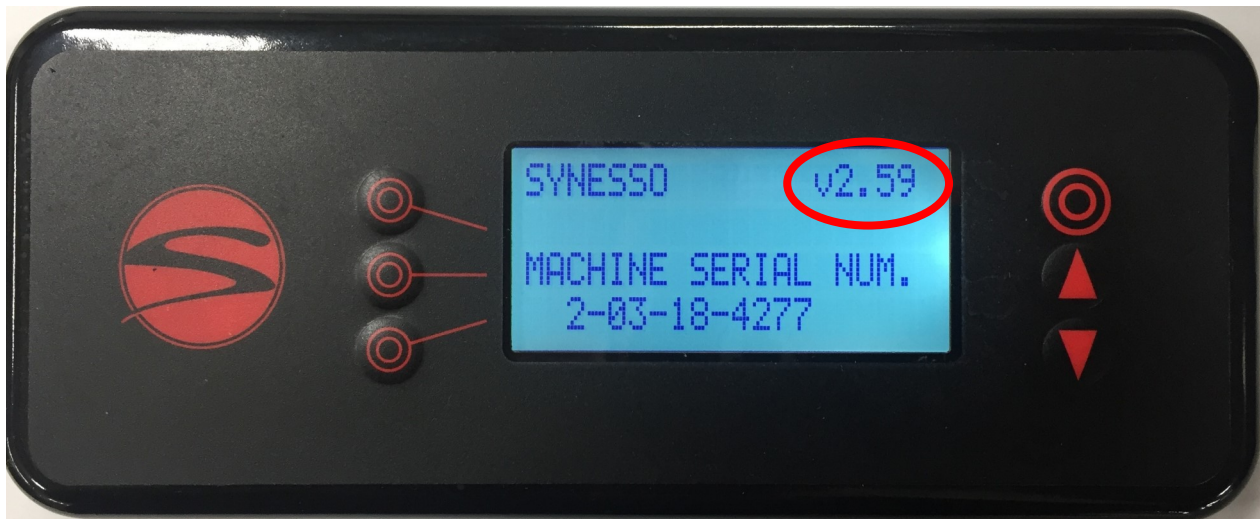

This start-up screen appears momentarily when the machine power is cycled on. The firmware can be viewed in the upper right corner of the screen, in this case v2.59.

MAINTENANCE

DAILY MAINTENANCE

Daily cleaning and maintenance procedures are essential for maintaining optimum performance of your espresso machine. The following are procedures to be carried out on a daily basis:

Backflushing:

This process forces water through the inlet tube and drain system. This should be performed on EACH brew group daily.

1. Replace the filter basket with the 'blind' basket, which has no filter holes.
2. Engage the portafilter, then follow the instructions on page 21 to use the auto backflush function.
3. When using an approved espresso industry detergent during backflushing, follow the manufacturer's instructions. It is extremely important to thoroughly rinse the blind filter basket and repeat backflushing several times with clean water to clear the system of any detergent residue. **Failure to rinse after using detergent can cause valve problems and bad flavor.**

Note: NEVER remove the diffuser screen and screw when backflushing. Backflushing without the screen can cause detergent and other unwanted particles to enter the brew system and can lead to valve and flow problems. Remove and clean the screen and screw after backflushing is complete. Do not forget to reinstall.

General Machine Cleaning:

1. Clean the surface of the machine using a soft damp cloth. Avoid using abrasive cleaners or cleansing pads. Take extra care on the mirror finish stainless steel surfaces. A "micro-fiber" towel is recommended to avoid scratches.
2. Make sure the steam wands and tips are free of milk build-up. It is always best to clean the steam wand and tip after each use by purging and wiping with a damp cloth. Approved espresso industry cleaners can be used to dissolve milk build-up. Tips can be removed to soak. Deep cleaning of the wands and tips should be carried out periodically.
3. The drip tray, drip tray grates, and portafilters should be removed and cleaned every day. If you clean the portafilters in the dishwasher, first remove the filter baskets and springs before washing. Do not place wooden handled portafilters in the dishwasher. Wood should be cleaned using wood-safe cleaning procedures.

Wood and Water

Wood accents should be wiped down with a damp rag to clean. Do not soak or soap wood. Never place wood products in the dishwasher! Treat wood with food safe oil or wax quarterly or more often if the surface appears dry.

MAINTENANCE

MAINTENANCE SCHEDULE

Proper and regularly scheduled cleaning and maintenance procedures are CRITICAL for optimum performance of your espresso machine.

Daily

1. Backflush each brew group without detergent throughout the day. Backflush with an espresso industry approved detergent during the final cleaning of the night (or after a busy period) and then again without detergent to rinse.
2. Purge wands before and after each use. Wipe wands and steam tips with a damp cloth after each use. Clean the wands and steam tips with approved espresso industry milk cleaner during the final cleaning of the night.
3. Wipe down the entire machine with a soft cloth.
4. Remove portafilters, baskets and springs, drip tray and grates and clean all thoroughly. These items are all dishwasher safe (with the exception of wooden handled portafilters).
5. Slowly pour a pitcher of hot water down the drain to clear grounds debris and prevent blockage.

Weekly

1. Soak portafilters and the removed filter baskets in an approved espresso industry detergent and water solution. Rinse thoroughly before reassembling and using your portafilters.
2. Carefully remove screens and screws from each brew group using a short handled screwdriver and soak them overnight in a similar solution as the portafilters.

Note: Rinse screens and screws thoroughly before installing and using. Make sure you install the screens before brewing any shots of espresso. Failure to do so may plug the drain lines with coffee grounds. DO NOT overtighten the screw during reassembly.

Monthly

1. Check your water filtration system and make sure the cartridges and filters are changed as needed. In areas of high mineral content, hard water, high particulate count or in very busy locations, the filtration systems will need to be checked more often.

Quarterly - See Page 32 for Recommended 90 Day PM List

1. Change portafilter gaskets and closely inspect diffuser screens and filter baskets, If these items are showing wear, please replace them as soon as possible. Change these items if they show damage or overuse.
2. Briefly inspect the machine for leaks or potential issues. Contact Synesso or your local distributor or service agent to order parts and/or request service.

Annual - Please Refer to Annual PM Checklist on Page 33

Synesso™ recommends that you contact your distributor or service agent for periodic maintenance. The frequency of maintenance visits will depend on a variety of factors including how much use the machine receives, but at least one preventative maintenance visit per year is required. During this yearly service, all body panels must be removed and all connections both electrical and hydraulic must be inspected. Small problems can become large if not caught early.

Quarterly Preventative Maintenance Guide

- **Replace portafilter gaskets**
 - 8.5mm - 1.3441 (standard size)
 - 9.0mm - 1.3430 (for older handles with worn ears)
- ◆ **Inspect and replace group diffuser screens if worn or damaged**
 - Synesso reinforced screen - 1.3292
- **Inspect portafilter baskets for wear or damage. Replace if necessary**
 - 14 gram basket - 1.7000
 - 18 gram basket - 1.7090
 - 21 gram basket - 1.7170
- **Inspect and/or rebuild steam valves if signs of leaking. Clean and lubricate wand pivot ball and pusher face**
 - Rebuild kit - 1.7320
 - Complete valve - 1.4501
- **Remove and clean steam tips**
- **Check flow rate at each brew group. Minimum 2oz in 6-8 seconds**
- **Check that expansion valve does not leak at 9 bar. 11-12 bar is the factory standard setting**
 - Expansion valve - 1.4070
- **Check line and pump pressures**
- **Inspect steam tank vacuum breaker. Replace if signs of leaking**
 - Vacuum breaker - 1.4265
- **Inspect steam tank pressure relief valve (dark spots may indicate leaking). Replace if signs of leaking**
 - Pressure relief valve - 1.4100
- **Depressurize steam and brew systems, check that gauges return to zero. Replace if not accurate**
 - 0-60psi steam gauge - 1.4083
 - 0-300psi brew gauge - 1.3373
- **Remove and inspect level probes. Clean scale if necessary**
 - Upper level probe (fill probe) - 1.4111
 - Lower (safety) probe - 1.4112
- **Inspect drain hose for clogs or leaks**
- **Check steam handles for grit, friction, or contacts. Lubricate and adjust as needed**
- **Test handheld controller for proper operation. All buttons react as normal**

SYNESSO

Annual Warranty Checklist

S Series Machines

Customer Name: _____

Machine Model: _____

Serial Number: _____

To qualify for the Synesso 2 and 5 year warranty, this checklist must be returned to Synesso within 30 days of 1 year in service.

- Replace portafilter gaskets**
 - 8.5mm 1.3441 (standard size)
 - 9.0mm 1.3430 (for older handles with worn ears)
- Replace group diffuser screens**
 - Synesso reinforced screen 1.3292
- Inspect portafilter baskets for wear or damage. Replace if necessary**
 - 14 gram basket 1.7000
 - 18 gram basket 1.7090
 - 21 gram basket 1.7170
- Rebuild or replace steam valves. Clean and lubricate wand pivot ball and pusher face**
 - Rebuild kit 1.7320
 - Complete valve 1.4501
- Remove and clean steam tips**
- Remove side and splash panels, inspect tanks, copper tubes, and all fittings for leaks**
- Inspect and replace all ruby flow restrictors and brew valves**
 - Ruby jet replacement kit (0.6mm) 1.3191
 - Brew valve 1.2460
- Check flow rate at each brew group. 2oz water in 6-8 seconds**
- Test consistency and accuracy of volumetrics across all groups**
- Check that expansion valve does not leak at 9bar. 11-12 bar is the factory standard setting**
 - Expansion valve 1.4070
- Check line and pump pressures**
- Replace steam tank vacuum breaker**
 - Vacuum breaker 1.4265
- Inspect steam tank pressure relief valve (dark spots may indicate leaking). Replace if signs of leaking.**
 - Pressure relief valve 1.4100
- Depressurize steam and brew systems, check that gauges return to zero. Replace if not accurate.**
 - 0-60psi steam gauge 1.4083
 - 0-300psi brew gauge 1.3373
- Remove and inspect level probes. Clean scale build up if necessary**
 - Upper level probe (fill probe) 1.4111
 - Lower (safety) probe 1.4112
- Inspect drain hose for clogs or leaks**
- Check element gaskets for signs of leaking, tighten if needed**
- Test handheld controller for proper operation. All buttons react as normal**
- Test steam tank element set points. Cycle each loop of element**

Authorized Technician Signature and Date _____

FLOWMETER CALIBRATION INSTRUCTIONS

These instructions are to be performed using the flowmeter calibration feature made available with firmware version 2.64. See page 26 for information on accessing this feature in the programming.

WARNING: It is recommended that this calibration be performed while the machine is cool and the heating elements are off. Performing the calibration while the machine is hot can lead to errors in desired accuracy.

Materials Needed:

- Cup (or pitcher, etc.) with at least 250ml capacity and a wide enough mouth to capture water dispensed from brew group
- Slotted screwdriver short enough to fit under group head (might need “stubby” one)
- Graduated cylinder with 250ml capacity and 2ml resolution or better.

WARNING: Some users may prefer to use a scale instead of a graduated cylinder. Note that the density of water varies as a function of temperature. Grams and milliliters are equivalent for water at 4°C (just above freezing.) However, at brew temperatures water density is closer to 0.97g / ml. Therefore, if you weigh some water (in grams) out of a hot brew group and want to calculate its volume (in ml,) you must divide by roughly 0.97.

Calibration Instructions:

1. Clean and backflush the brew groups.
2. Remove the diffuser screens and screws.
3. Ensure the heating element breaker is off.
4. In order to make the starting brew pressures more consistent, run each group briefly without the pump on. This can be done using the BREW VALVES function on the TEMPERATURE DISPLAY screen found in the 2nd level menu (see page 23).
5. In the 2nd level menu, cycle to the FLOWMETER CALIBRATION screen. (see page 26)
6. Position the cup under the 1st brew group
7. Follow the on screen prompts to dispense a test volume of water into the cup. The machine will automatically stop when the test volume of water has been dispensed (approximately 250 ml).
8. Carefully transfer the water from the cup into the graduated cylinder and measure the volume.
9. Enter the measured volume on the screen.
10. Proceed to the next brew group, repeating steps 6-9 until all groups are calibrated.
11. Return to the TEMPERATURE OVERVIEW home screen.

Optional Verification:

Note: the verification step does not utilize the calibration program, but is intended to verify that the calibration was successful.

1. In the first level menu, adjust the volume for program 1 on each group up to 444 TOTAL WATER COUNT.
2. Run program 1 on all of the brew groups for a few seconds to get each group up to pump pressure.
3. Position the cup under the 1st brew group.
4. Run program 1 to dispense 444 ticks worth of water into the cup.
5. Verify with the graduated cylinder that the group has dispensed 100ml of water.
6. Proceed to the next brew group, repeating steps 3-6 until all of the groups are verified.
7. Turn the heating elements back on and reinstall the diffuser screens and screws.

TROUBLESHOOTING GUIDE

This is a basic troubleshooting guide for some of the common issues that operators might encounter when using their machine. For more detailed assistance with technical issues, contact your distributor, local service agent, or Synesso Technical Support.

The machine may be reset by powering off for 10 seconds.

Brewing problems:

The Shot is Pouring Too Slowly:

- Tamp pressure was too firm
- Too much coffee is in the basket
- The grind is too fine
- Diffusion screens are clogged; clean or replace
- Pump pressure is too low. Ensure that it is set between 8-9.5 bar
- Brew jet is clogged; when operating properly, 60ml water should flow out within 8 seconds

The Shot is Pouring Too Quickly:

- Tamp pressure is too light
- Not enough coffee in the basket
- Grind is too coarse
- Portafilter baskets are worn or cracked; replace
- Brew temperature is too cold

Crema is Thin with Large Bubbles and Tastes Astringent:

- Coffee is old
- Grinder burrs are dull
- Brew temperature may be set too low

Diffuser Screen is Loose:

- This is most likely caused by over filling the portafilter basket with coffee. This causes the expanding coffee puck to push against the diffuser and bend the screen-to-screw contact point away from the screw.

No Pump Pressure When Water Flows from the Group:

- Check the programmed preinfusion time. The pump will not activate until the preinfusion time has completed.
- Pump relay may have failed. Have a technician perform further diagnostics.

The Pump Comes On, Gauge Reads Full Pressure, but No Water Comes Out:

- Diffuser screen/screw, or jet is clogged
- Soap residue not fully flushed after cleaning has glued the valve closed (tap the valve body gently).
- Brew solenoid has been sealed shut by dried soap or has failed.

TROUBLESHOOTING GUIDE

Brew Gauge

Brew Pressure Gauge Needle Value Changes Often:

- This is normal. The lowest number (usually 3-5 bar) reflects the incoming line pressure. When brewing the needle reflects brew pressure (8.5-9 bar). When the brew tanks heat, the water expands and the expansion valve relieves the pressure at 11 or 12 Bar.

Brew Gauge Needle Flutters or Vibrates:

- Water is in the gauge or tube.
- Pump is failing
- Gauge is failing

Brew Pressure is Low:

- When brewing on one group and another group is activated, some water will be diverted to the second (or third) group. This will slightly reduce available brew pressure.
- Expansion valve may be set too loose. Check that the pressure in the brew system reaches 10-12 bar while heating from a cold state. If the pressure does not exceed brew pressure, the expansion valve will need to be tightened.
- Check pump to make sure pressure is properly set.
- Water supply hose to the pump is kinked.
- Water filter is plugged. Check and replace if necessary.
- Brew valves are worn and water is being diverted to the discharge (drain). Look for error VMUF0#.

Brew Pressure is High (above 12 bar) While Machine is Idle:

- The expansion valve needs to be adjusted. The valve should be set so that maximum pressure is 11-12 bar.
- The gauge has lost calibration.

No Brew Pressure; Pump/Motor Runs:

- Brew Solenoid is stuck (can be caused by soap residue not fully flushed after cleaning).
- Brew Solenoid has failed.
- The line between the pump and the water supply has collapsed or is kinked.
- The line to the pump is kinked.
- Water filter is plugged. Check and replace if necessary.
- Water supply is inadequate.

TROUBLESHOOTING GUIDE

- Failed pump, needs to be replaced.
- Brew valve may have timed out (error BRBV0#). Turn brew group off to reset.

No Brew Pressure; Pump/Motor is NOT Running

- Pump relay failure. Inspect the relay.
- Pump is locked or has failed.
- Motor has failed.

Brew Temperature

Readout for Brew Water Temperature Varies by a Few Degrees:

- The control must detect a temperature one increment (0.5°F on original machines, or 0.1°F on current machines) above the set point before it sends a signal to turn off the heating element. This will allow the electronics to show a reading just above the set point. The energy from the heating element and the tube for the preheated incoming water are within 1" (25mm) from the location of the temperature probe in the brew tank. The pick up tube for brew water is at the top of the brew group and is in the most temperature stable water in the tank. The readout can show a temperature of a few degrees above your set point, but your brew water is actually at the set point.

Brew Temperature Reads Low (error BRUT0#):

- Be sure to allow 20-40 minutes from the time the machine is powered up as the temperatures need to stabilize. Ambient temperature and airflow can change how quickly the machine reaches stability.
- Make sure the set point has not been changed.
- Check the programming in the handheld controller to ensure the brew elements are ACTIVE.
- Have a technician perform further diagnostics.

Brew Temperature Reads High (error BROTO#):

- Display temperature will climb during brewing as hot water from the steam tank heat exchanger enters the brew tank. This is normal and the water dispensed will be at your set point, not the displayed temperature.
- Make sure the set point has not been changed.
- Have a technician perform further diagnostics.

Electronics

All Tanks Read LOW:

- Check to make sure the element breaker is ON. Tanks will read low until the temperature in them reaches 175° F. Please allow 20-30 minutes to heat up initially.

TROUBLESHOOTING GUIDE

- Have a technician perform further diagnostics.

An Individual Tank Reads LOW:

- Have a technician perform further diagnostics.

An Individual Tank Reads Above the Set Point:

- Have a technician perform further diagnostics.

Handheld Controller Display is Blank:

- If the red power switch is in the ON position and is NOT lit, there is a lack of power to the machine. Check the wall plug and circuit breaker.
- If the red power switch is in the ON position and is lit, check that the lid of the electronics box is tightly secured to the box. There is a safety interlock switch inside the box which interrupts power to the electronics when the lid of the electronics box is loose or removed.
- Have a technician perform further diagnostics.

Shot Timers are Blank; Machine is Powered:

- Have a technician perform further diagnostics.

Shot Timers are Cycling Through All Possible Indicators:

- Shot timer is stuck in test mode. Have a technician inspect the timer board.

Steam Wand

Drip at the Steam Wand Tip:

- A small amount of water will naturally drip as water condenses and accumulates in the wand between uses. Make a habit of purging the steam wand of all accumulated liquids before and directly after steaming a pitcher of milk.
- Steam valve seal is worn. Have a technician perform a steam valve rebuild.
- Steam valve is filled with milk residue. Have a technician inspect and clean the valve.
- Steam actuator is engaging valve in off position. Actuator needs to be adjusted.

Wand is Hard to Move or Sticky:

- Remove wand at the nut, clean and lubricate moving parts with food grade grease

Water Bubbles Out Around Wand Ball Pivot:

- Wand ball o-ring is worn, replace with new Teflon o-ring from steam valve rebuild kit.

Weak Steam Pressure from Wand:

- Steam valve not fully opening, steam handle needs to be adjusted
- Steam tip is clogged. Clear steam tip of residue.
- Steam valve is clogged. Have a technician inspect the valve.

TROUBLESHOOTING GUIDE

- Have a technician perform further diagnostics.

Steam Pressure

Sudden Loss of Steam Pressure:

- Commonly caused from drawing large amounts of hot water while steaming milk or using the tea tap. Allow the machine time to recover pressure. Check steam temperature set point to make sure it's high enough for your application. Watch the steam gauge when the pressure drops; allow the heating elements to heat the incoming cold water. When it reads above 1.1 bar, hot water and steam may be dispensed again.
- Check the wired controller to make sure all temperatures, especially in the steam tank, are close to their set points.
- Check the element breaker to make sure the heating elements are ON.

Steam Pressure is Set for 1.8 bar or Higher:

- The machine can be set for steam pressure at over 2.0 bar but there can be side effects in the brewing process. A small amount of water is preheated in the steam tank for brewing. If the temperature in the steam tank is set very high then this could allow for the preheated brew water to be too hot and cause some erratic brew temperature spikes. There are ways to make this work if it is absolutely necessary to have a very hot steam tank. Contact Synesso Technical Support for more details.

Steam Tank

Steam Tank is Not Filling:

- Check for STFV00, STFP00, and/or LOW H2O errors. Power cycle the machine.
- Check inlet hoses for kinks/pinches. Check filter is not clogged, change if needed.
- Have a technician perform further diagnostics.

Steam Tank is Overfilling:

- Water quality is not in spec. The water level probe requires a low level mineral content in order to detect the water and relay information to the CPU. Do not use deionized water in the machine.
- Debris caught in fill valve. Have a technician inspect the valve.
- Level probes require inspection. Have a technician inspect the level probes.

Steam Has Undesirable Smell; Water from Tank is Discolored and/or Has Debris:

- The tank is contaminated. Have a technician perform a cleaning of the tank.

Steam Valve Stem Seal Leaks:

- Have a technician perform a steam valve rebuild.

TROUBLESHOOTING GUIDE

Hot Water Tap

No Water Flows When the Switch is Pressed:

- Have a technician perform further diagnostics.

Only Cold Water Flows when Switch is On:

- Turn the mix valve clockwise until it stops. This will cut off all cold water flow. If no water flows with the mix valve off, the hot water valve has failed.
- Check the steam pressure gauge reads 1.1 bar or higher. Hot water will not flow without pressure from the tank.

Only Hot Water Flows when Switch is On:

- Check that the cold water mix valve is not fully closed. A fully closed mix valve will only allow steaming water out to the hot water tap. Turn counter-clockwise to open and allow cold water to mix with the hot water.
- Turn the cold water mix valve a full turn and a half counter-clockwise. If the water at the tap is still steaming/sputtering, the cold water valve has failed.

Leaks

Hot Water Tap:

- If the drip is cold water, the water control valve on the cold side of the mix valve is leaking. Have a technician replace the valve.
- If the drip is warm or hot water, the water control valve on the hot side of the mix valve is leaking. Have a technician replace the valve.

Steam Wand:

- See troubleshooting related to steam wand starting on page 38.

Brew Groups:

- A leaking diffuser indicates the brew valve is not sealing properly. Have a technician inspect the valve.
- If water leaks out around the sides of the portafilter when properly engaged and brewing, the portafilter gasket should be cleaned. If the leak continues once the gasket is clean, the gasket should be replaced.

Other Leaks:

- Dirty / brown water under the machine indicates the drain box is clogged or overloaded. Be sure the drain hose has an even, steady slope towards the floor drain. Kinks, dips, or flat runs will slow or stop the flow of waste water from the machine drain.
- A small amount of water may splash between frame panels during a steam wand purge or when rinsing

TROUBLESHOOTING GUIDE

the drip pan. The water will then drip onto the countertop or frame of the machine. This is normal.

- Clean water under the machine indicates an internal leak. Have a technician perform further diagnostics.
- In the case of a large leak in which water is collecting in the machine frame or pooling significantly below the machine, power down and unplug the machine and shut off the main water supply until a technician has repaired the leak.

Vacuum Breaker:

- When the machine is heating from cool and begins to build pressure from zero, it is normal for the vacuum breaker to sputter until the steam tank is near full pressure.
- If sputtering occurs when the steam tank is near or at the set pressure, have a technician replace the vacuum breaker.

General Issues

Beeping Machine:

- Low level alarm probe is not grounding out. Power cycle the machine. Ensure the tank is filling. Check for adequate water flow to the machine. Have a technician perform further diagnostics.

Portafilter Stopping Point is Off

- Under normal circumstances, when the portafilters are fully engaged the handle will face the barista. If the portafilter stopping point is occurring before this point (handle points to the left), check that the standard size 8.5 mm gaskets are being used and that the gasket is seated fully around the diffuser block.
- If the portafilter stopping point is occurring after the normal point (handle points to the right), inspect the “ears” of the portafilter for wear. If brass is showing on the ears, try using the taller 9mm gaskets. Alternately, you can replace the portafilter head.

Pump/Motor is Making an Unusual Sound:

- Make sure the water to the pump is fully on. Check the filters for clogs, change if needed. Check the water lines for kinks.
- Pump may be worn and in need of replacement.

High-Pitched Whistling Noise When Groups are Active:

- Water is leaking out from the brew system. Check for VMUF0# error. Have a technician inspect the expansion valve and brew valve discharge for unusual flow.