

OptiPure

Snapshot

The SX2-21 is a dual-housing water treatment system with drop-in 10" cartridges that reduces sediment down to 0.5 microns and reduces chlorine, taste & odor at a flow rate of 1.5 gpm for 15,000-gallons. This system includes ScaleX2[®], a chemical-free scale inhibition technology that utilizes Template-Induced Crystallization to effectively inhibit the formation of calcium-carbonate scale.

System Benefits

- ScaleX2[®] protects boilers, steam generators, and coffee equipment against the formation and accumulation of scale.
- Reduces maintenance frequency and cost, and extends equipment life.
- Gradient-density sediment filtration protects against dirt, rust and other debris down to 0.5 microns.
- High-capacity activated-carbon filtration makes water taste great and protects equipment against corrosive chlorine.
- Sturdy, powder-coated mounting bracket and full-flow inlet shut-off valve simplify installation.
- Inlet shut-off and depressurization valves make filter replacement quick and simple.
- Minimizes waste by only replacing drop-in cartridge and reusing filter sump.
- NSF Certified under Standard 42.

Model: **SX2-21**
Part #: 160-00350

ITEM #: _____ QTY: _____
JOB NAME/NUMBER _____



Application

STEAM & COMBI OVENS - boilers or steam generators up to 1.5 gpm. Not recommended for flash type (boilerless) combi ovens.

COFFEE BREWERS - Single or combination applications up to 1.5 gpm.

Installation Tips

- Feed-water connection to system should be COLD only.
- Do not exceed system specifications for temperature and pressure.
- Allow 3" clearance below system for filter housing removal and cartridge replacement.
- Connect filtered water line to ice- and steam-production connections only. Do not use for condenser water.
- Detailed installation, operation and maintenance manual included with each system.
- No activation procedure or flushing required for system to perform as specified.

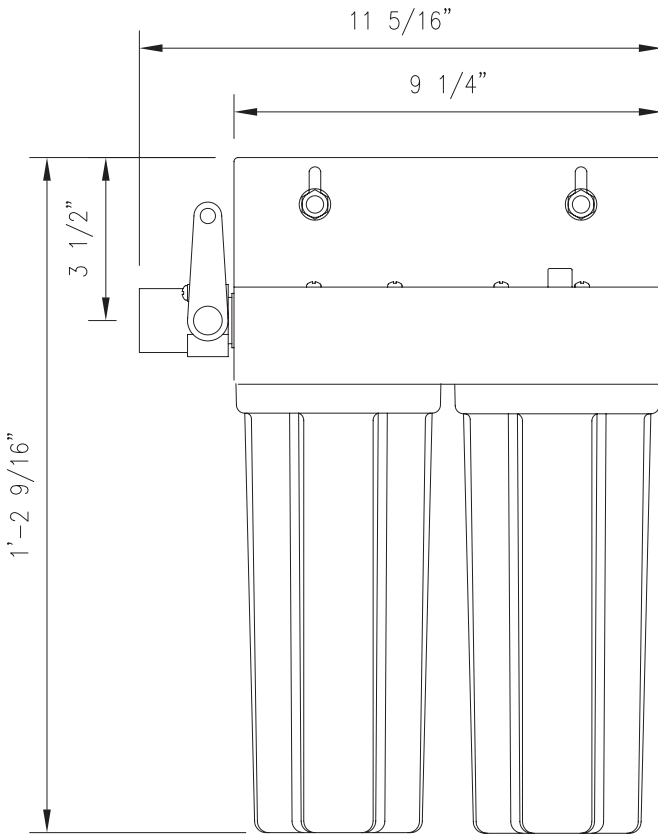

System Tested and Certified by NSF International against NSF/ANSI Standard 42 Aesthetic Effects - Particulate Reduction (Class I) and the reduction of Chlorine, Taste and Odor.



WARNING:
Cancer and Reproductive Harm -
www.P65Warnings.ca.gov.

► Warranty

All system components and assembly except for filter cartridges, separation membranes, permeate pumps, electric motors, diaphragm pumps, and rotary vane pumps shall be warranted against defects in workmanship for a period of 60 months from the date of original shipment. For complete warranty information, contact OptiPure customer service or go to www.optipurewater.com.

Dealer/Distributor Info:

► Specifications

System	
Dimensions (Height x Width x Depth, Inches)	14.6"h x 11.3" w x 5.8"d
Connection - Inlet & Outlet	1/2" FNPT
Operating Pressure Range	10 - 125 psi (0.7 - 8.6 bar)
Inlet Water Temperature Range	35° - 100°F (2° - 38°C)
Shipping Weight	12 lbs.
Performance	
Chlorine, Taste and Odor Reduction Capacity	15,000 gals. (56,775 L)
Service Flow Rate	1.5 gpm (5.7 lpm)
Sediment Reduction	0.5 microns (nominal)
Scale Inhibitor	ScaleX2®

► Replacement Cartridge(s)

Model	Part Number	Qty
CTO-10	252-20110	1
SCLX2-1	252-60205	1
SX21RK*	252-60110	1

*Replacement Cartridge Kit includes one of each cartridge.

► Options

Model	Description	Part Number
Flush Valve Kit	Flush Valve Kit	160-52910

It is recommended that pre/post-filters and mineral addition cartridges are changed every 6 months, when capacity is reached or when feedwater pressure or flow becomes inadequate.

Membrane life varies depending on feedwater conditions and pre-filter maintenance. It is 12-18 months under typical conditions, but it can be as long as 3-5 years.

This product is for commercial use only and must be installed and maintained according to manufacturer's guidelines.

Do not use on water that is microbiologically unsafe or of unknown quality without adequate disinfection before or after the system.

OptiPure, A Division of Aquion, Inc.

101 S. Gary Ave., Suite A
Roselle, IL 60172

p: 972.881.9797 e: info@optipure.net
www.optipurewater.com