

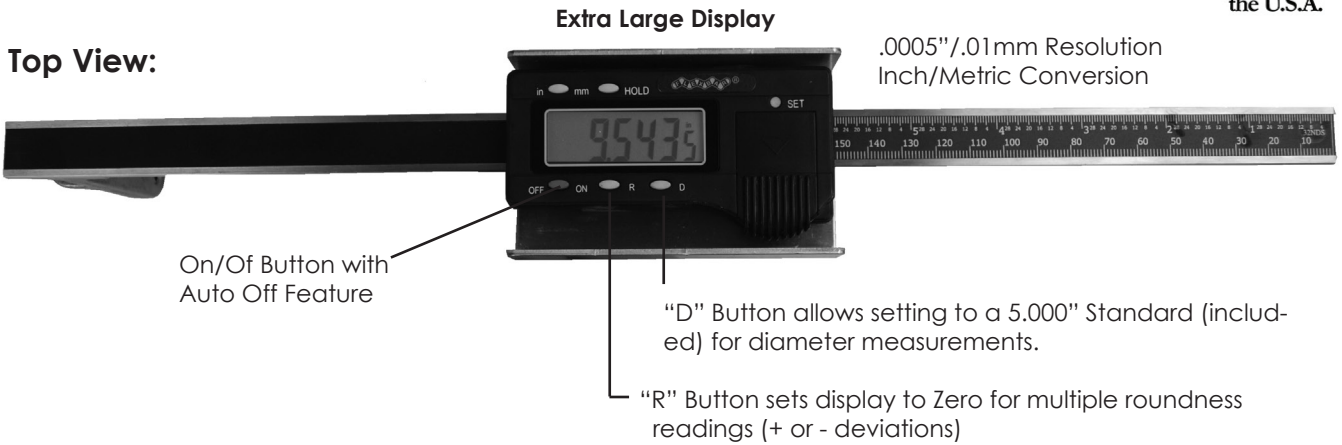

# FLEXBAR LARGE I.D. MEASUREMENT CALIPER

A Quick & Easy Tool For Measuring Internal Diameters of Large Pipes, Drums and Other Dimensions Ranging from 5" (125mm) to 15" (375mm)  
Ideal for determining Out-of-Round Conditions



**Side View:**

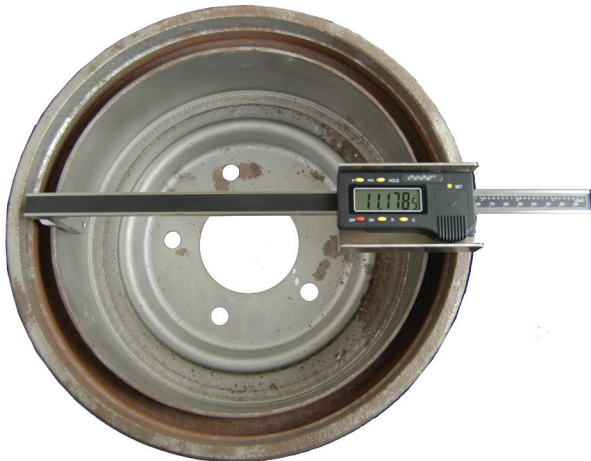
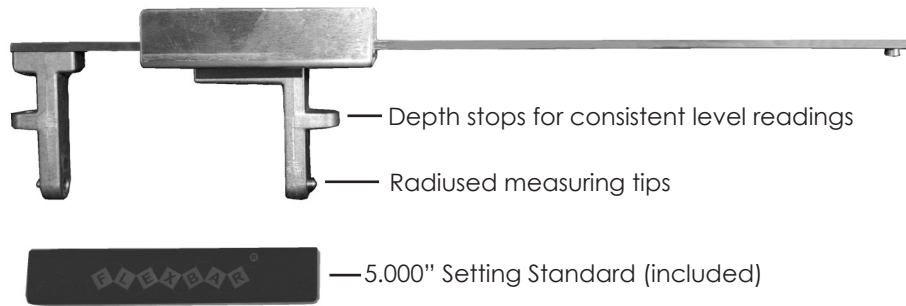

Shown Above: Internal Drum Diameter Measurement



Shown Above: No. 70062 Kit Complete

**MODEL NO. DESCRIPTION**

**70062**

Flexbar Large I.D. Measurement Caliper Complete with 5.000" Setting Standard and Molded Hard Plastic Carrying Case

**15814**

Replacement Battery, 3V type CR2032