

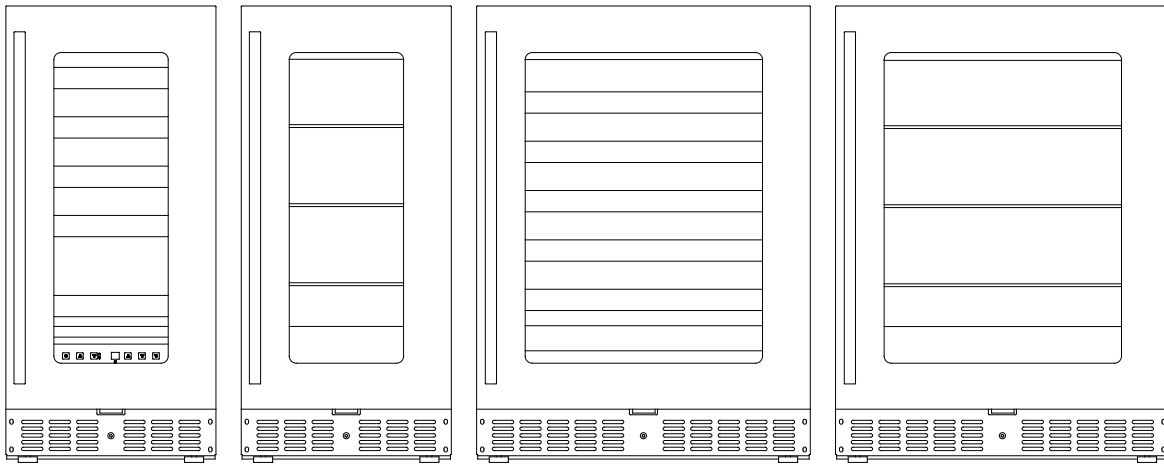

# WINE and BEVERAGE COOLER



## MODELS:

### *Beverage Coolers:*

ASDG1521

ASDG2411

AL57GPNR

### *Wine Coolers:*

ASDW1522

ASDW2412

## *User Manual*

BEFORE USE, PLEASE READ AND FOLLOW ALL SAFETY RULES AND OPERATING INSTRUCTIONS.

Write Serial Nos. (on lower left corner of inside cabinet) here:

\_\_\_\_\_

Felix Storch, Inc.  
An ISO 9001:2015 registered company  
770 Garrison Ave  
Bronx, New York 10474  
[www.summitappliance.com](http://www.summitappliance.com)

# TABLE OF CONTENTS

<b>Appliance Safety</b>	<b>3</b>
<b>Important Safeguards</b>	<b>3-4</b>
<b>Location of Parts</b>	<b>5-7</b>
<b>Installation Instructions</b>	<b>8-13</b>
<i>Before Using your Appliance</i>	8
<i>Installation of your Appliance</i>	8-10
<i>Electrical Connection</i>	10
<i>Reversing the Door Swing of your Appliance</i>	11
<i>Adjusting the Kick Plate</i>	11-12
<i>Installing the Stainless Steel Handle</i>	12
<i>Full Overlay Panel Installation Instructions</i>	12-13
<b>Operating your Appliance</b>	<b>14-19</b>
<i>Recommended Temperature Setting for Wine Cellars</i>	14
<i>Control Panel</i>	14-15
<i>Settings Mode</i>	15-16
<i>Interior Light</i>	16
<i>Sabbath Mode</i>	16
<i>Temperature Memory Function</i>	16
<i>Temperature Alarm/Door Alarm</i>	17
<i>Dynamic Cooling and Silent Mode</i>	17
<i>Door Lock</i>	17
<i>Shelves</i>	17-18
<i>Defrosting</i>	18
<i>Storage</i>	19
<b>Care and Maintenance</b>	<b>20</b>
<i>Cleaning your Appliance</i>	20
<i>Power Failure</i>	20
<i>Vacations</i>	20
<i>Moving your Appliance</i>	20
<i>Energy-Saving Tips</i>	20
<b>Troubleshooting</b>	<b>21-22</b>
<b>Limited Warranty</b>	<b>24</b>

# APPLIANCE SAFETY

Your safety and the safety of others are very important.

We have provided many important safety messages in this manual and on your appliance. Always read and obey all safety messages.



This is the Safety Alert Symbol. The symbol alerts you to potential hazards that can kill or injure you and others. All safety messages will follow the Safety Alert Symbol and either the words "DANGER" or "WARNING".



DANGER means that failure to heed this safety statement may result in severe personal injury or death.



WARNING means that failure to heed this safety statement may result in extensive product damage, serious personal injury, or death.

All safety messages will alert you about the potential hazard, tell you how to reduce the chance of injury, and let you know what can happen if the instructions are not followed.

---

## IMPORTANT SAFEGUARDS



Before the appliance is used, it must be properly positioned and installed as described in this manual, so read the manual carefully. To reduce the risk of fire, electrical shock or injury when using the appliance, follow basic precautions, including the following:



- Plug into a grounded 3-prong outlet, do not remove grounding prong, do not use an adapter, and do not use an extension cord.
- Replace all panels before operating.
- It is recommended that a separate circuit serving only your appliance be provided. Use receptacles that cannot be turned off by a switch or pull chain.
- Never clean appliance parts with flammable fluids. These fumes can create a fire hazard or explosion. And do not store or use gasoline or other flammable vapors and liquids in the vicinity of this or any other appliance. The fumes can create a fire hazard or explosion.
- Do not connect or disconnect the electric plug when your hands are wet.
- Unplug the appliance or disconnect power before cleaning or servicing. Failure to do so can result in electrical shock or death.
- Do not attempt to repair or replace any part of your appliance unless it is specifically recommended in this manual. All other servicing should be referred to a qualified technician.
- This appliance is CFC- and HFC-free and contains small quantities of Isobutane (R600a) which is environmentally friendly, but flammable. It does not damage the ozone layer, nor does it increase the greenhouse effect. Care must be taken during transportation and setting up of the appliance that no parts of the cooling system are damaged. Leaking coolant can ignite and may damage the eyes.
- In the event of any damage:
  - Avoid open flames and anything which creates a spark,
  - Disconnect from the power supply,
  - Air the room in which the appliance is located for several minutes and
  - Contact the Service Department for advice.
- The more coolant there is in an appliance, the larger the room it should be installed in. In the event of a leakage, if the appliance is in a small room, there is the danger of combustible gases building up.

For every ounce of coolant at least 325 cubic feet of room space is required. The amount of coolant in the appliance is stated on the data plate inside the appliance. It is hazardous for anyone other than an Authorized Service Person to carry out servicing or repairs to this appliance.

- Take serious care when handling, moving and using the appliance to avoid either damaging the refrigerant tubing or increasing the risk of a leak.
- Replacing component parts and servicing shall be done by factory authorized service personnel, so as to minimize the risk of possible ignition due to incorrect parts or improper service.

## **WARNING**

FOLLOW WARNING CALLOUTS BELOW ONLY WHEN APPLICABLE TO YOUR MODEL

- Use two or more people to move and install appliance. Failure to do so can result in back or other injury.
- To ensure proper ventilation for your appliance, the front of the unit must be completely unobstructed. Choose a well-ventilated area with temperatures above 72°F (23°C) and below 78°F (26°C).
- The appliance should not be located next to ovens, grills or other sources of high heat.
- The appliance must be installed with all electrical, water and drain connections in accordance with state and local codes. A standard electrical supply (115 V AC only, 60 Hz), properly grounded in accordance with the National Electrical Code and local codes and ordinances, is required.
- Do not kink or pinch the power supply cord of the appliance.
- The size of the fuse (or circuit breaker) should be 15 amperes.
- It is important that the appliance be leveled in order to work properly. You may need to make several adjustments to level it.
- All installations must be in accordance with local plumbing code requirements.
- Make certain that the pipes are not pinched, kinked or damaged during installation.
- Check for leaks after connection.
- Never allow children to operate, play with or crawl inside the appliance.
- Do not use solvent-based cleaning agents or abrasives on the interior. These cleaners may damage or discolor the interior.
- Use this appliance only for its intended purpose as described in this *Instruction Manual*.
- Keep fingers out of the “pinch point” areas. Clearances between the door and cabinet are necessarily small. Be careful closing the door when children are in the area.

## **DANGER**

***Risk of child entrapment!***

Child entrapment and suffocation are not problems of the past. Junked or abandoned appliances are still dangerous, even if they will “just sit for a few days”.

*Before discarding your old refrigerator:*

*Take off the doors*

*Leave the shelves in place so that children may not easily climb inside.*

**- SAVE THESE INSTRUCTIONS -**

# LOCATION OF PARTS

## Model ASDW1522

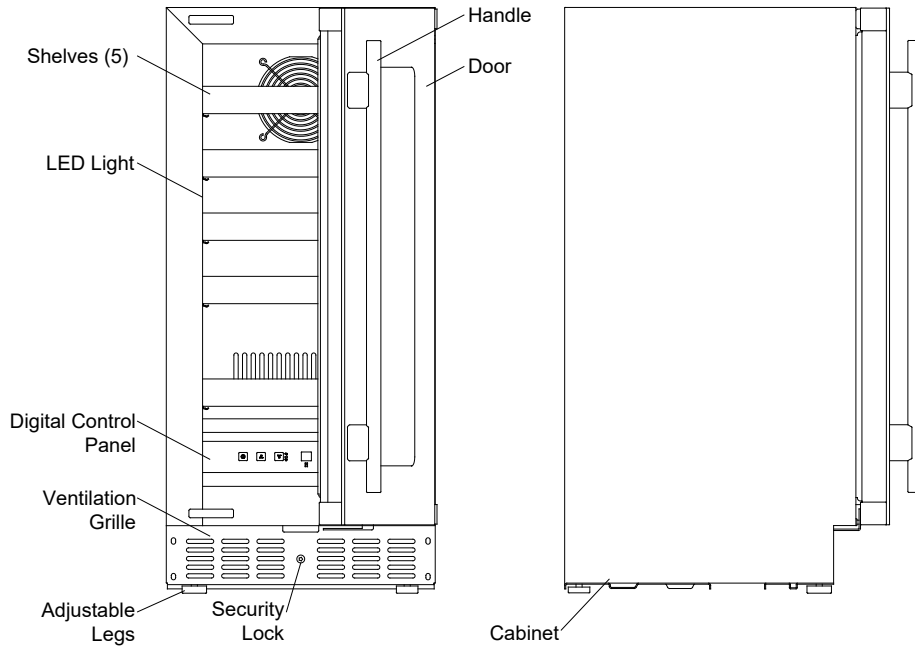

## Model ASDW2412

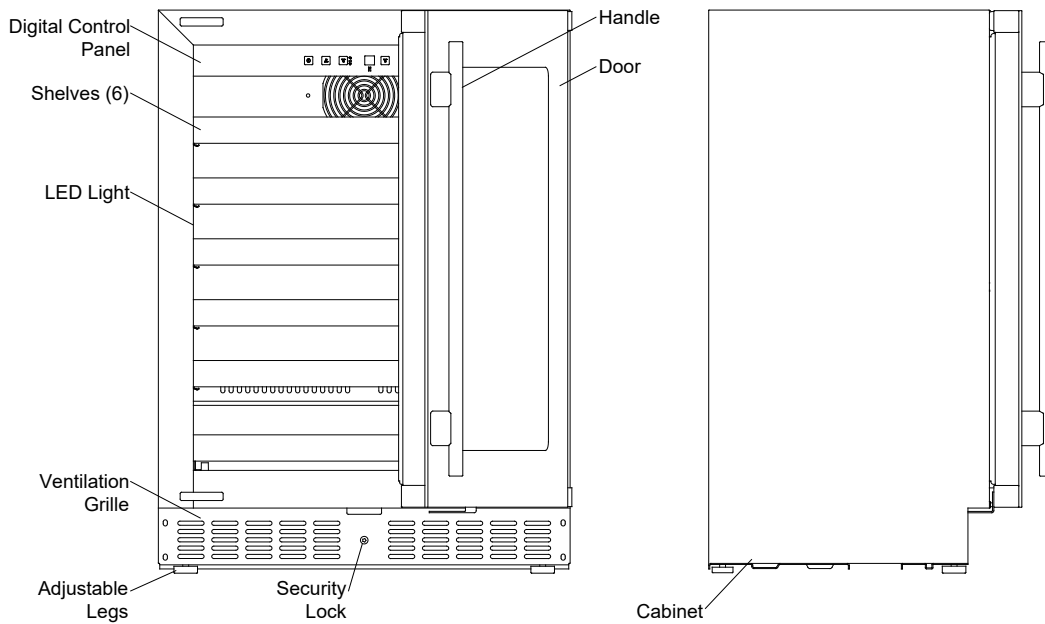

## Model ASDG1521

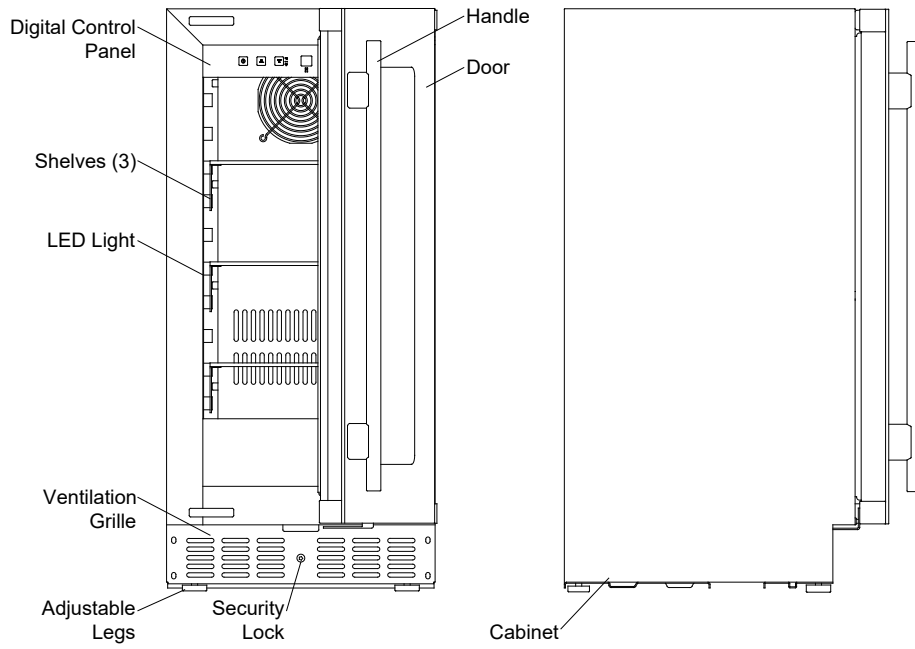

## Model ASDG2411

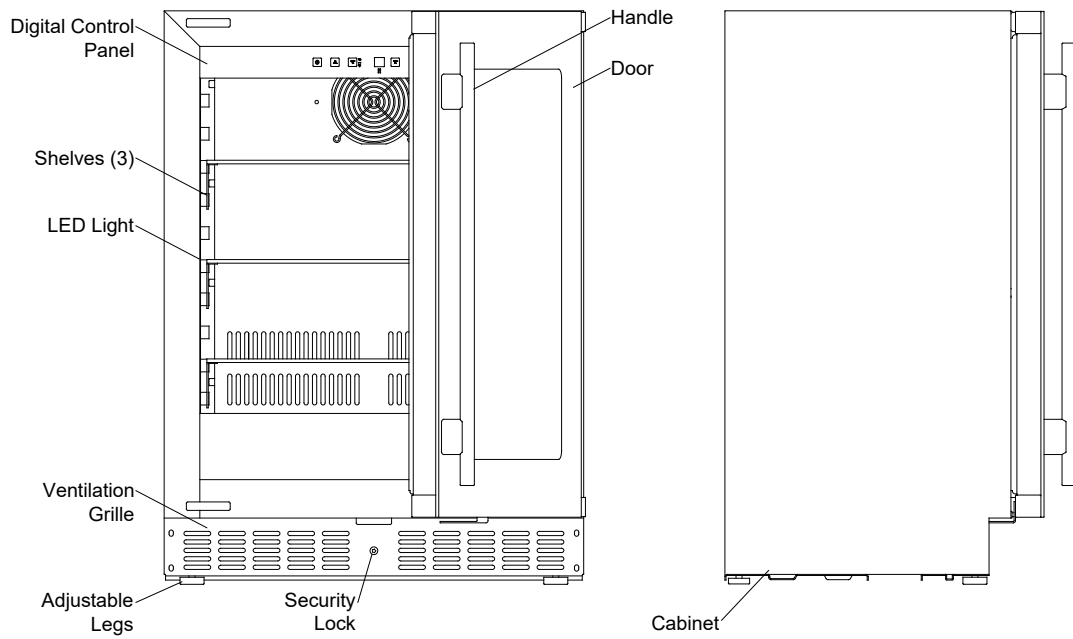

**Model AL57GPNR**

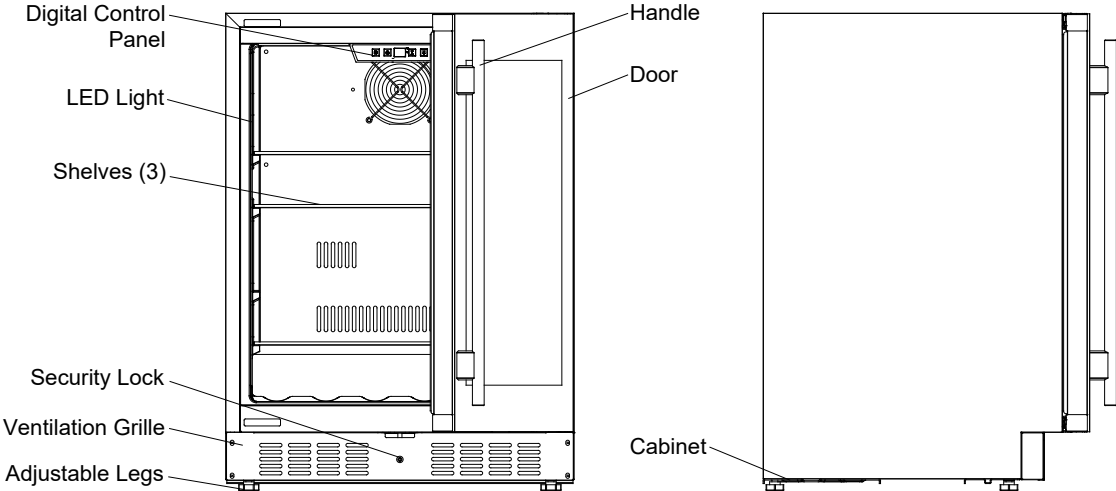

# INSTALLATION INSTRUCTIONS

## Before Using your Appliance

- Remove the exterior and interior packing.

*CAUTION: After unpacking you MUST allow this appliance to stand upright for at least 2 hours to allow the lubricant and refrigerant to drain back into the compressor and stabilize. Failure to do so may adversely affect performance and the lifetime of this unit.*

- Clean the interior surface with lukewarm water using a soft cloth.
- Install the handle on the door. (See Installing the Stainless Steel Handle.)

## Installation of your Appliance

*CAUTION: This appliance is designed for storing and cooling beverages and drinks. Do not store perishable food, medicine or other medical products.*

- The appliance is designed for built-in, recessed or free-standing installation for indoor use only.

**NOTE:** Do not store or install the appliance outdoors.

- Place your appliance on a floor that is strong enough to support it when it is fully loaded. To level the unit, adjust the front leveling legs.
- For freestanding installation, 5" (127mm) of space at the back and sides of the unit and 4" (102mm) at the top are suggested, which allows the proper air circulation to cool the compressor and condenser for energy saving. Even for built-in installation, it is better to keep at least ¼" (5mm) of space on each side, 2" (50mm) at the back and ⅛" (3mm) at the top to ensure proper service access and ventilation. And the air vent at the front of the appliance must never be covered or blocked in any way.

*CAUTION: Make sure that the socket and ON/OFF switch are easily accessible after the appliance has been installed.*

- Avoid locating the unit in moist areas.
- Plug the appliance into an exclusive, properly grounded wall outlet. Do not under any circumstances cut or remove the third (ground) prong from the power cord. Any questions concerning power and/or grounding should be directed toward a certified electrician or an authorized service center.

**NOTE:** It is recommended that you do not install the appliance near an oven, radiator, or other heating sources. Direct sunlight may affect the acrylic coating and heat sources may increase electrical consumption. Do not install in a location where the temperature will fall below 60°F (16°C). For best performance, do not install the appliance behind a cabinet door or block the base grille.



### **Built-in Under-counter Instructions**

During installation, make sure the front ventilation grille is not blocked. The unit is designed to fit under countertops, using the height-adjustable ventilation grille to ensure that the feet are concealed from the front view.

If the fully integrated unit is to be installed to fit a kitchen plinth, make sure that the ventilation gaps in the plinth are at least 300cm<sup>2</sup> (46.5in<sup>2</sup>) and remove the ventilation grilles, so that warm air can disperse unhindered. Otherwise, the appliance will work harder, resulting in an increase in electricity consumption.

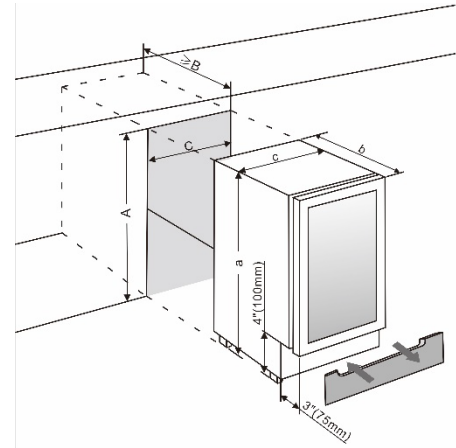

**NOTE:** When inserting the appliance into the installation space, make sure that the main cable does not get trapped.

Model No.	a (Inch/mm)	b (Inch/mm)	c (Inch/mm)	A (Inch/mm)	B (Inch/mm)	C (Inch/mm)
AL57GPNR	32" / 813	22 <sup>3</sup> / <sub>4</sub> " / 575	23 <sup>1</sup> / <sub>2</sub> " / 596	32 <sup>1</sup> / <sub>8</sub> " / 816	22 <sup>3</sup> / <sub>4</sub> " / 575	23 <sup>5</sup> / <sub>8</sub> " / 600
ASDW1522	32" / 813	18" / 455	14 <sup>7</sup> / <sub>8</sub> " / 377	32 <sup>1</sup> / <sub>8</sub> " / 816	18" / 455	15" / 381
ASDW2412	32" / 813	18" / 455	23 <sup>1</sup> / <sub>2</sub> " / 596	32 <sup>1</sup> / <sub>8</sub> " / 816	18" / 455	23 <sup>5</sup> / <sub>8</sub> " / 600

**NOTE:**

1. Model ASDG1521 has the same size as ASDW1522.
2. Model ASDG2411 has the same size as ASDW2412.

### **Anti-tip Bracket Installation**

To reduce the risk of the unit tipping over via abnormal usage or improper loading, the appliance must be secured by properly installing the anti-tip device packed with the appliance.

1. Place the anti-tip bracket on the floor as shown in the figure. An anti-tip bracket must be installed on the left side.
2. Mark the locations of the 4 holes of the anti-tip bracket on the floor.
3. Use a 5/16" masonry drill bit and insert plastic anchors.
4. Secure the bracket to the floor using screws.
5. Slide the appliance into position and make sure the leg is inserted into the anti-tip bracket.

**NOTE:** If the unit is relocated, the bracket must be removed and installed at the new location.

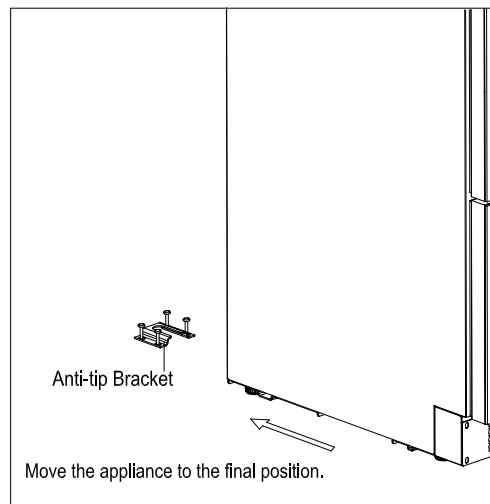
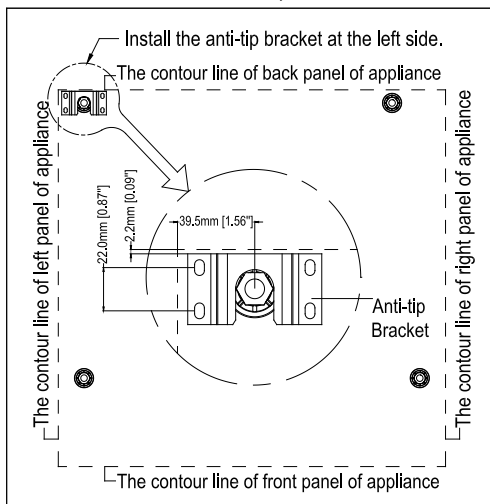

### **Securing the Appliance**

Pop out the cover cap on the opposite side of the hinge and secure the appliance into the space by tightening the screws through the attachment bracket if the unit is provided with an attachment bracket.

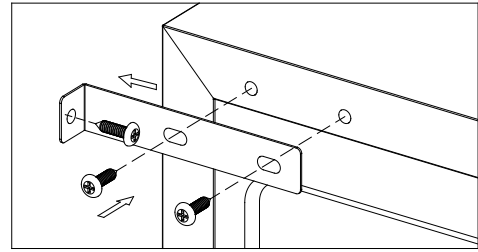

### **Electrical Connection**



#### **WARNING**

Improper use of the grounded plug can result in the risk of electrical shock. If the power cord is damaged, have it replaced by a qualified electrician or an authorized service center.

This appliance should be properly grounded for your safety. The power cord of this appliance is equipped with a three-prong plug which mates with standard three-prong wall outlets to minimize the possibility of electrical shock.

Do not under any circumstances cut or remove the third (grounding) prong from the power cord supplied. For personal safety, this appliance must be properly grounded.

This appliance requires a standard 115/120 Volt AC ~60Hz three-prong grounded electrical outlet. Have the wall outlet and circuit checked by a qualified electrician to make sure the outlet is properly grounded. When a standard 2-prong wall outlet is encountered, it is your responsibility and obligation to have it replaced with a properly grounded 3-prong wall outlet.

To prevent accidental injury, the cord should be secured behind the appliance and not left exposed or dangling.

The appliance should always be plugged into its own individual electrical outlet which has a voltage rating that matches the rating label on the appliance. This provides the best performance and also prevents overloading house wiring circuits that could cause a fire hazard from overheating. Never unplug the appliance by pulling on the power cord. Always grip the plug firmly and pull it straight out from the receptacle. Repair or replace immediately all power cords that have become frayed or otherwise damaged. Do not use a cord that shows cracks or abrasion damage along its length or at either end. When moving the appliance, be careful not to damage the power cord.

### **Extension Cord**

Because of potential safety hazards under certain conditions, it is strongly recommended that you do not use an extension cord with this appliance. However, if you must use an extension cord it is absolutely necessary that it be a UL/CUL-Listed, 3-wire grounding type appliance extension cord that has a grounding type plug and outlet and that the electrical rating of the cord be 115 volts and at least 10 amperes.

## Reversing the Door Swing of your Appliance

This unit has the capability of the door opening from either the left or right side. The unit is delivered to you with the door opening from the left side. Should you desire to reverse the opening direction, please follow the reversal instructions shown on the following page.

**NOTE:** All parts removed must be saved to allow the door swing to be reversed.

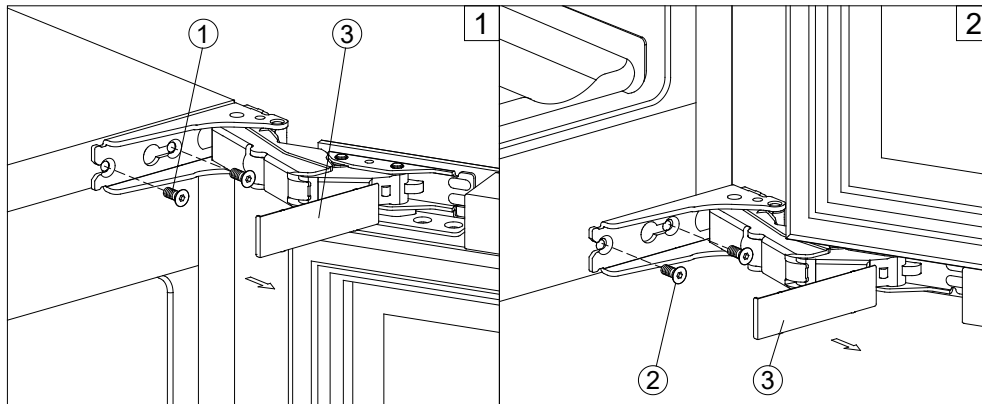

### **WARNING**

Use extreme caution with the articulated hinges. The hinge is self-closing and many pinch points exist prior to built-in installation.

1. Remove the cover caps (3) and then remove the glass door by unscrewing the four screws (1) and (2). Be careful to hold the glass door firmly after removing the screws and place it on a padded surface to avoid the risk of damage.
2. Pop out the cover caps on the left side of the cabinet and use them to cover the screw holes on the right-hand side.
3. Rotate the glass door 180° and refit the glass door to the opposite side. Then screw and tighten it after the door is leveled.

## Adjusting the Kick Plate

The pre-fitted kick-plate of the appliance includes an adjustable kick-plate section that is initially seated behind the upper section. In order to adjust the kick-plate height, follow the instructions below:

1. Remove the screws (1) from both the top left- and top right-hand sides of the kick-plate.
2. Loosen or remove the screws (2) from both the bottom left- and bottom right-hand sides of the kick-plate. Failure to loosen the bottom screws sufficiently may cause damage to the lower trim when adjusting it.
3. Carefully guide the lower trim down until the desired height is achieved.
4. Reinsert screws and tighten them.

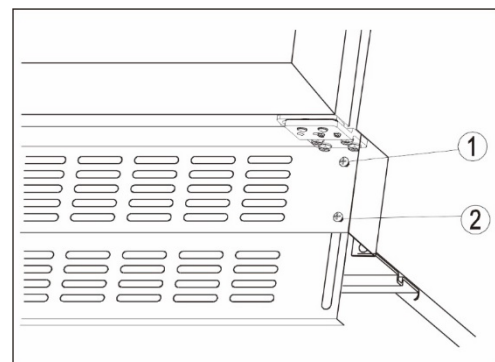

## Installing a Stainless Steel Handle

This appliance includes a stainless steel handle that is not required to operate the unit. To install the handle, follow the instructions below:

Locate the handle (1) over the mounting stub (3) of the door and using the supplied Allen key, tighten the securing grub screws (2) to fix the handle.

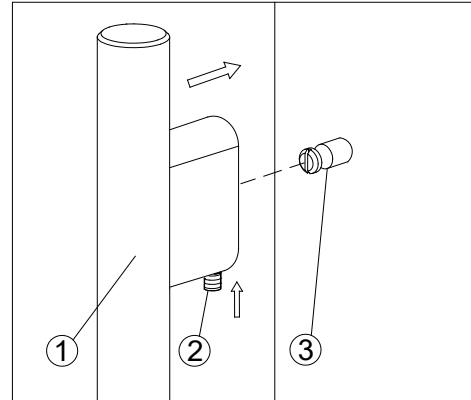

## Full Overlay Panel Installation Instructions

These models are designed to have a field-installed overlay panel. The overlay panel covers the stainless steel to give a built-in appearance. The overlay panel and appropriate hardware are not included with the unit and the end user will need to complete the process themselves. Please follow the instructions below for installation:

### Door Panel Preparation

Prepare the overlay panel to the dimensions shown below. Then attach the handle to the overlay panel by using the flat head screws and drive the screws flush with the panel.

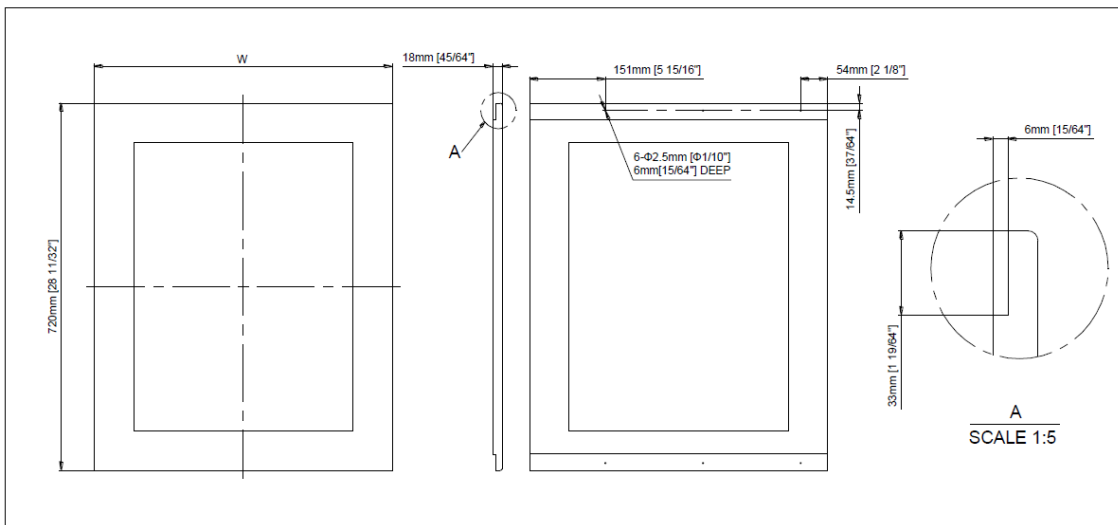

### NOTE:

1. For models **ASDG1521** and **ASDW1522** the width is 14 $\frac{3}{4}$ " (375mm); for models **ASDG2411**, **ASDW2412** and **AL57GPNR**, it is 23.4" (595mm).
2. Weight of the overlay panel should not exceed 15.4 lbs (7kg).
3. It is important to ensure that all drilled holes are drilled to the correct depth to avoid splits in the wood when the hardware is installed.
4. Drill the handle installation holes in the overlay panel according to the handle you are planning to use. If reusing the handles that came with the unit, drill two holes with a distance of 490mm and a diameter of 5mm in the overlay panel.

### **Door Panel Installation**

1. Attach the two provided mounting brackets (2) to the prepared wood overlay panel (3) by using 6 wood screws ST4x10 Type AB Philips (1). (Fig. 1)
2. Gently slide the overlay panel onto the glass door (4). (Fig. 2)
3. Affix the wood overlay panel (3) to the glass door by using 4 ST4x10 Type AB Philips screws (5). (Fig. 3)

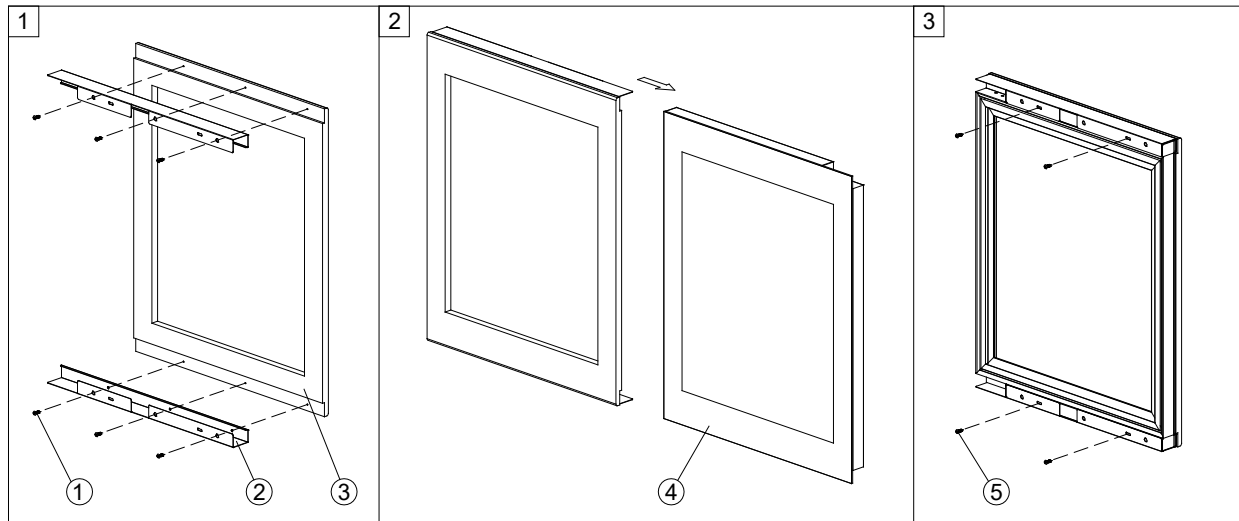

# OPERATING YOUR APPLIANCE

It is recommended that you install the appliance in a place where the ambient temperature is between 72° and 78°F (23° to 26°C). If the ambient temperature is above or below the recommended temperatures, the performance of the unit may be affected. For example, placing your unit in extremely cold or hot conditions may cause interior temperatures to fluctuate. The expected temperature setting may not be reached.



## Recommended Temperature Settings for Wine Cellars

Conservation	49 ~ 57°F	10 ~ 14°C
Red Wines	58 ~ 72°F	15 ~ 22°C
Dry/White Wines	48 ~ 57°F	9 ~ 14°C
Rosé Wines	49 ~ 51°F	10 ~ 11°C
Sparkling Wines	41 ~ 47°F	5 ~ 8°C

## Control Panel



### ON/OFF Power

To turn the appliance off, press and hold the  key for 5 seconds until the temperature display turns off. To turn the appliance on, press and hold the  key for 1 second until the temperature display lights up.

### Light

To turn the interior light on/off, lightly touch and hold the  key for 5 seconds. The interior light indicator will light up or turn off to confirm the selection. The interior light indicator is the dot at the bottom right of the display.

### UP +

Used to increase (warm) the set temperature by 1°F / 1°C.

### DOWN -

Used to decrease (cool) the set temperature by 1°F/1°C.

### Light Indicator / Multi-key Function

The interior light indicator is the dot at the bottom right of the display. The interior light indicator will light up in showcase mode.

The interior light indicator will flash when the multi-key function is selected. To perform the multi-key function, lightly touch and hold the first key, then touch the rest key for at least 5 seconds and then release all the keys.

### **Setting the Temperature Control**

- You can set the temperature by touching the **UP** and **DOWN** symbols. When you push the two buttons at the same time, the LED readout will show the original temperature set previously. (The temperature preset at the factory is 54°F or 12°C for the wine cooler and 38°F or 3°C for the beverage cooler.)
- The temperature you are setting will increase by one degree each time you touch the **Up** symbol, and will decrease by one degree each time you touch the **DOWN** symbol.
- The range of the temperature control is from 41°F/5°C to 68°F/20°C for wine cooler and from 36°F/2°C to 43°F/6°C for beverage cooler.
- To view the set temperature at any time, touch the **UP** or **DOWN** symbol. The set temperature will flash in the display window for 5 seconds. After 5 seconds, the temperature inside the unit will reappear in the display window.

### **Settings Mode**

Certain settings on the wine cabinet can only be selected in settings mode.

Touch and hold the **UP** key for 5 seconds to enter and leave Settings mode. The appliance will leave Settings mode automatically after approximately one minute.

### **°F/°C Selection**

1. Lightly touch and hold the **UP** key for 5 seconds to enter Settings mode.
2. Use **the UP** and **DOWN** keys to select the temperature display setting in Fahrenheit or Celsius degrees.
3. Touch and hold the **UP** key for 5 seconds to confirm the selection.

### **Display Brightness**

1. Lightly touch and hold the **UP** key for 5 seconds to enter Settings mode and then touch the **POWER** key once.
2. Use **the UP** and **DOWN** keys to select the brightness of the display when the door is close. When the door is open, the display brightness returns to its normal level.
  - d0: off
  - d1: dimmest setting (default)
  - d2: medium setting
  - d3: brightest setting
3. Touch and hold the **UP** key for 5 seconds to confirm the selection.

### **Interior Lighting Brightness**

1. Lightly touch and hold the **UP** key for 5 seconds to enter Settings mode and then touch the **POWER** key twice.
2. Use the **UP** and **DOWN** keys to select the brightness of the interior lighting when the door is closed. When the door is open, the interior lighting returns to its normal level.
  - L0: off when the door is closed or open.
  - L1: dimmest setting
  - L2: medium setting
  - L3: brightest setting (default)
3. Touch and hold the **UP** key for 5 seconds to confirm the selection.

### **Fan Mode**

1. Lightly touch and hold the **UP** key for 5 seconds to enter Settings mode and then touch the **POWER** key three (3) times.
2. Use the **UP** and **DOWN** keys to select the fan mode.
  - F0: Silent mode - Energy saving mode (default)
  - F1: DynaClima mode - half time
  - F2: DynaClima mode - full time
3. Touch and hold the **UP** key for 5 seconds to confirm the selection.

### **Audible Tones**

1. Lightly touch and hold the **UP** key for 5 seconds to enter Settings mode and then touch the **POWER** key four (4) times.
2. Use the **UP** and **DOWN** keys to select the audible tones.
  - S0: sensor tone ON, alarm tone OFF
  - S1: sensor tone ON, alarm tone ON (default)
  - S2: sensor tone OFF, alarm tone OFF
  - S3: sensor tone OFF, alarm tone ON
3. Touch and hold the **UP** key for 5 seconds to confirm the selection.

### **Interior Light**

The interior light makes it easy to view your wine labels and enhances the display of your collection. Touching and holding the **LIGHT** key for 5 seconds allows you to toggle between 2 modes of operation for the internal lights: functional (default) mode and showcase mode. If you are in functional (default) mode (also called energy-saving mode), the lights will turn on only when the door is open. If you are in showcase mode, the lights will be on whether or not the door is open.

The unit is equipped with LED-type lights, and they are designed for extremely long life. Thanks to LED lighting, the wine will not be adversely affected by heat or UV light. But they are not user serviceable. To change them please contact the service department.

**NOTE:** Please use only the same type of LED light fittings originally provided by the manufacturer.

### **Sabbath Mode**

Sabbath mode is available for the observance of certain religious holidays. This mode turns off the displays, interior light, and audible alarms and prevents them from turning on again. Normal cooling operations will still take place.

To initiate Sabbath mode, press the **POWER** and **LIGHT** keys at the same time for at least 5 seconds. The displays and interior lights will go out to confirm the Sabbath mode is ON.

Sabbath mode can be canceled by repeating the above process. The Sabbath mode will automatically turn off after 96 hours.

### **Temperature Memory Function**

In the event of a power interruption (power surge, breaker switch, etc.), the unit will remember the previous temperature settings, and when the power is recovered, the cabinet temperature will return to the same set temperature as before power was lost.



## Temperature Alarm/Door Alarm

- An audible alarm sounds if the storage temperature is not cold enough. The temperature display flashes at the same time.
- The cause of the temperature being too high may be:
  - Warm items were placed inside
  - Too much warm ambient air flowed in when rearranging and removing contents
  - Power failure for some time
  - The appliance is faulty.
- The audible alarm is automatically silenced, and the temperature display stops flashing when the temperature is sufficiently cold again.
- If the door has been left open for more than 60 seconds, the alarm will sound. Pressing the any key once will switch off the audible alarm.

## DYNAMIC COOLING / SILENT Mode

The appliance has two different running modes. In Silent mode, once the required temperature is reached, the appliance will run without the fan. In Dynamic Cooling mode the fan cycles on and off to circulate the air even after the required temperature is reached. This ensures consistent humidity and temperature distribution in the wine cooler, creating perfect conditions for long-term storage.

Using the dynamic mode increases the level of noise in operation.

## Door Lock

If the unit is provided with a lock system, the keys are located inside the plastic bag that contains the *User Manual*. Insert the key into the lock and turn it counterclockwise to unlock the door. To lock the door, do the reverse operation, making sure the metal pin is engaged completely. Remove the key and put it in a secure place for safekeeping.

## Glass Shelves

(Only for Models ASDG1521 / ASDG2411.)

Any of the shelves can be removed to store larger items.

When removing the shelf, make sure to have the door all the way open and remove all items first. Hold the front of the shelf, and then gently lift it up and slide out.

In order to replace the shelf, hold the shelf at an angle so the front is higher than the back, and then insert the top hook into the top shelf notch. Then, lower the shelf and insert the bottom shelf hook into the bottom shelf notch.

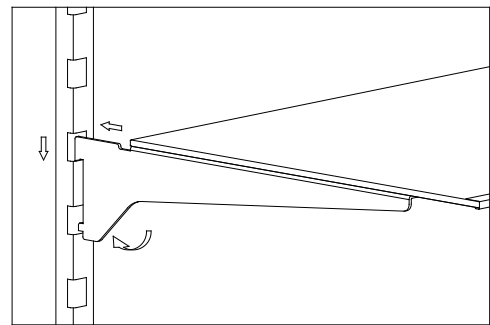

**CAUTION:** When removing or replacing the shelf, use caution not to scratch the sides of the unit.

## Glass Shelves

(Only for Model AL57GPNR.)

To prevent damaging the door gasket, make sure to have the door all the way open when pulling the shelves out of the rail compartment.

Any of the shelves can be removed to store larger items. When removing the shelf from the rail compartment, make sure to remove all items first. Then move the shelf to the position where the notch of the shelf is exactly under the plastic post and lift the shelf. In order to replace the shelf, repeat the steps described above in reverse.

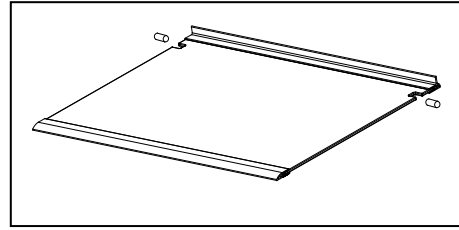

**CAUTION:** When removing or replacing the shelf, use caution not to scratch the sides of the unit.

## Rail Shelves

(Only for Models ASDW1522 / ASDW2412.)

To prevent damaging the door gasket, make sure to have the door all the way open when pulling the shelves out of the rail compartment.

- Any of the shelves can be removed to store larger items.
- When removing the shelf from the rail compartment, make sure to remove all items first. Press the right slide release lever down and at the same time lift the corresponding left slide lever up and pull the shelf out until it is free of tracks and the cabinet.
- To remove the tracks, lift the front of the track straight up and then pull the rear of the track straight outward to release the track hooks from the wall slots. In order to replace the tracks, repeat this procedure in reverse.
- In order to replace the shelf, align the left and right slide channels with the tracks in the cabinet. Ensuring an even track engagement on both sides, gently push the shelf into the cabinet until the tabs lock into place.

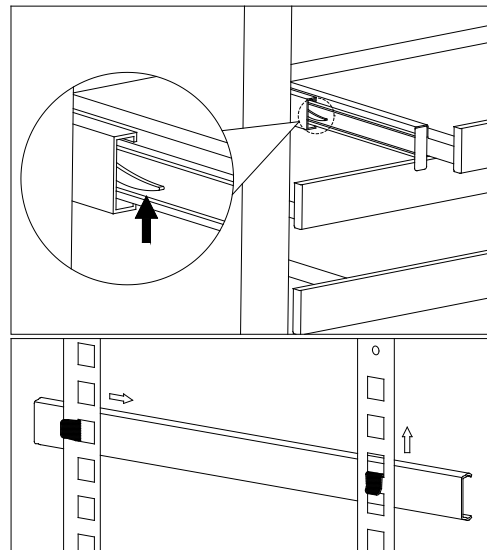

**NOTE:** Make sure the tabs on the full extension shelf guides are fully engaged before loading any bottles. Pull the shelf out all the way to the STOP position and push back in several times to make sure the locking tabs are properly engaged.

**CAUTION:** When removing or replacing the shelf, use caution not to scratch the sides of the unit.

## Defrosting

- The unit defrosts automatically in normal operating conditions.
- The evaporator behind the rear wall of the unit defrosts automatically. The condensate collects in the drainage channel behind the rear wall of the unit and flows through the drainage hole into the drip tray near the compressor where it evaporates.
- However, frost may accumulate on the evaporator if the unit is repeatedly opened in a high heat or high-humidity environment. If this frost pattern does not clear within 24 hours, your unit will require manual defrosting.

## **Storage**

Bottles can differ in size. Accordingly, the actual number of bottles you can store may vary.

The approximate maximum bottle capacity can be achieved when storing traditional 750 ml Bordeaux bottles in bulk storage.

You may load your wine bottles in single rows or by stacking while taking note of the following: if you do not have enough bottles to fill your wine cellar, it is better to distribute the load throughout the wine cellar so as to avoid “all on top” or “all below” type loads.

- Keep small gaps between the walls and the bottles to allow air to circulate. As in an underground cellar, air circulation is important to prevent mold and for a more homogeneous temperature within the cellar.
- To facilitate air circulation, do not overload your wine cellar.
- Avoid obstructing the internal fans (located inside on the rear panel of the wine cellar).
- To prevent bottles from falling, do not try to slide the shelves outward beyond the fixed position.
- Do not pull out more than one loaded shelf at a time as this may cause the wine cellar to tilt forward if not properly installed.

# CARE AND MAINTENANCE

## Cleaning your Appliance

*CAUTION: Failure to unplug the appliance during cleaning could result in electrical shock or other personal injury.*

- Turn off the power, unplug the appliance, and remove all items, including shelves.
- Wash the inside surfaces with a solution of warm water and baking soda (about 2 tablespoons of baking soda to a quart of water).
- Wash the shelves with a mild detergent solution.
- Wring excess water out of the sponge or cloth when cleaning the area where the controls are located, or any electrical parts.
- Wash the outside cabinet with warm water and mild liquid detergent. Rinse well and wipe dry with a clean, soft cloth.
- Do not use steel wool or a steel brush on the stainless steel.

## Power Failure

Most power failures are corrected within a few hours and should not affect the temperature of your appliance if you minimize the number of times the door is opened. If the power is going to be off for a longer period of time, you need to take the proper steps to protect the contents.

## Vacations

- **Short vacations:** Leave the appliance operating during vacations of less than three weeks.
- **Long vacations:** If the appliance will not be used for several months, remove all items and turn off the appliance. Clean and dry the interior thoroughly. To prevent odor and mold growth, leave the door open slightly, blocking it open if necessary.

## Moving your Appliance

1. Remove all items.
2. Securely tape down all loose items (shelves) inside your appliance.
3. Turn the adjustable legs up to the base to avoid damage.
4. Tape the door shut.
5. Be sure the appliance stays secure in an upright position during transportation. Also, protect the outside of the appliance with a blanket or similar item.

## Energy-Saving Tips

- The appliance should be located in the coolest area of the room, away from heat-producing appliances and out of direct sunlight.
- Ensure that the unit is adequately ventilated. Never cover air vents.
- Do not keep the door open any longer than necessary.

# TROUBLESHOOTING

You can solve many common problems easily, saving you the cost of a possible service call. Try the suggestions below to see if you can solve the problem before calling the servicer.

<b>PROBLEM</b>	<b>POSSIBLE CAUSE</b>	<b>REMEDY</b>
<i>The appliance does not operate.</i>	<i>The appliance is not connected to a power supply. The appliance is turned off. A tripped circuit breaker or a blown fuse.</i>	<i>Connect the appliance.  Switch on the appliance. Switch on the circuit breaker or replace fuse.</i>
<i>The appliance is not cold enough.</i>	<i>The temperature is not set correctly. The ambient temperature could require a lower set temperature setting. The door was opened too often.  The door was not closed completely. The door is not hermetically sealed.  The condenser is dirty.  The ventilation opening is blocked or too dusty.</i>	<i>Check the set temperature. Set a lower temperature.  Do not open the door more often than necessary. Close the door properly. Check the door seal and clean or replace it. Clean the condenser when necessary.  Clear the obstructions and clean off the dust.</i>
<i>The appliance turns itself on and off frequently.</i>	<i>The room temperature is higher than average. A large number of items have been added to the unit.  The door is opened too often.  The door is not closed completely. The door gasket does not seal properly.</i>	<i>Put the appliance in a cooler place.  Leave the appliance to work for a while until the set temperature has been reached. Do not open the door more often than necessary. Close the door properly. Check the door seal and clean or replace it.</i>
<i>The light does not work.</i>	<i>The appliance is not connected to a power supply. The tripped circuit breaker or a blown fuse. The light was switched off on the control panel.</i>	<i>Connect the appliance.  Switch on the circuit breaker or replace fuse. Switch on the light.</i>
<i>Vibrations</i>	<i>The appliance is not properly leveled.</i>	<i>Level the appliance with adjustable feet.</i>
<i>The appliance seems to make too much noise.</i>	<i>A rattling noise may come from the flow of the refrigerant, which is normal. As each cycle ends, you may hear gurgling sounds caused by the flow of refrigerant in your appliance. If temperature fluctuations occur, the contraction and expansion of the inner walls may cause popping and crackling noises.</i>	
	<i>The appliance is not properly leveled.</i>	<i>Level the appliance with adjustable feet.</i>
<i>The door will not close properly.</i>	<i>The appliance is not properly leveled.  The door was reversed and not properly re-installed. The gasket is dirty. The shelves are out of position.</i>	<i>Level the appliance with adjustable feet. Check the door hinge and reassemble it correctly. Clean the door gasket. Check the shelves and refit correctly.</i>
<i>Display "E0", "E1", "E2", "E3", "E4",</i>	<i>"E0" indicates a communication error for 3- zone models. "E1" or "E2" indicates that the air</i>	<i>Call for service.</i>

<p>"E5", "E6" or "E7".</p>	<p><i>temperature sensor has failed.</i>  <i>"E3" or "E4" indicates that the defrost sensor in the evaporator has failed.</i>  <i>"E5" indicates a defrost heater failure.</i>  <i>"E6" indicates a solenoid valve failure.</i>  <i>"E7" indicates a door switch failure.</i></p>	
<p><i>The alarm sounds and the temperature display flashes.</i></p>	<p><i>Has the appliance door been open for longer than 60 seconds? If not, then the temperature has risen higher or fallen lower than the set temperature. This could be due to:</i>  <i>The appliance door has been opened too often.</i>  <i>The ventilation opening is covered or too dusty.</i>  <i>A lengthy interruption to the power supply.</i>  <i>A large number of items have been added to the unit.</i></p>	<p><i>If yes, close the door.</i></p> <p><i>Do not open the door more often than necessary.</i>  <i>Clear the obstructions and clean off the dust.</i>  <i>Let the appliance work for a while until the set temperature has been reached.</i></p>
<p><i>The icon "--" is lit up and flashing in the temperature display.</i></p>	<p><i>The display temperature is out of range.</i></p>	<p><i>Only temperatures within the range 0~99°F/-9~37°C can be displayed. If the temperature is not within this range, the icon "--" will be displayed instead. This is normal.</i></p>

If you have checked the table above and find that you still need help with your appliance, call our Customer Service facility at **800-932-4267** between 9:00 AM and 5:00 PM ET or visit <https://www.summitappliance.com/support>. We will do our best to answer your questions.

**CALIFORNIA CARB/SNAP DISCLOSURE**

**This product uses eco-friendly hydrocarbon refrigerant and fully complies with California CARB regulations.**

However, we are required by California Law to provide the following disclosure statement in every product sold in California.

*"This equipment is prohibited from use in California with any refrigerants on the 'List of Prohibited Substances' for that specific end-use, in accordance with California Code of Regulations, title 17, section 95374. This disclosure statement has been reviewed and approved by Felix Storch, Inc. and Felix Storch, Inc. attests, under penalty of perjury, that these statements are true and accurate."*

This product does **not** use any refrigerants on the 'List of Prohibited Substances'"

# NOTES

# LIMITED WARRANTY

## ONE-YEAR LIMITED WARRANTY

Within the 48 contiguous United States, for one year from the date of purchase, when this appliance is operated and maintained according to instructions attached to or furnished with the product, warrantor will pay for factory-specified parts and repair labor to correct defects in materials or workmanship. Service must be provided by a designated service company. Outside the 48 states, all parts are warranted for one year from manufacturing defects. Plastic parts, shelves and cabinets are warranted to be manufactured to commercially acceptable standards, and are not covered from damage during handling or breakage.

## 5-YEAR COMPRESSOR WARRANTY

1. The compressor is covered for 5 years.
2. Replacement does not include labor.

### *ITEMS WARRANTOR WILL NOT PAY FOR:*

1. Service calls to correct the installation of your appliance, to instruct you how to use your appliance, to replace or repair fuses or to correct wiring or plumbing.
2. Service calls to repair or replace appliance light bulbs or broken shelves. Consumable parts (such as filters) are excluded from warranty coverage.
3. Damage resulting from accident, alteration, misuse, abuse, fire, flood, acts of God, improper installation, installation not in accordance with electrical or plumbing codes, or use of products not approved by warrantor.
4. Replacement parts or repair labor costs for units operated outside the United States.
5. Repairs to parts or systems resulting from unauthorized modifications made to the appliance.
6. The removal and reinstallation of your appliance if it is installed in an inaccessible location or is not installed in accordance with published installation instructions.

## DISCLAIMER OF IMPLIED WARRANTIES; LIMITATION OF REMEDIES

CUSTOMER'S SOLE AND EXCLUSIVE REMEDY UNDER THIS LIMITED WARRANTY SHALL BE PRODUCT REPAIR AS PROVIDED HEREIN. IMPLIED WARRANTIES, INCLUDING WARRANTIES OF MERCHANTABILITY OR FITNESS FOR A PARTICULAR PURPOSE, ARE LIMITED TO ONE YEAR. WARRANTOR SHALL NOT BE LIABLE FOR INCIDENTAL OR CONSEQUENTIAL DAMAGES. SOME STATES DO NOT ALLOW THE EXCLUSION OR LIMITATION OF INCIDENTAL OR CONSEQUENTIAL DAMAGES, OR LIMITATIONS ON THE DURATION OF IMPLIED WARRANTIES OF MERCHANTABILITY OR FITNESS, SO THESE EXCLUSIONS OR LIMITATIONS MAY NOT APPLY TO YOU. THIS WARRANTY GIVES YOU SPECIFIC LEGAL RIGHTS AND YOU MAY ALSO HAVE OTHER RIGHTS, WHICH VARY FROM STATE TO STATE.



**WARNING:** This product can expose you to chemicals including Nickel (Metallic) which is known to the State of California to cause cancer.

For more information go to [www.P65Warnings.ca.gov](http://www.P65Warnings.ca.gov)

Note: Nickel is a component in all stainless steel and some other metal components.

**Felix Storch, Inc.**  
An ISO 9001:2015 registered company  
770 Garrison Ave  
Bronx, New York 10474  
[www.summitappliance.com](http://www.summitappliance.com)

**SUMMIT**  
P R O F E S S I O N A L

For parts and accessory ordering,  
troubleshooting and helpful hints, visit:  
[www.summitappliance.com/support](http://www.summitappliance.com/support)