

LIEBHERR

Installation Instructions

For Fully Integrated NoFrost
Combined Refrigerator-Freezers

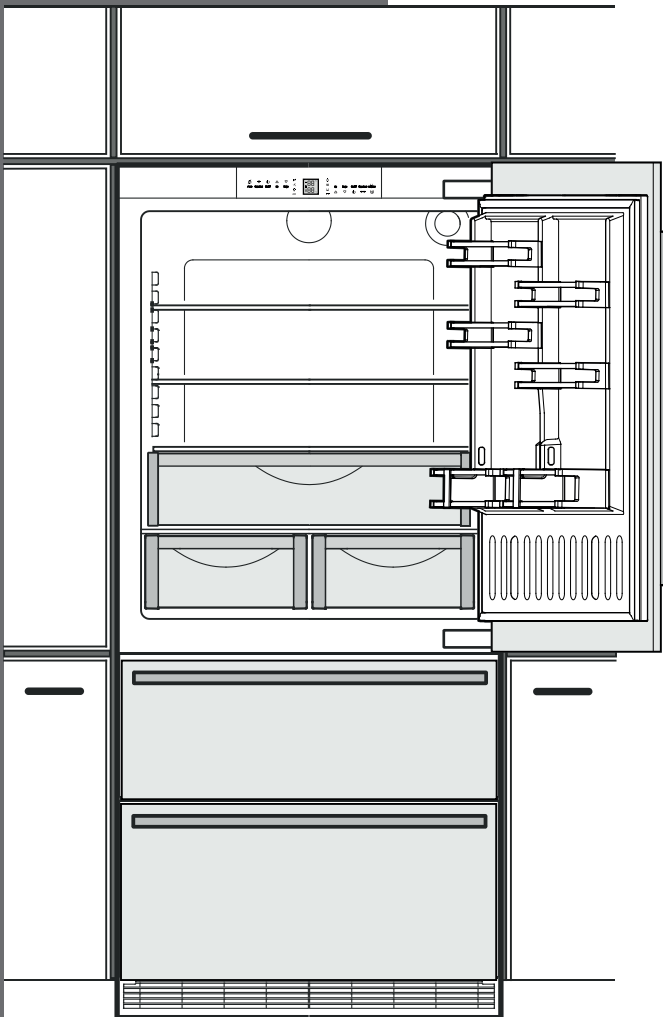

HC 2080/2081
HCB 2080/2081
7084 851-00

IMPORTANT

Please Read and Follow these Instructions

These instructions contain Danger, Warning and Caution notes.

This information is important for safe and efficient installation and operation.

Always read and comply with all Danger, Warning and Caution notes!



DANGER!

Danger indicates a hazard which will cause serious injury or death if precautions are not followed.



WARNING!

Warning indicates a potentially hazardous situation which, if not avoided, could result in death or serious injury.



CAUTION!

Caution indicates a potentially hazardous situation which, if not avoided, may result in minor or moderate injury.

IMPORTANT

This indicates information that is especially relevant to a problem-free installation and operation.

Note to the Installer

It is very important to follow the instructions in the manual to ensure proper installation and operation of the unit.

Before installing the unit, be sure to thoroughly read and understand all of the information in this manual.



WARNING!

Electrocution hazard.

Do not connect to the electrical outlet before the installation is completed.

Contents

Page

Unit dimensions	4
Door swing clearance	4
Unit venting	4
Cabinet opening dimensions	5
Panel dimensions - framed cabinet design	6
Panel dimensions - frameless cabinet design.....	7
Mounting the anti tipping device on concrete floors.....	8
Mounting the anti tipping device on wooden floors.....	8
Mounting the anti tipping device in cabinets deeper than 24"	9
Cover strips	9
IceMaker	
Safety instructions and warnings.....	10
Water connection Requirements	10
Water connection Adapter	10
Connection to the water supply	11
Leveling the appliance	12
Fastening the appliance in the recess.....	12
Adjusting the refrigerator door.....	12
Adjusting the front of the drawer	13
Before mounting the door panels	13
Mounting the attachment brackets onto the door panels	14
Mounting the refrigerator door panels.....	15-16
Mounting the freezer drawer panels	17
Mounting the ventilation grille	17

R600a Refrigerant



WARNING!

The refrigerant contained within the appliance R600a is environmentally friendly, but flammable. Leaking refrigerant can ignite.

To prevent possible ignition follow the warnings below:

- **Keep ventilation openings, in the appliance enclosure or in the built-in structure, clear of obstruction.** →
- **Do not damage the refrigerant circuit.**
- **Any repairs and work on the appliance should only be performed by the customer service department.**

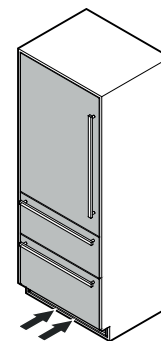

Disposal of Old Appliance



DANGER!

Risk of child entrapment.

Child entrapment and suffocation are not problems of the past.

Junked or abandoned refrigerators are still dangerous – even if they will sit for “just a few days.”

If you are getting rid of your old refrigerator, please follow these instructions to help prevent accidents.

Before you discard old appliances:

- **Take off the doors.**
- **Leave the shelves in place so that children may not easily climb inside.**
- **Cut off the power cable from the discarded appliance. Discard separately from the appliance.**
- **Be sure to follow your local requirements for disposal of appliances.**

Contact the trash collection agency in your area for additional information.

Disposal of Carton

The packaging is designed to protect the appliance and individual components during moving and is made of recyclable materials.



WARNING!

Keep packaging materials away from children. Polythene sheets and bags can cause suffocation!

Please recycle packaging material where facilities are available.

Electrical Safety

Connect this appliance to a 15 amp or 20 amp, 110-120 VAC, circuit which is grounded and protected by a circuit breaker or fuse.

We recommend using a dedicated circuit for this appliance to prevent circuit overload and the chance of interruption to the appliance.

This appliance is equipped with a three-prong (grounding) polarized plug for your protection against possible shock hazards.

Where a two-prong wall receptacle is encountered, contact a qualified electrician and have it replaced with a properly grounded three-prong receptacle in accordance with all local codes and ordinances.

Disconnect power before installing optional Side By Side Kit. Side by Side Kit is only to be installed on models HC 2061 and HCB 2061.



WARNING!

Electrocution hazard.

Electrical grounding required.

- **Do not remove the round grounding prong from the plug.** →

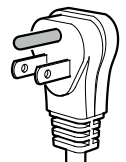

- **Do not use extension cords or ungrounded (two prong) adapters.**

- **Do not use a power cord that is frayed or damaged.**

- **Do not use a power strip.** →

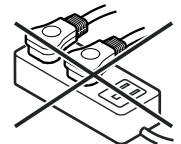

Failure to follow these instructions may result in fire, electrical shock or death.

Blocking for Safety



WARNING!

To avoid a hazard due to instability of the appliance, it must be fixed in accordance with the instructions.

PLANNING INFORMATION

Unit Dimensions - Figure 1

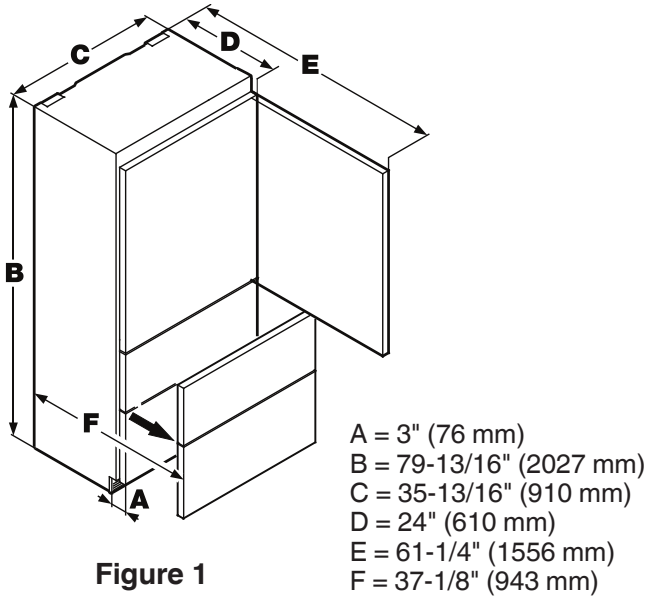

Figure 1

Door Swing Clearance - Figure 2

Please allow for door swing clearance at locations next to a wall.

The illustrated measurement is without mounted front panels. Be sure to add your panel thickness and handle depth to this measurement in order to avoid interferences.

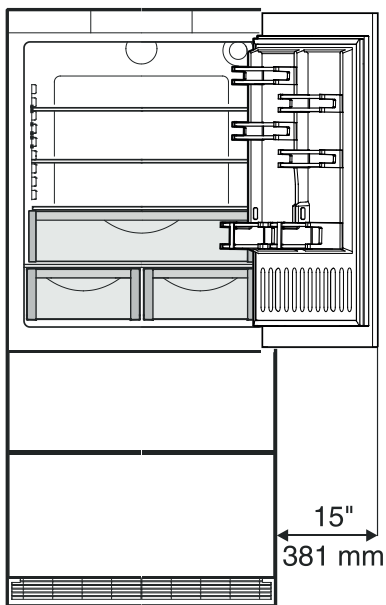

Figure 2

Unit Venting - Figure 3

HC 2080/2081 appliances do not require any ventilation openings in the cabinet. The required airflow is directed through the toe kick area.

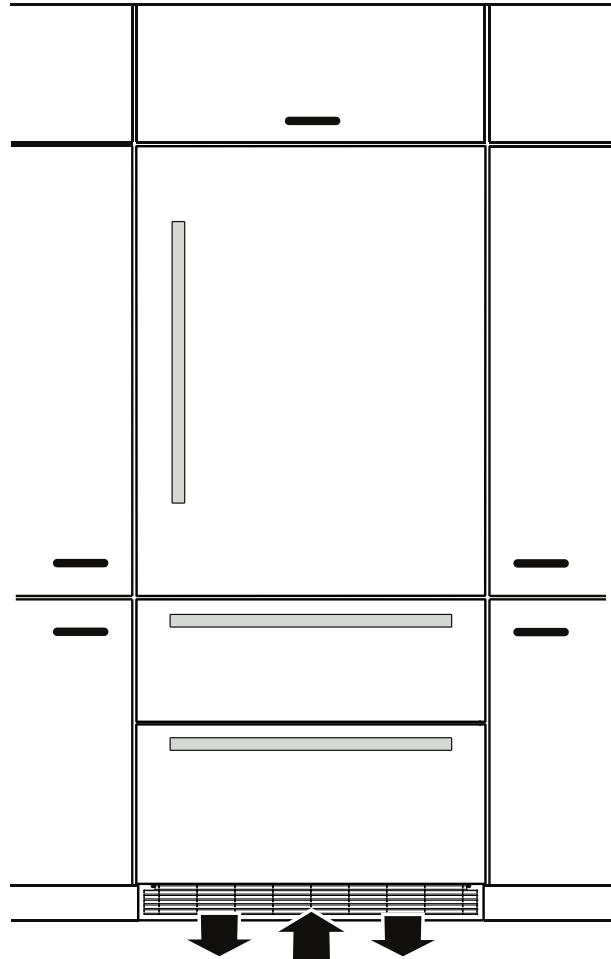

Figure 3

It is important to use the provided cover grille for the ventilation opening. This opening must not be covered with a cabinet base.

PLANNING INFORMATION

Cabinet Opening Dimensions - Figure 4

Inset cabinet Depth D	Frameless/faceframe cabinet Depth D
24" + panel thickness	24"

For appliance with panel to be flush, adjacent cabinetry depth must equal appliance depth (24") plus panel thickness (5/8" - 3/4").

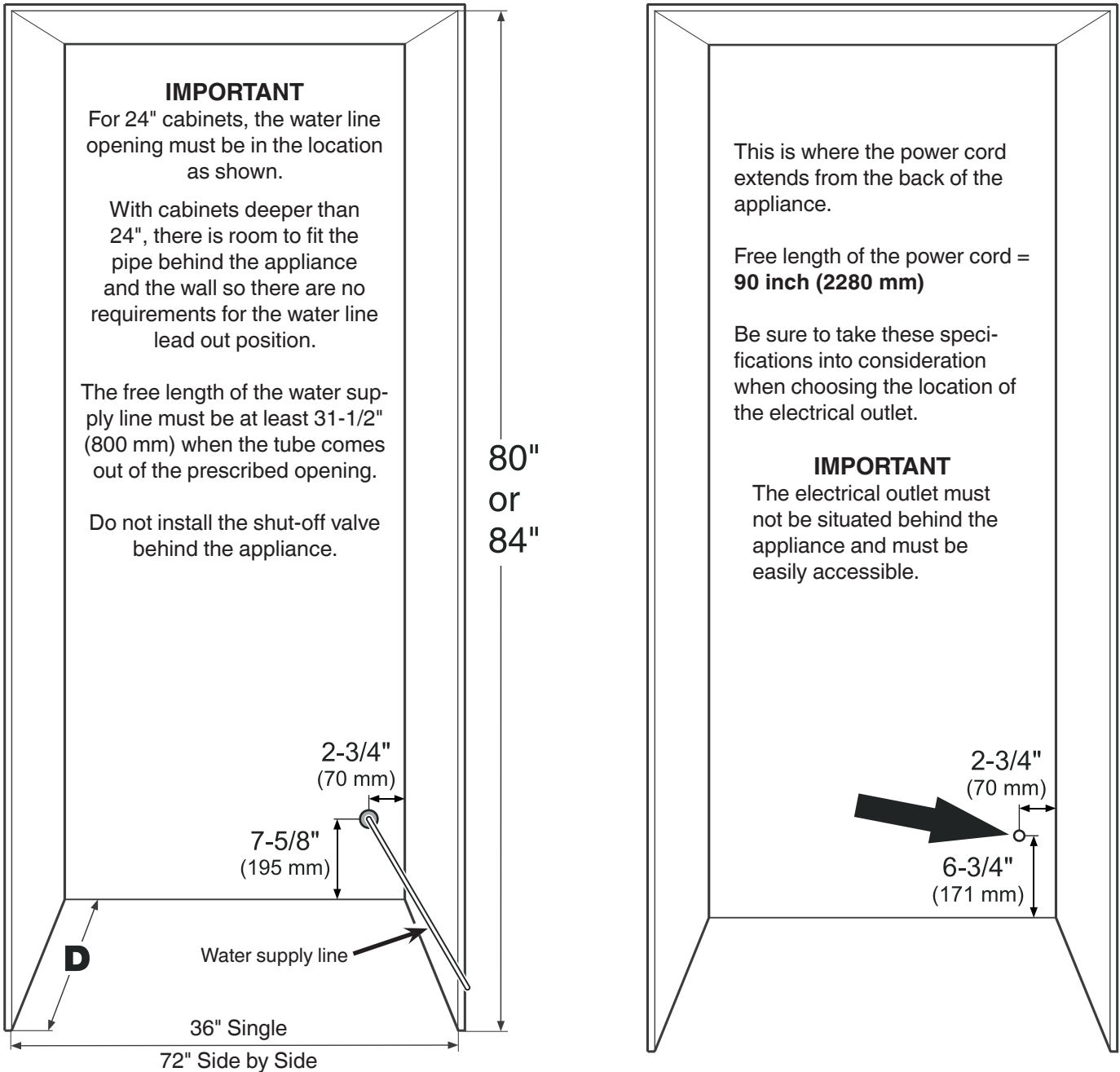

Figure 4

PLANNING INFORMATION

Panel Dimensions - Inset Installation Style - Figure 5

Appliance and panels sit fully within the opening and are flush with what could be its own box, between two pantry cabinets or decorative columns, etc. This is the most common installation scenario.

The panels should be at least 5/8 inch (16 mm) thick to allow the connecting rails to be fastened to them.

IMPORTANT

The maximum panel thickness is 3/4" (19 mm).
The door panel weight must not exceed 60 lb (27 kg).

You can order stainless steel panels for inset installation style.

Refrigerator door panel 80"- article number 9900 333-00

Refrigerator door panel 84"- article number 9900 331-00

Freezer drawer panels - article number 9900 323-00

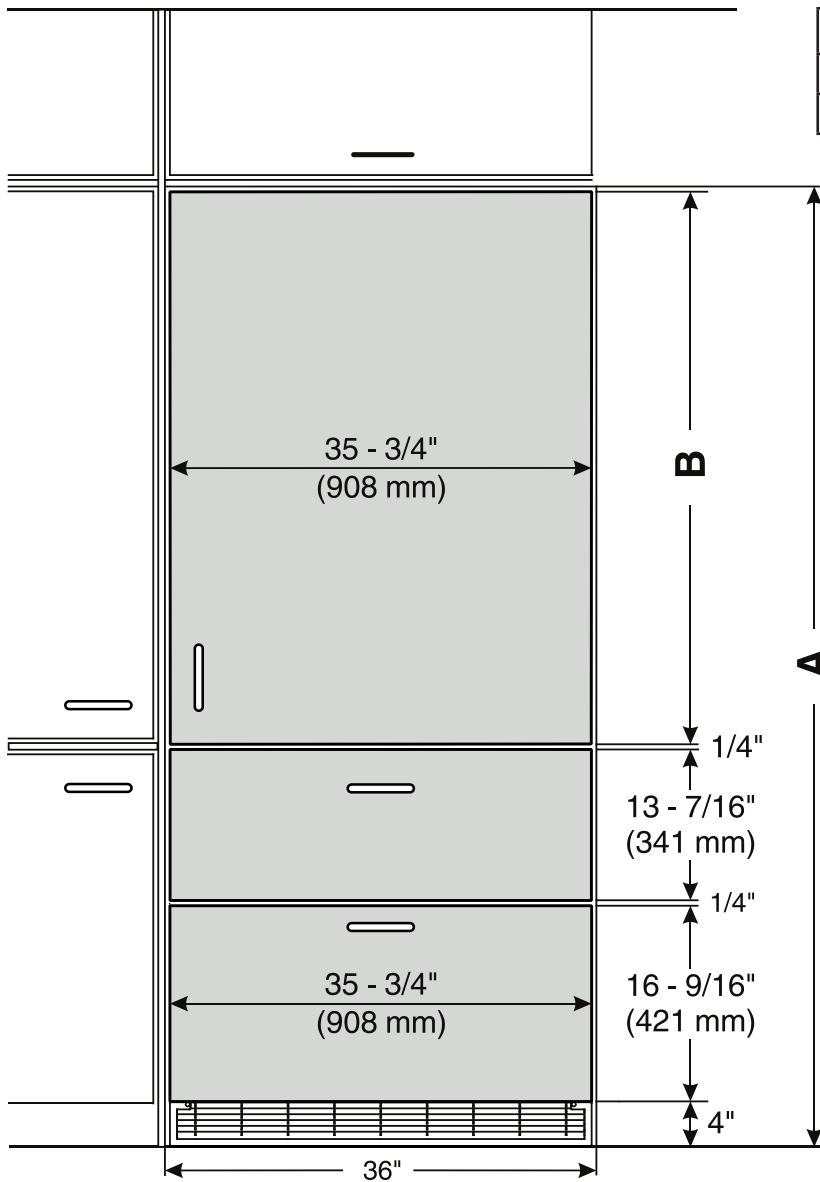

Cabinet opening A	Refrigerator door panel B
80" (2032 mm)	45-1/4" (1150 mm)
84" (2134 mm)	49-1/4" (1251 mm)

Figure 5

PLANNING INFORMATION

Panel Dimensions - Frameless Installation Style - Figure 6

With this installation style, these wider appliance panels partially overlay the shared side gables of adjacent cabinetry so as to mimic the look of a frameless style cabinet.

The gap between panels with frameless installation style is 1/4" (6 mm). The panels should be at least 5/8 inch (16 mm) thick to allow the connecting rails to be fastened to them.

IMPORTANT

The maximum panel thickness is 3/4" (19 mm).
The door panel weight must not exceed 60 lb (27 kg).

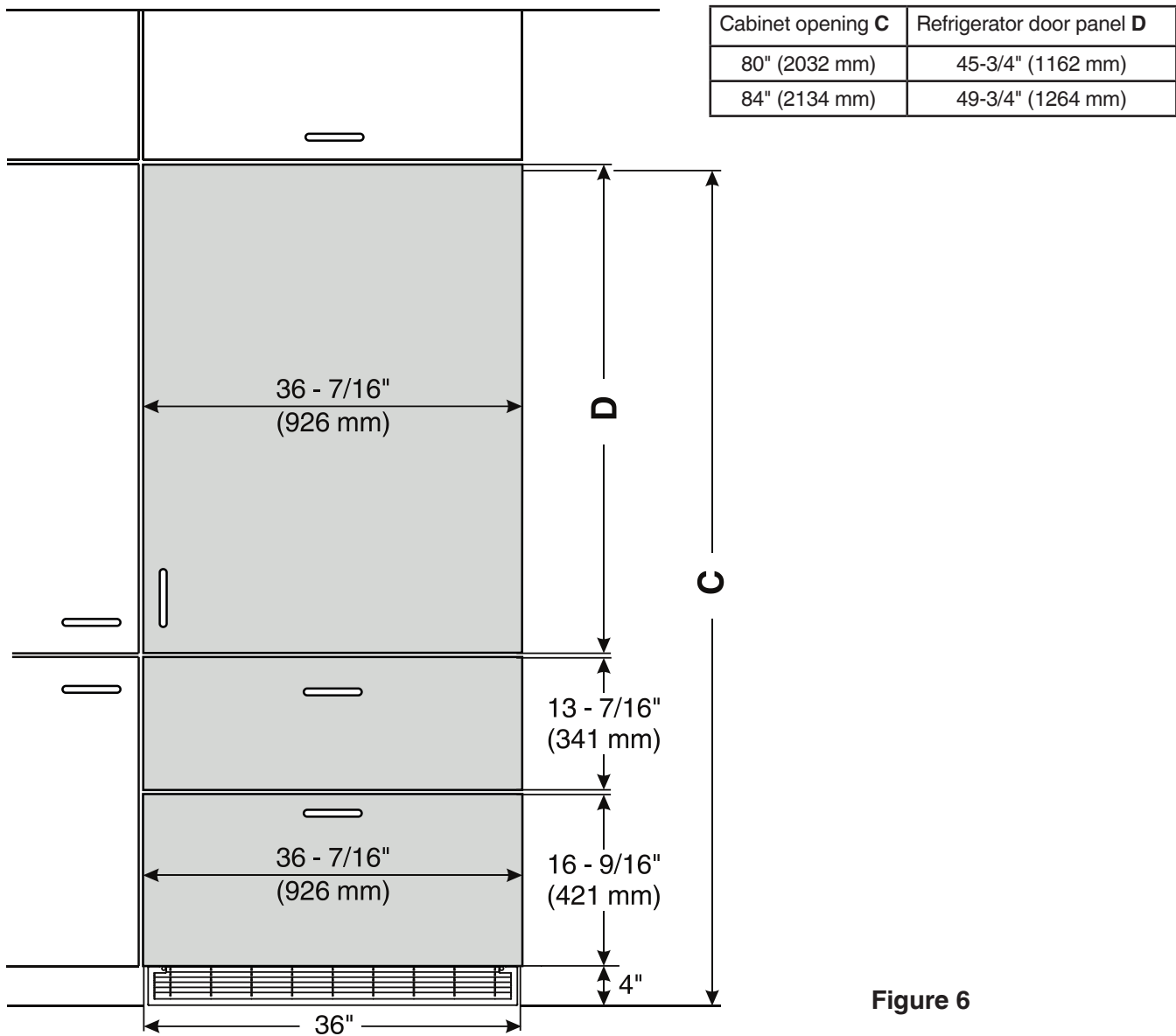

Figure 6

BLOCKING FOR SAFETY

Mounting the Anti Tipping Device on Concrete Floors - Figure 7 - 8

Secure the appliance in place so it does not tip forward when the fully stocked door is opened. The anti tipping bracket is provided with the appliance.

1. Mark the center line of the appliance on the back wall. Align the anti tipping bracket center to this line.

WARNING

Be sure that there is no plumbing or electrical wiring located in this area which screws or drills could damage.

2. Drill a 3/8" diameter hole in any position as shown in **Figure 5** using a carbide drill bit.
The depth of the holes must exceed the overall length of the anchors provided.
Clean the holes after drilling.
3. Attach washer and screw on hex nut to the end of each anchor.
Drive in all 3 anchors.
Align the bracket center to the center line on the back wall again.
Fasten the anchors by turning the hex nut.
4. Fasten bracket with 3 screws (1/4" x 2-1/8") into the wall plate (**Figure 8**).

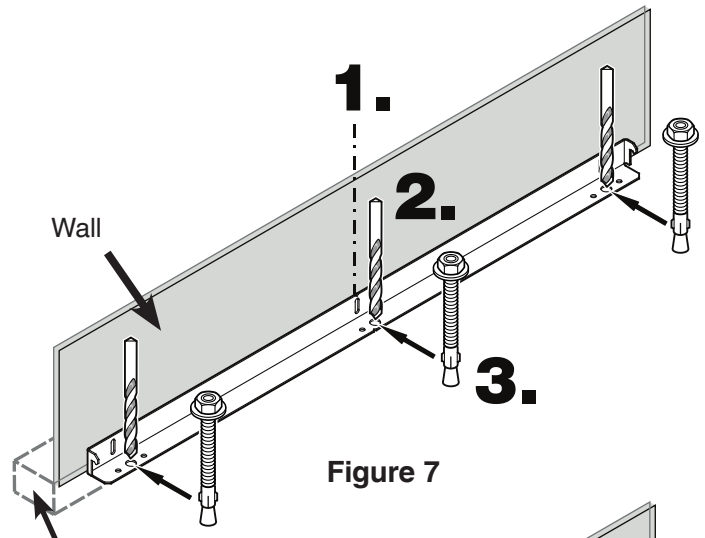

Figure 7

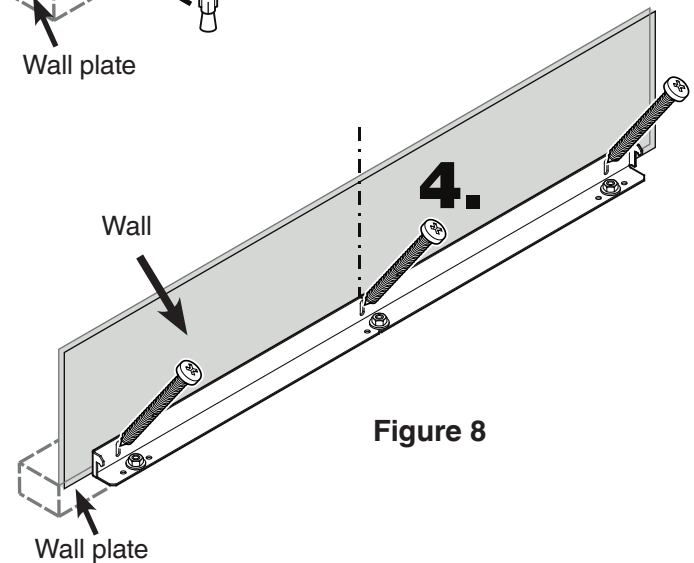

Figure 8

Mounting the Anti Tipping Device on Wooden Floors - Figure 9

1. Mark the center line of the appliance on the back wall. Align the anti tipping bracket center to this line.

WARNING

Be sure that there is no plumbing or electrical wiring located in this area which screws or drills could damage.

2. Fasten bracket to the wooden floor using 5 screws (1/4" x 2-1/8"). Drill pilot holes if necessary.
3. Fasten bracket with 3 screws (1/4" x 2-1/8") into the wall plate.

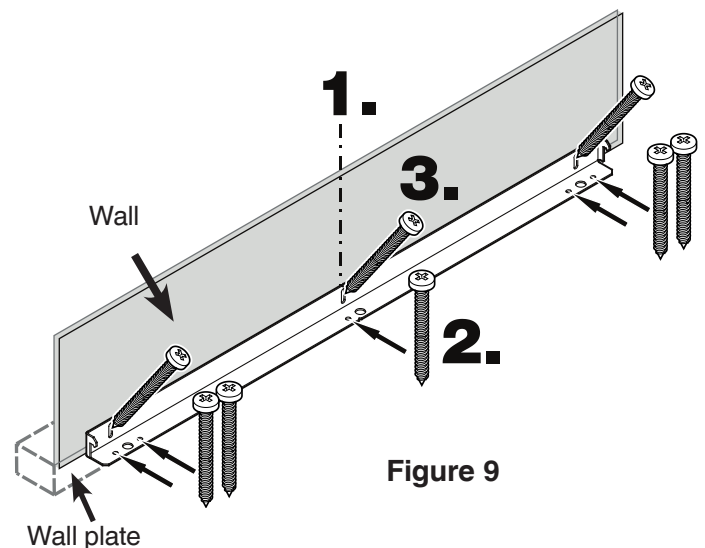

Figure 9

BLOCKING FOR SAFETY

Mounting the Anti Tipping Device in Cabinets deeper than 24" - Figure 10 - 11

To ensure the compressor mounting plate reaches the anti tipping bracket in cabinets deeper than 24", a wooden spacer must be mounted between the appliance back and the wall. The anti tipping bracket will be fastened to the floor downwards and to the spacer backwards.



WARNING

Be sure the wooden spacer is fastened securely to the floor.

Measuring for mounting the wooden spacer on inset kitchen cabinets - Figure 10

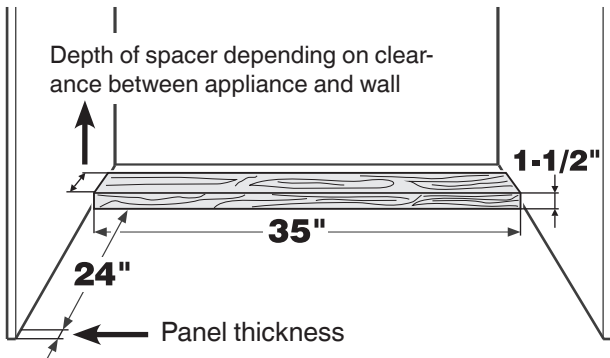

Figure 10

Measuring for mounting the wooden spacer on frameless kitchen cabinets - Figure 11

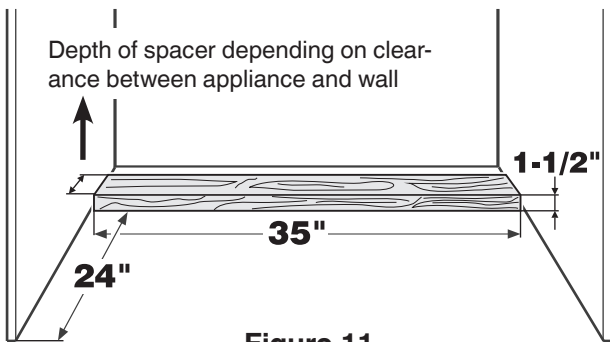

Figure 11

IMPORTANT

If the floor slopes down sideways, the anti-tipping bracket must be fitted horizontally. Lay down spacers in the appropriate positions.

Cover Strips - Figure 12

Apply cover strips above, between and below the securing plates on the side walls of the appliance.

Cut the cover strips to the length shown in **Figure 12**.

Fit the adhesive cover strips leaving a gap of 1/4" to each securing plate. This ensures problem-free fitting of the covers.

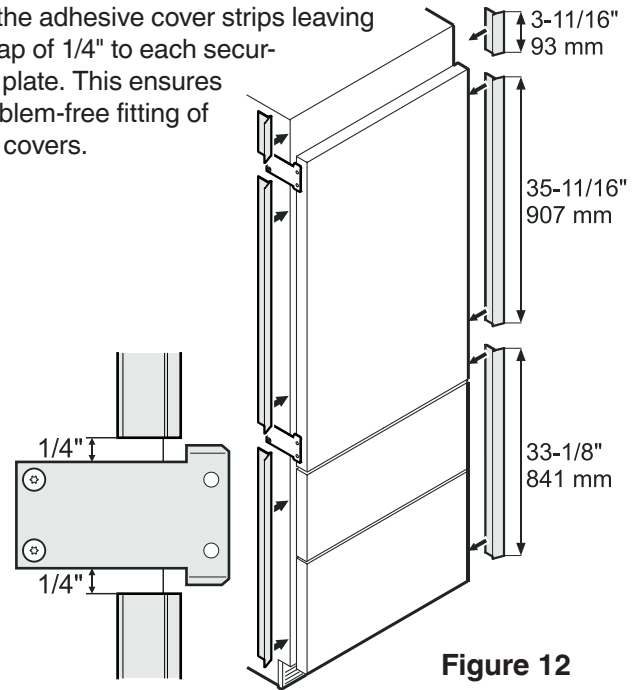

Figure 12

ICEMAKER

Safety Instructions and Warnings

- Do not install the water connection while the combined refrigerator-freezer is connected to an electrical outlet.
- The connection to the water supply may only be made by a trained and licensed plumber.
- All equipment and devices used to supply the water to the appliance must comply with the current regulations for your geographical area.



WARNING!

Connect to potable water supply only.

Water Connection Requirements

- The water supply pressure requirements are different based on whether or not the supplied Liebherr water filter is installed.

With the filter installed, the pressure must be in the range of **40-90 psi (2.8-6.2 bar)**.

Without the filter installed, the acceptable pressure range is **22-87 psi (1.5-6 bar)**.

Failure to meet these requirements will likely result in ice maker malfunction and possibly cause a water leakage that can damage flooring and surrounding furniture.

- A shut-off valve, must be installed between the hose line and the main water supply so the water supply can be stopped if necessary.

IMPORTANT

Do not install the shut-off valve behind the appliance.

Water Connection Adapter - Figure 13

IMPORTANT

Only use the supplied adapter for connection to the solenoid valve. The solenoid valve has a metric R3/4 male connector. Any attempt to use other adapters for connection could damage the thread on the solenoid valve.

The supplied adapter enables different connection options for different kinds of water lines. A water line is not supplied with the appliance.

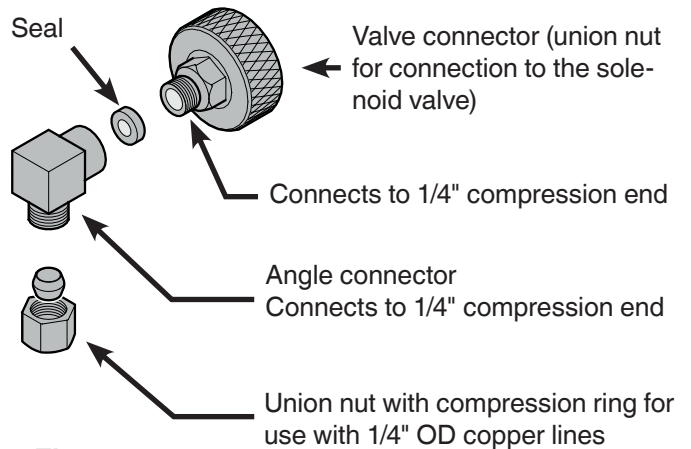

Figure 13

The connection to the valve connector can be done with or without the angle connector, as required.

Braided style ice maker hoses can be connected directly to the threaded ends.

For connection with 1/4" OD copper lines, use the union nut with compression ring.

IMPORTANT

Make sure that the connection is fitted with a seal and is tight.

- Insert the water strainer supplied into the valve connector (**Figure 14**).

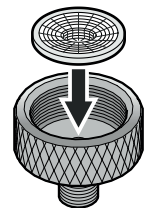

Figure 14

Connection to the Water Supply

1. Move the appliance towards the final position and leave enough space to work behind.
2. Insert the water supply line into its intended opening at the back of the appliance (Figure 15).
3. Move the power supply line to the area of the electrical outlet.

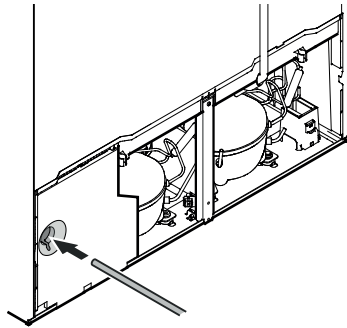

Figure 15

⚠ WARNING!

Do not connect to the electrical outlet before the installation is completed and the water line is connected to the solenoid valve.

4. Push the appliance slowly to the back wall until the compressor mounting plate makes contact with the anti-tipping bracket (Figure 16).

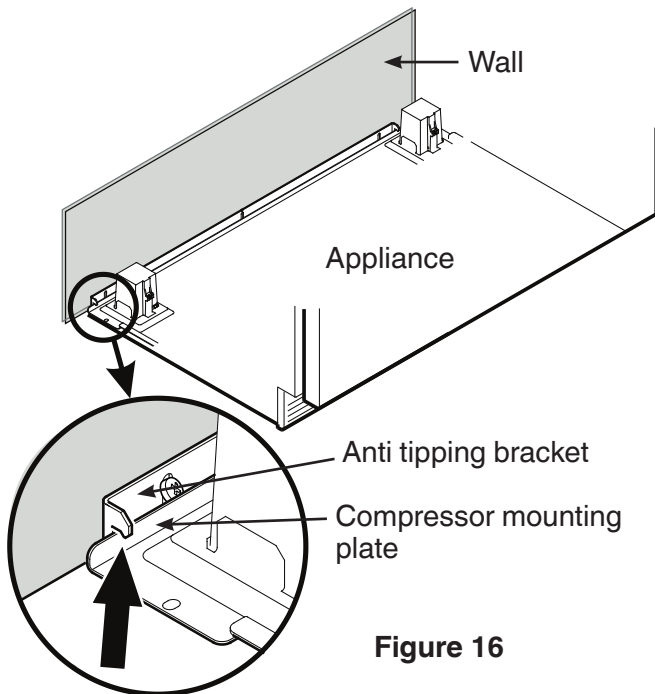

Figure 16

⚠ WARNING!

To prevent the appliance from tipping forward the compressor mounting plate must have contact with the anti tipping bracket (Figure 16).

5. Remove the cover from the solenoid valve (Figure 17).
6. Connect the water line to the adapter in the respective configuration, depending on the type of water line used. Figure 18 shows the configuration with a copper line as an example.
7. Bleed the air from the water line by opening the water supply temporarily.

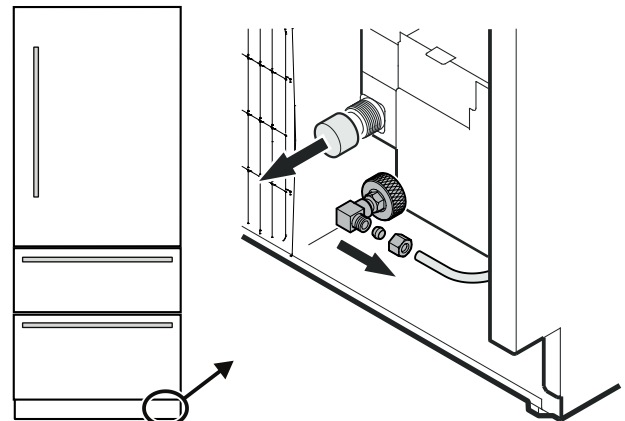

Figure 17

8. Screw the adapter onto the solenoid valve (Figure 18).

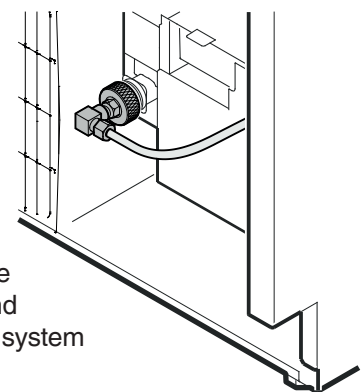

Figure 18

9. Open the shut-off valve for the water supply and check the entire water system for leaks.

INSTALLATION

Leveling the Appliance - Figure 19

1. Adjust the height of the appliance at the front by twisting the leveling feet (1) (A/F 27). Use the open-ended spanner provided.
2. Adjust the height of the appliance at the rear by turning the adjusting bolts (2).
3. Rotate leveling feet (1) until firmly in place against the floor.

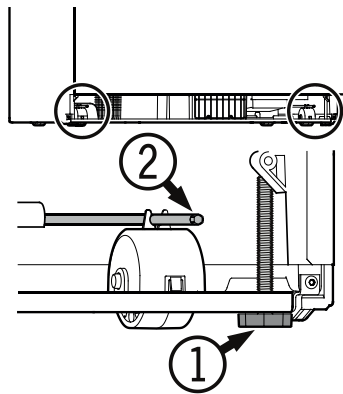

Figure 19

⚠ WARNING

To prevent the appliance from tipping forward the leveling feet (1) (Figure 19) must have contact with the floor.

Fastening the Appliance in the Recess - Figure 20

Fasten the appliance in the recess through the pre-mounted supports at left and right on the appliance housing using screws 4 x 16 mm. Then click the covers supplied into place.

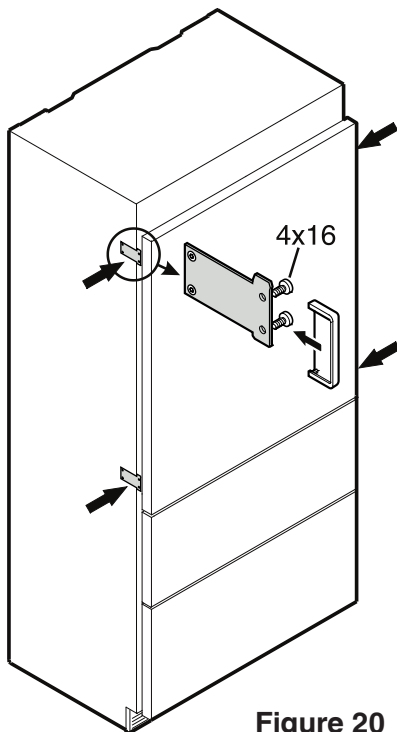

Figure 20

Adjusting the refrigerator door - Figure 21

The lateral tilt of the refrigerator door can be adjusted if required. Undo screws (1). Adjust the lateral tilt using the grub screw (2) (Allen key A/F 2.5).

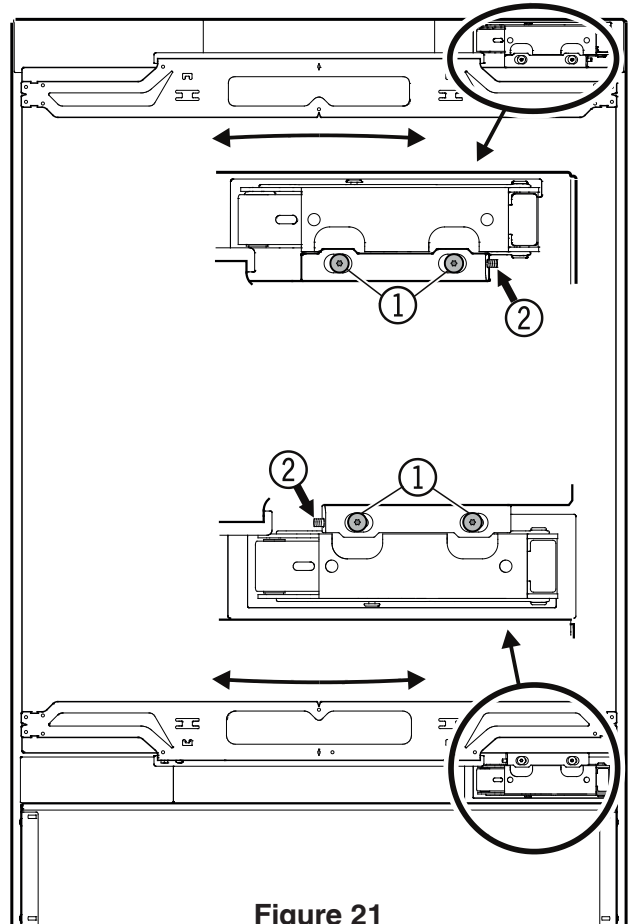

Figure 21

Adjusting the front of the drawer -

Figure 22

If required, the front of the freezer drawers can be adjusted.

Transfer the screws shown in the illustration (on the left and right sides of the freezer drawer) individually to the long slots below.

Tighten the screws in the front of the drawer once it is in the right position.

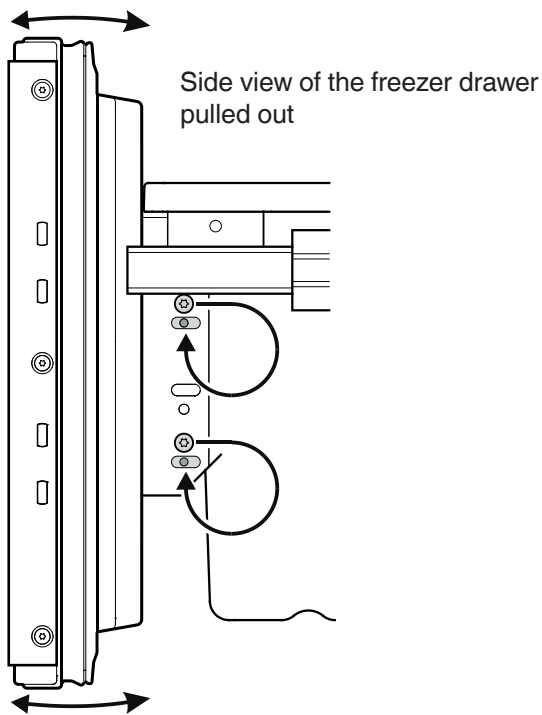

Figure 22

Before Mounting the Door Panels -

Figure 23

Remove cover (1) and unscrew the upper and lower attachment bracket (2) of the refrigerator door. These brackets will be mounted onto the refrigerator door panel.

IMPORTANT

The nuts are needed to fit the premounted panel onto the refrigerator door.

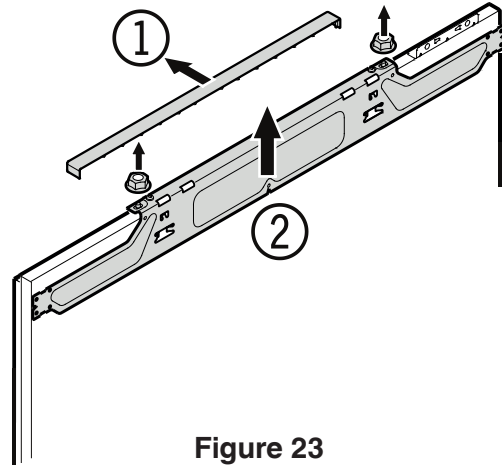

Figure 23

Unscrew the attachment brackets of both freezer drawers. These brackets will be mounted onto the freezer drawer panels (**Figure 24**).

IMPORTANT

The screws are needed to fit the premounted panels onto the freezer drawers.

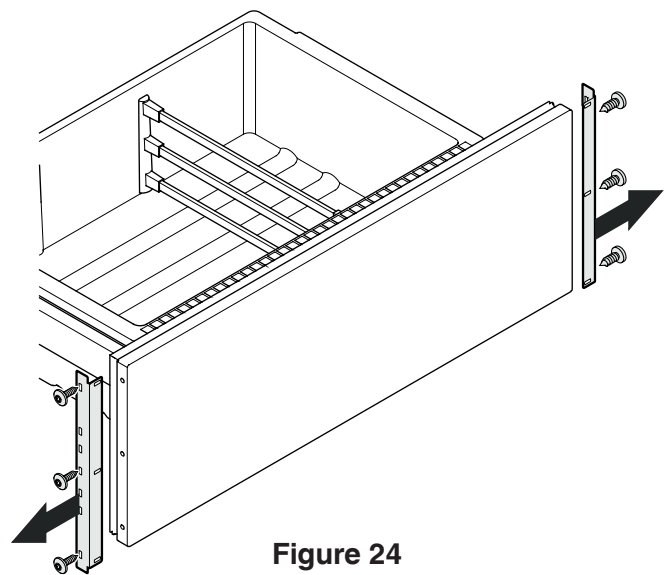

Figure 24

INSTALLATION

Mounting the Attachment Brackets onto the Door Panels - Figure 25

Mark a line with a distance of 41" and 4-1/4" from the bottom of the refrigerator door panel.

Align one of the dismantled brackets of the refrigerator door to the line on the refrigerator door panel as shown in **Figure 25 a**. Fasten the bracket with any hole wherever possible using a minimum of 6 screws 4 x 16 mm.

Align the second bracket of the refrigerator door to the bottom line on the refrigerator door panel as shown in **Figure 25 b**. Fasten the bracket with any hole wherever possible using a minimum of 6 screws 4 x 16 mm.

Fasten the brackets provided onto the freezer drawer panels using three screws (4 x 16 mm) for each bracket considering the measurement in **Figure 25 c**.

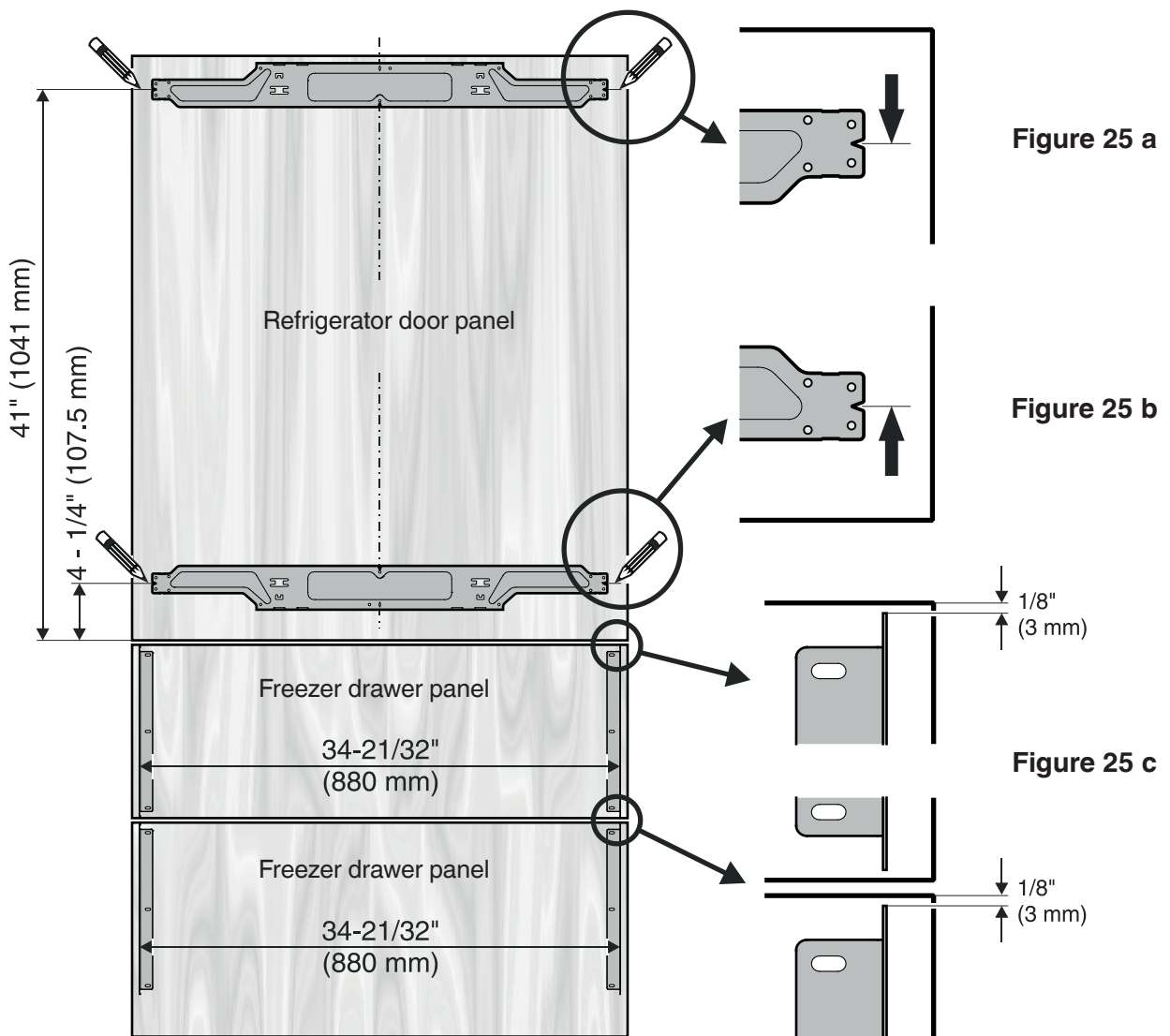
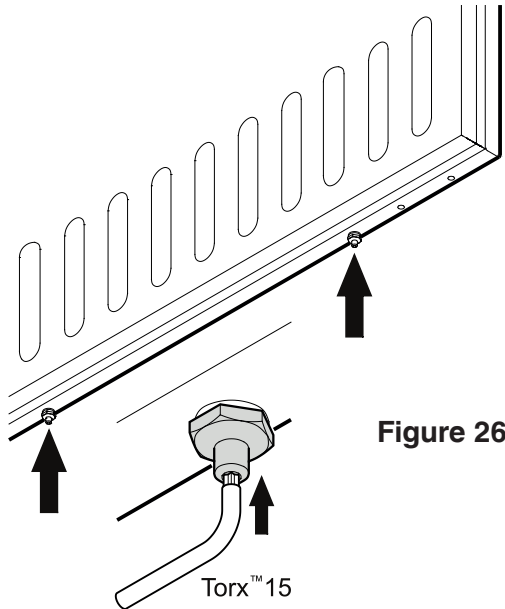

Figure 25

Mounting the Refrigerator Door Panel

1. Turn in the adjusting bolts on the bottom of the refrigerator door as far as possible (**Figure 26**).



4. Close the door and check the height of the panel.
5. Align the panel in its vertical position if necessary. Loosen the hex nuts and turn the adjusting bolts (**Figure 28**).

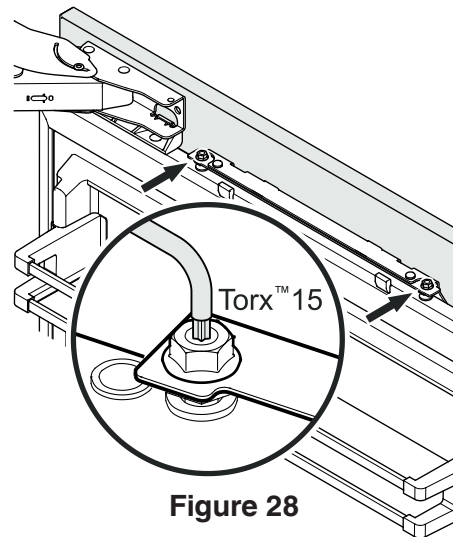

2. Open the refrigerator door and hang the panel on the top adjusting bolts (**Figure 27**).
3. Screw on the hex nuts to the adjusting bolts and finger tighten temporarily (**Figure 27**).

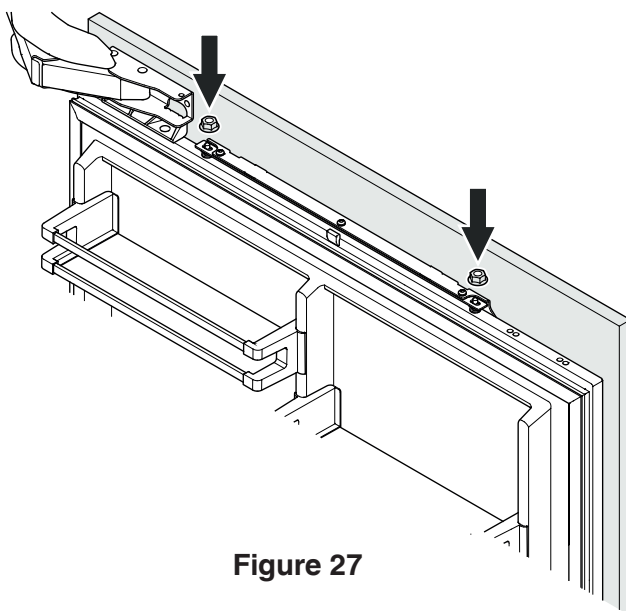

6. Align the panel horizontally (with the long holes in the attachment bracket) (**Figure 29**).
7. Tighten the hex nuts.

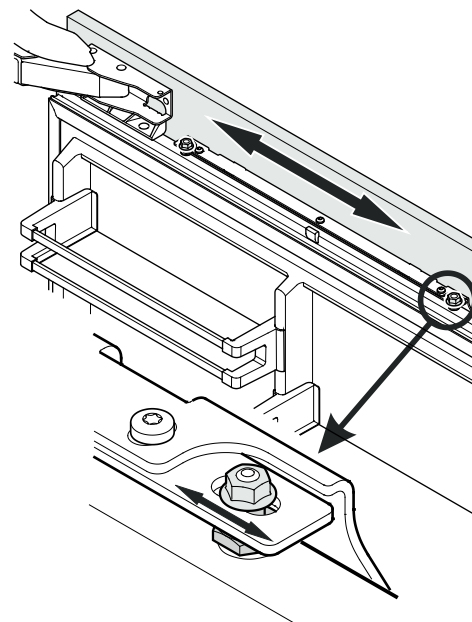

INSTALLATION

8. Turn the adjusting bolts (bottom refrigerator door) until they make contact with the attachment bracket (Figure 30).

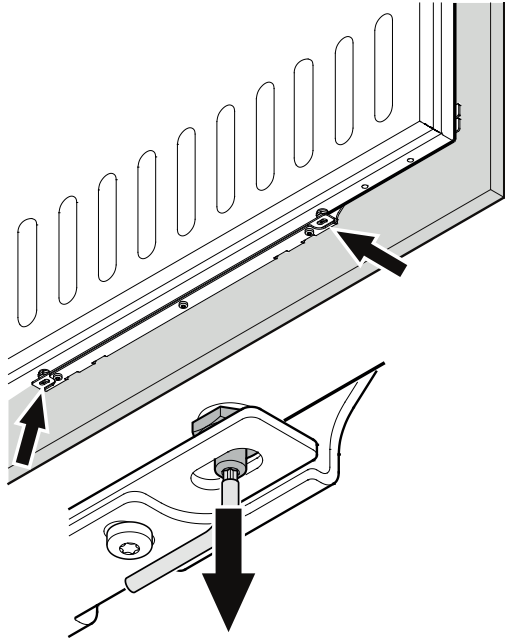

Figure 30

9. Screw on the hex nuts and tighten (Figure 31).

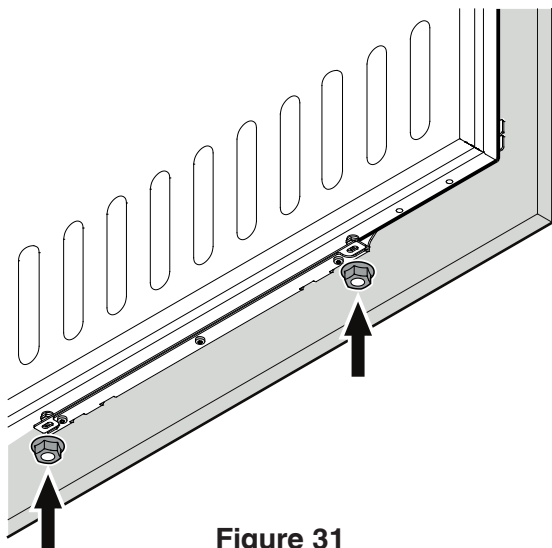

Figure 31

10. Loosen the three screws on the top of the attachment bracket, align the panel as shown in Figure 32 and tighten the screws. This can also be done with the lower attachment bracket.

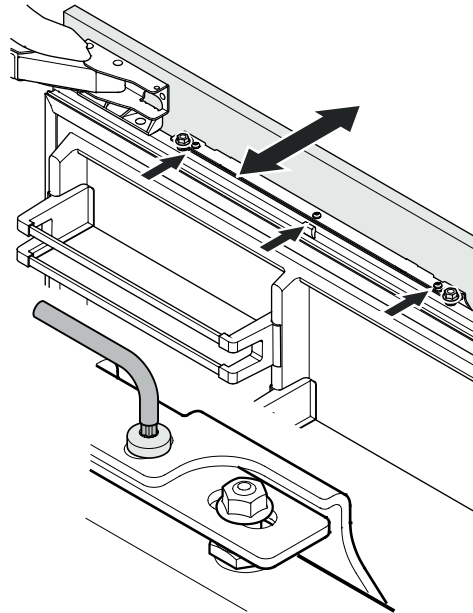

Figure 32

11. Click cover (1) into place. Insert the cover strip provided (2) between refrigerator door and panel (Figure 33).

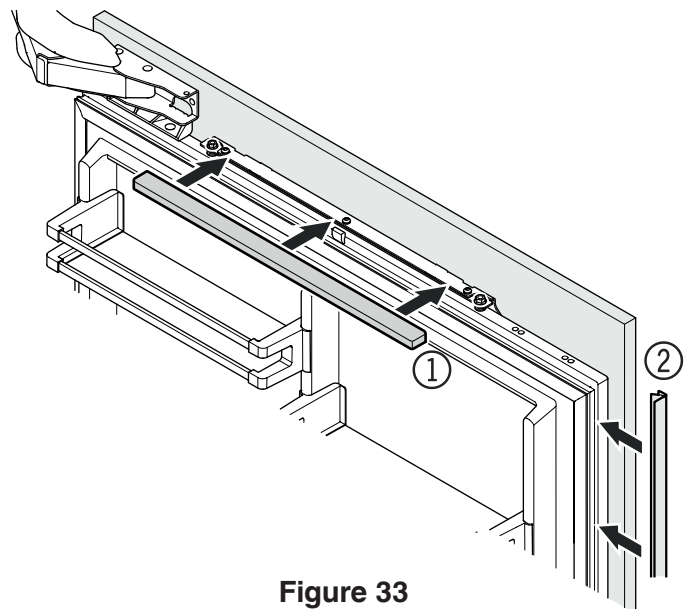

Figure 33

Mounting the Freezer Drawer Panels - Figure 34

1. Pull out the upper freezer drawer and screw on the panel with three screws at left and right hand side using the screws as shown in **Figure 34**.
2. Close the drawer and check the position to the surrounding cabinet panels. Align the panel in vertical direction by loosening the screws left and right. Finally tighten the screws.



CAUTION

Do not overtighten. Do not use a power driver.

3. Pull out the lower freezer drawer and fasten the lower panel in the same way.
4. Finally cover the gap between the drawer and the panel of both freezer drawers with the strips provided. Remove the foil from the adhesive surface of the strip and stick on the top of the appliance drawer making sure the flexible gasket is fully inserted in the gap.

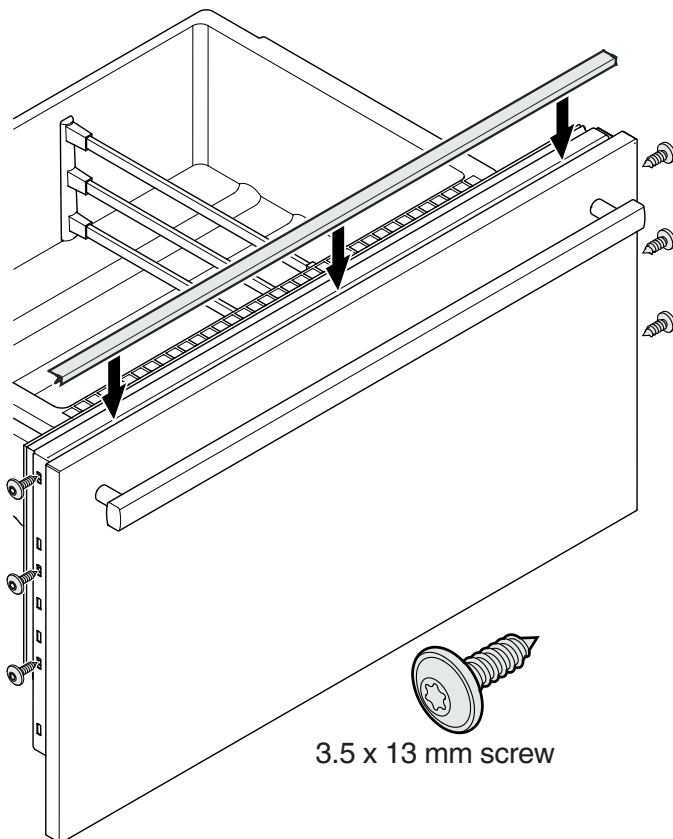

Figure 34

Mounting the Ventilation Grille - Figure 35, 36

1. Pull out the bottom freezer drawer.
2. Remove the blue protection film from the dust filter provided and insert the filter into its opening in the toe kick area as shown in **Figure 35**. Engage the filter at the bottom, press down the button and click into place.

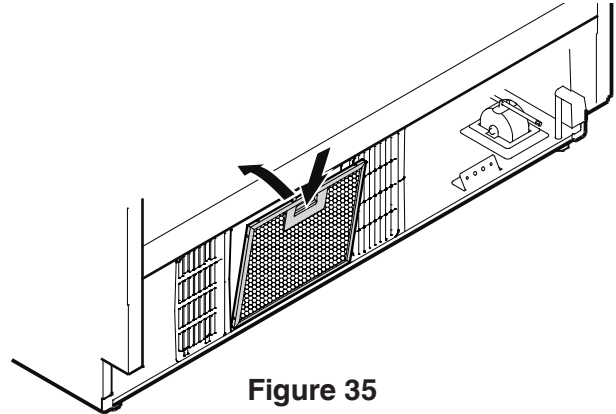

Figure 35

3. Mount the ventilation grille as shown in **Figure 36**.

IMPORTANT

Only use the ventilation grille provided with the appliance. This grille is required for proper operation of the appliance.

The ventilation opening must not be covered with a cabinet base.

Failure to use the supplied grille can result in product failure and will void the warranty.

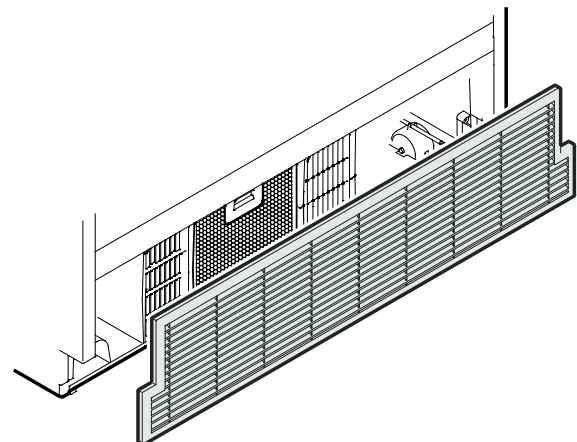

Figure 36

For Service in the U.S.

Liebherr Service Center

Toll Free: **1-866-LIEBHER** or **1-866-543-2437**

Email: Service-appliances.us@liebherr.com

PlusOne Solutions, Inc.

3501 Quadrangle Blvd, Suite 120

Orlando, FL 32817

For Service in Canada

Liebherr Service Center

Toll Free: **1-888-LIEBHER** or **1-888-543-2437**

www.euro-parts.ca

EURO-PARTS CANADA

39822 Belgrave Road

Belgrave, Ontario, N0G 1E0

Phone: (519) 357-3320

Fax: (519) 357-1326



www.liebherr-appliances.com