

USER GUIDE

SAFETY • INSTALLATION & INTEGRATION • OPERATING INSTRUCTIONS • MAINTENANCE • **SERVICE**

Parts

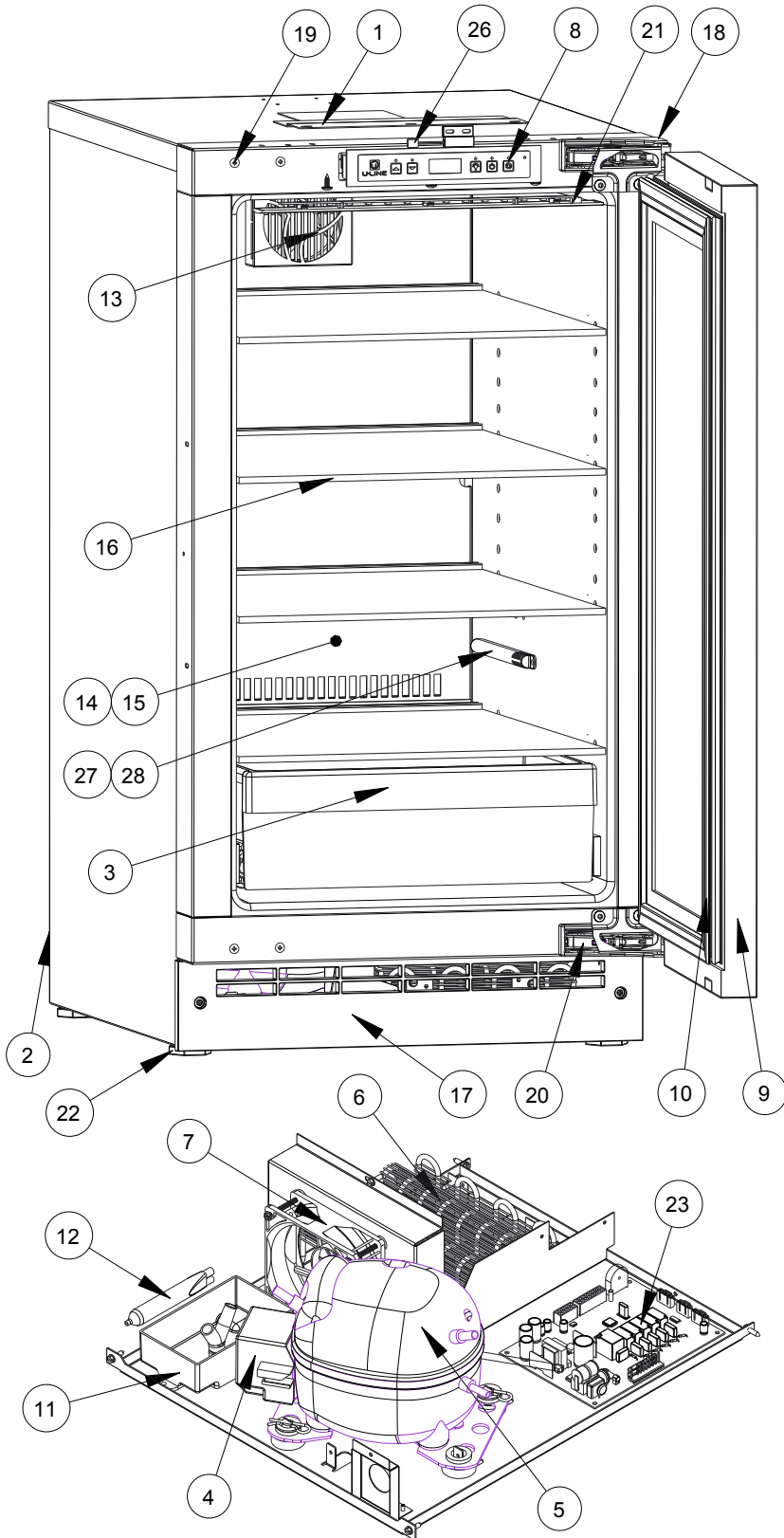

U-2218RINT-00B		
Item	Description	U-Line P/N
1	Anti tip bracket w/screws	80-54012-00
2	Back panel	80-54175-00
3	Crisper	80-54025-00
4	Compressor electricals only	80-54149-00
5	Compressor w/electricals	80-54150-00
6	Condenser	80-54022-00
7	Condenser fan w/screws	80-54014-00
8	Display module	80-54007-00
9	Door assembly w/o hinges	80-54174-00
10	Door gasket	80-54003-00
11	Drain pan w/double sided tape	80-54002-00
12	Drier	80-54055-00
13	Evap fan w/cover and screws	80-54151-00
14	Evaporator	80-54152-00
15	Evaporator cover	80-54021-00
16	Glass shelf (1) w/clips	80-54015-00
17	Grille w/screws	80-54011-00
18	Hinge covers(2 pcs)	80-54001-00
19	Hinge mounting hole covers	80-54024-00
20	Hinges(2) w/screws and covers	80-54013-00
21	LED light strip and cover assy	80-54000-00
22	Leg Levelers (4)	80-54019-00
23	Main board(no wires or case)	80-54008-00
24	Packaging	80-54143-00
25	Power cord	80-54171-00
26	Reed switch	80-54134-00
27	Thermistor (1 piece)	80-54006-00
28	Thermistor cover and pin	80-54023-00