



Ice Cream Display Freezers

***Models FR-CN-0667, 1016, 1245, 1473, 2007
Items 31455, 31456, 27941, 31457, 37815***

Instruction Manual



Revised - 05/29/2018



Toll Free: 1-800-465-0234
Fax: 905-607-0234
Email: service@omcan.com
www.omcan.com

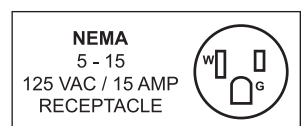

Table of Contents

Model FR-CN-0667 / Model FR-CN-1016 / Model FR-CN-1245
Model FR-CN-1473 / Model FR-CN-2007

Section	Page
General Information -----	3 - 4
Safety and Warranty -----	4 - 5
Technical Specifications -----	5
Installation -----	6
Operation -----	6
Maintenance -----	7
Troubleshooting -----	7 - 8
Parts Breakdown -----	9 - 13
Electrical Schematics -----	14 - 16
Notes -----	17 - 18
Warranty Registration -----	19



General Information

Omcan Manufacturing and Distributing Company Inc., Food Machinery of America, Inc. dba Omcan and Omcan Inc. are not responsible for any harm or injury caused due to any person's improper or negligent use of this equipment. The product shall only be operated by someone over the age of 18, of sound mind, and not under the influence of any drugs or alcohol, who has been trained in the correct operation of this machine, and is wearing authorized, proper safety clothing. Any modification to the machine voids any warranty, and may cause harm to individuals using the machine or in the vicinity of the machine while in operation.

CHECK PACKAGE UPON ARRIVAL

Upon receipt of an Omcan shipment please inspect for external damage. If no damage is evident on the external packaging, open carton to ensure all ordered items are within the box, and there is no concealed damage to the machine. If the package has suffered rough handling, bumps or damage (visible or concealed), please note it on the bill of lading before accepting the delivery and contact Omcan within 24 hours, so we may initiate a claim with the carrier. A detailed report on the extent of the damage caused to the machine must be filled out within three days, from the delivery date shown in the shipping documents. Omcan has no recourse for damaged products that were shipped collect or third party.

Before operating any equipment, always read and familiarize yourself with all operation and safety instructions.

Omcan would like to thank you for purchasing this machine. It's of the utmost importance to save these instructions for future reference. Also save the original box and packaging for shipping the equipment if servicing or returning of the machine is required.

Omcan Fabrication et distribution Compañie Limité et Food Machinery d'Amérique, dba Omcan et Omcan Inc. ne sont pas responsables de tout dommage ou blessure causé du fait que toute personne ait utilisé cet équipement de façon irrégulière. Le produit ne doit être exploité que par quelqu'un de plus de 18 ans, saine d'esprit, et pas sous l'influence d'une drogue ou d'alcool, qui a été formé pour utiliser cette machine correctement, et est vêtu de vêtements de sécurité approprié. Toute modification de la machine annule toute garantie, et peut causer un préjudice à des personnes utilisant la machine ou des personnes à proximité de la machine pendant son fonctionnement.

VÉRIFIEZ LE COLIS DÈS RÉCEPTION

Dès réception d'une expédition d'Omcan veuillez inspecter pour dommages externes. Si aucun dommage n'est visible sur l'emballage externe, ouvrez le carton afin de s'assurer que tous les éléments commandés sont dans la boîte, et il n'y a aucun dommage dissimulé à la machine. Si le colis n'a subi aucune mauvaises manipulations, de bosses ou de dommages (visible ou cachée), notez-le sur le bond de livraison avant d'accepter la livraison et contactez Omcan dans les 24 heures qui suivent, pour que nous puissions engager une réclamation auprès du transporteur. Un rapport détaillé sur l'étendue des dommages causés à la machine doit être rempli dans un délai de trois jours, à compter de la date de livraison indiquée dans les documents d'expédition. Omcan n'a aucun droit de recours pour les produits endommagés qui ont été expédiés ou cueilli par un tiers transporteur.

General Information

Avant d'utiliser n'importe quel équipement, toujours lire et vous familiariser avec toutes les opérations et les consignes de sécurité.

Omcan voudrais vous remercier d'avoir choisi cette machine. Il est primordial de conserver ces instructions pour une référence ultérieure. Également conservez la boîte originale et l'emballage pour l'expédition de l'équipement si l'entretien ou le retour de la machine est nécessaire.

Omcan Empresa De Fabricacion Y Distribucion Inc. Y Maquinaria De Alimentos De America, Inc. dba Omcan y Omcan Inc. no son responsables de ningun daño o perjuicio causado por cualquier persona inadecuada o el uso descuidado de este equipo. El producto solo podra ser operado por una persona mayor de 18 años, en su sano juicio y no bajo alguna influencia de droga o alcohol, y que este ha sido entrenado en el correcto funcionamiento de esta máquina, y ésta usando ropa apropiada y autorizada. Cualquier modificación a la máquina anula la garantía y puede causar daños a las personas usando la máquina mientras esta en el funcionamiento.

REVISE EL PAQUETE A SU LLEGADA

Tras la recepcion de un envio Omcan favor inspeccionar daños externos. Si no hay daños evidentes en el empaque exterior, Habra el carton para asegurarse que todos los articulos solicitados estén dentro de la caja y no encuentre daños ocultos en la máquina. Si el paquete ha sufrido un manejo de poco cuidado, golpes o daños (visible o oculto) por favor anote en la factura antes de aceptar la entrega y contacte Omcan dentro de las 24 horas, de modo que podamos iniciar una reclamación con la compañía. Un informe detallado sobre los daños causados a la máquina debe ser llenado en el plazo de tres días, desde la fecha de entrega que se muestra en los documentos de envío. Omcan no tiene ningun recurso por productos dañados que se enviaron a recoger por terceros.

Antes de utilizar cualquier equipo, siempre lea y familiarizarse con todas las instrucciones de funcionamiento y seguridad.

Omcan le gustaría darle las gracias por la compra de esta máquina. Es de la mayor importancia para salvar estas instrucciones para futuras consultas. Además, guarda la caja original y el embalaje para el envío del equipo si servicio técnico o devolución de la máquina que se requiere.

Safety and Warranty

1 YEAR PARTS AND LABOUR WARRANTY

Within the warranty period, contact Omcan Inc. at 1-800-465-0234 to schedule an Omcan authorized service technician to repair the equipment locally.

Unauthorized maintenance will void the warranty. Warranty covers electrical and part failures, not improper use.



Safety and Warranty

Please see www.omcan.com/warranty.html for complete info.

WARNING:

The packaging components are classified as normal solid urban waste and can therefore be disposed of without difficulty.

In any case, for suitable recycling, we suggest disposing of the products separately (differentiated waste) according to the current norms.

DO NOT DISCARD ANY PACKAGING MATERIALS IN THE ENVIRONMENT!

Technical Specifications

Model	FR-CN-0667	FR-CN-1016	FR-CN-1245	FR-CN-1473	FR-CN-2007
Freezer Capacity	160 L / 5.6 cu. ft.	260 L / 9.2 cu. ft.	360 L / 12.8 cu. ft.	500 L / 17.7 cu. ft.	700 L / 24.7 cu. ft.
Number of Doors	2				
Number of Baskets	2	3	4	5	7
Temperature Range	≤ -18°C / ≤ -0.4°F				
Refrigerant	R290				
Electrical	110 V / 60 Hz				
Weight	92.6 lbs. / 42 kgs.	125.7 lbs. / 57 kgs.	147.7 lbs. / 67 kgs.	176.3 lbs. / 80 kgs.	264.5 lbs. / 120 kgs.
Packaging Weight	108 lbs. / 49 kgs.	141.1 lbs. / 64 kgs.	167.6 lbs. / 76 kgs.	209.5 lbs. / 95 kgs.	308.5 lbs. / 140 kgs.
Dimensions	27.8" x 26.3" x 34.5" 706 x 668 x 876mm	27.8" x 39" x 34.5" 706 x 991 x 876mm	28" x 49" x 34" 711 x 1245 x 864mm	58" x 29.8" x 32.3" 1473 x 757 x 820mm	29.8" x 78.7" x 32.3" 757 x 1999 x 820mm
Packing Dimensions	30" x 29" x 37.5" 762 x 737 x 953mm	30" x 41.8" x 37.5" 762 x 1062 x 953mm	30" x 53" x 38" 762 x 1346 x 965mm	60" x 31.8" x 34.8" 1524 x 808 x 884mm	32" x 81" x 37" 813 x 2057 x 940mm
Item Number	31455	31456	27941	31457	37815

Installation

TRANSPORTATION AND PLACEMENT

- When transporting the chest freezer from one place to another, the inclination of the cabinet should not exceed 45 degrees, for prevention against compressor or system damage.
- Before use, remove all the packing material. The back side of the cabinet should be more than 20cm / 7.87" away from the wall, both flank sides more than 20cm / 7.87".
- The freezer should be put in well-ventilated, dry place. Don't use it under direct sunshine. The freezer should be kept away from water sink, heat source and any volatile, corrosive material.

Operation

POWER SOURCE AND TEST-RUNNING

- Specified capacity of the wire is 6A. Section squares of the wire is 0.75mm. Single line or compound lines are all allowed. The fuse of 2.5A specified electric current should be installed. (Power cord should be replaced with the same of 6A and 0.75mm, when it is damaged).
- Single-phase power supply, 60Hz, voltage 110V. If the voltage is unstable, please install a voltage stabilizer with capacity above 1000W.
- Avoid turning on and off the power too frequently. If the power is turned off, wait an interval of 5 minutes before turning it on again.
- When the freezer will be out of use for a long time, disconnect the power first, then clean it. Please examine the circuit whether it is excellent before reuse.

OPERATION OF THE TEMPERATURE CONTROL KNOB

- The temperature in the cabinet can be controlled with the temperature control knob.
- The knob should be kept upright normally to adjust the temperature. FREEZING MAX is the strongest cooling position and is suitable for fast freezing. Do not keep the knob at this point for long.

FOOD STORAGE

- There must be space between the foods stored in the cabinet, between the foods and the inner surface of the cabinet, so as to keep good ventilation of cold air and freeze evenly. Do not put in any bottled or canned beverage with freezing point above the temperature in the cabinet when it is below zero.
- For foods that should be moisture-free or lose water easily, wrap them up with hermetic food bags or fresh films before putting in the cabinet for the sake of avoiding smell-mixing and reducing frosting.
- Storage of volatile and combustible gases, liquids such as strong alkalies, strong acids, petrol, etc. is forbidden.

Maintenance

- The freezer should be cleaned regularly. When cleaning, turn off the power, take out the foods in the cabinet, clean the inside using water or a little neutral detergent.
 - Do not use boiling water, acid, chemical diluters, petrol and oil, or dirt-removing powder.
 - Dry it after cleaning.
 - Use light soap water when cleaning the door seal, apply a little of talcum powder on it after natural drying to extend its service life.
 - Use soft cloth with water or a little detergent to clean the out surface.
- Note, keeping the power supply and lower part of connect wires away from water to avoid electricity leakage.**
- Except common breakdowns, those who are not service technician should not take apart and repair the freezer on their own so as to avoid worsening the trouble. Unauthorized repair of electrical part such as compressor, temperature controller is forbidden.

DEFROSTING

- Defrost for better freezing efficiency when the frost film in the cabinet is 4-5mm thick.
- When defrosting, turn off the power, take out the frozen foods, open the door for warming and melting. Use soft cloth to absorb water and clean it up.
- Do not use sharp metal tools such as steel brush to clean the frost film when defrosting so as to avoid evaporator damage.

Troubleshooting

Symptom	Cause	Solution
The indicator is not on or the compressor does not start.	The plug isn't connected to the socket.	Re-connect it.
	No power.	Connect to a socket with power.
The indicator is on, but the compressor doesn't work and buzzes only.	The power voltage is <110V.	Attach a power-regulator with more than 1000W power.
The compressor stops a minute after start, and restart after a few minutes, and so repeatedly.	The power voltage is >110V.	

Troubleshooting

The compressor works normally, but the temperature in the cabinet cools too slowly.	The door is being opened too frequently.	Reduce open times.
	The is too much food in the cabinet, and it is placed improperly.	Place food properly, keep space between them for ventilation of cold air.
	The frost film is too thick.	Take out food and defrost.
	The surface of the condenser is too dirty.	Stop and clean the condenser.
	The door doesn't seal.	Adjust the door seal.
The noise is too loud.	The freezer is placed in a unstable location.	Place it in a stable location.
	The fixing of the freezer is loose.	Tighten the fixing.
	There's contact between pipes.	Separate the pipes.

THE FOLLOWING ARE WITHIN NORMAL OPERATING PARAMETERS:

- When the freezer is working or after is stops for a while, the refrigerant in the pipes is cycling and gives out "running water" sounds.
- The surface temperature of the compressor may be up 70°C ~ 80°C / 158°F ~ 176°F when it is working.
- The back side of step freezer gives out heat.
- In rainy season, the outer surface of the cabinet may have dew, which makes no defects on normal use. Just dry it with a piece of cloth.

For service call 1-800-465-0234.

REFERENCE

Item Number	Model Number	Description	Manufacturer Model Number
31455	FR-CN-0667	Freezer Ice Cream Reach In 26" / 667mm 110V/60/1 ETL cETLus	XS150YX
31456	FR-CN-1016	Freezer Ice Cream Reach In 39" / 991mm 110V/60/1 ETL cETLus	XS260YX
27941	FR-CN-1245	Freezer Ice Cream Reach In 49" / 1245mm 110V/60/1 ETL cETLus	XS360YX
31457	FR-CN-1473	Freezer Ice Cream Reach In 58" / 1473mm 110V/60/1 ETL cETLus	XS500BY
37815	FR-CN-2007	Freezer Ice Cream Reach In 79" / 2007mm 110V/60/1 ETL cETLus	XS700BY

Parts Breakdown

Model FR-CN-0667 31455

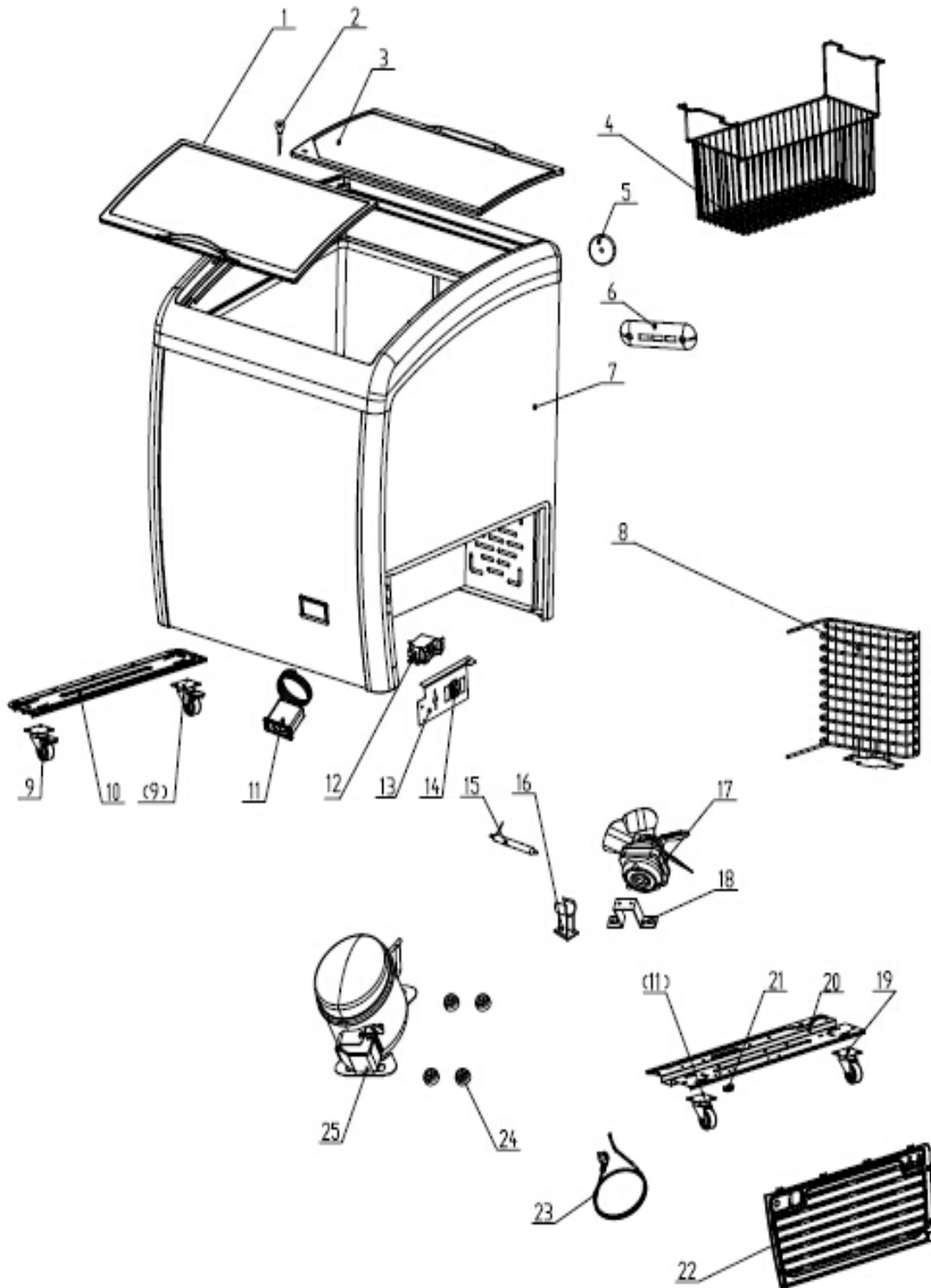

Parts Breakdown

Model FR-CN-1016 31456

Model FR-CN-1245 27941

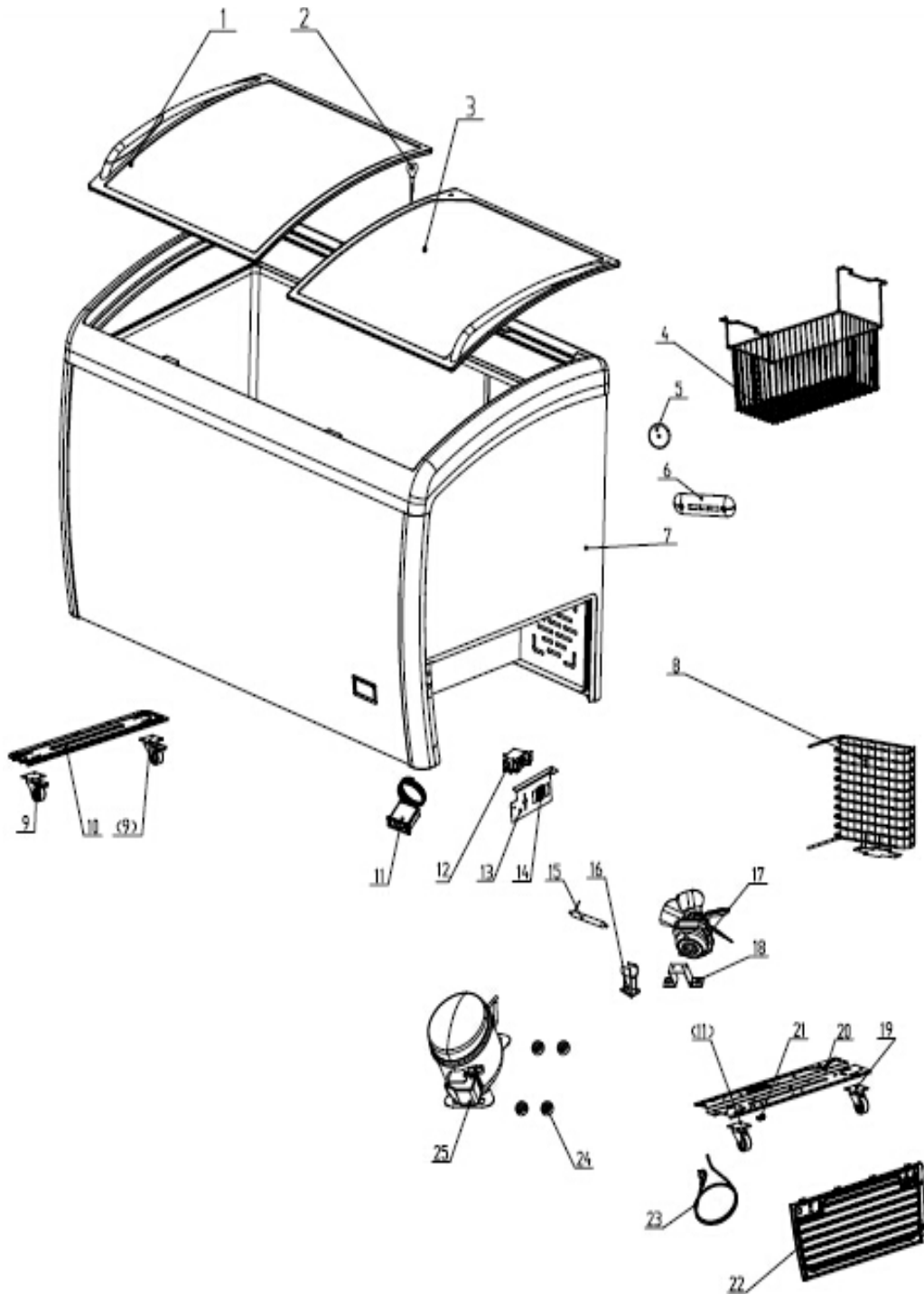

Parts Breakdown

Model FR-CN-1473 31457

Model FR-CN-2007 37815

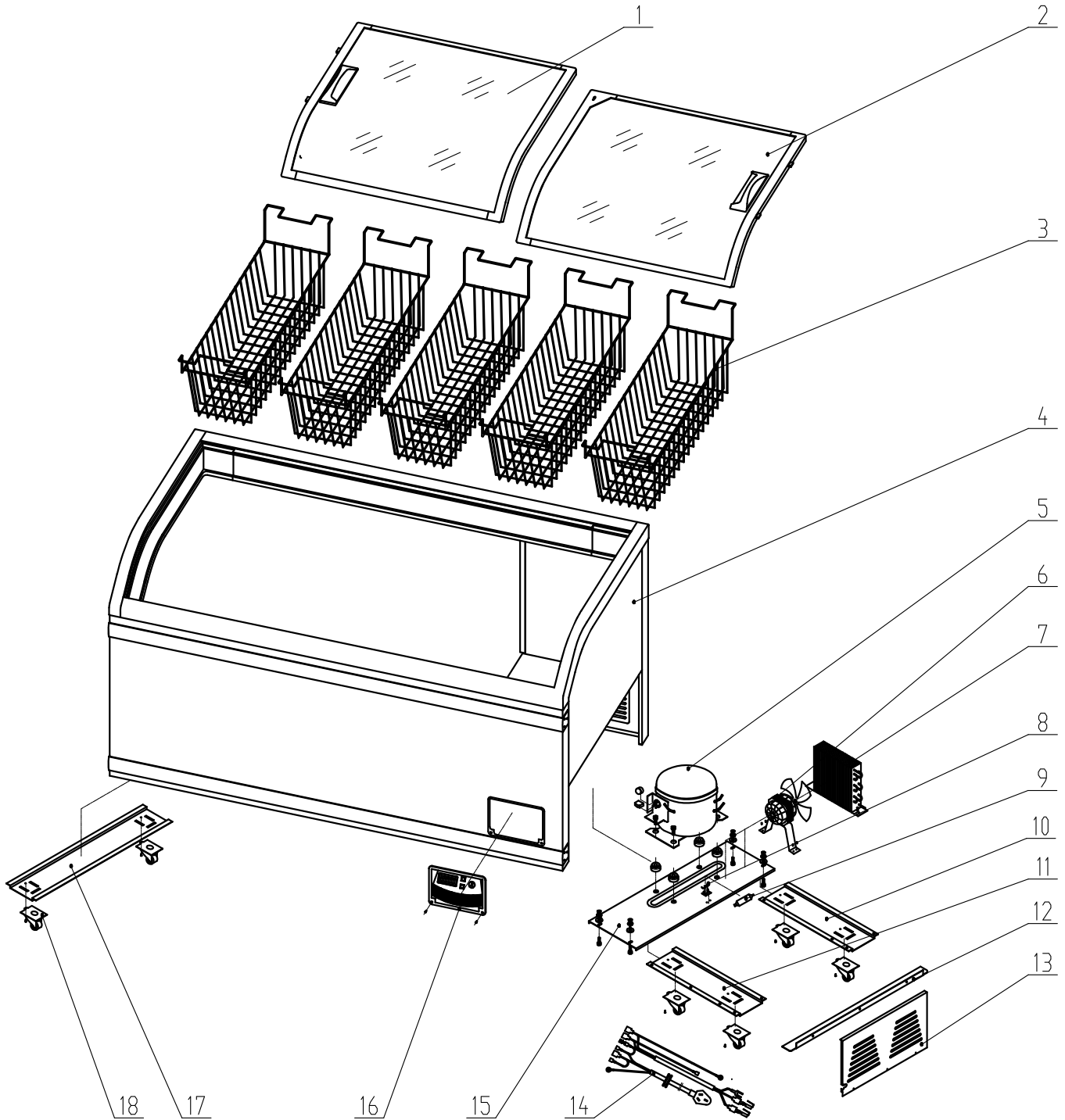

Parts Breakdown

Model FR-CN-0667 31455

Item No.	Description	Position	Item No.	Description	Position	Item No.	Description	Position
37875	Upper Glass Door for XS150YX	1	78718	Castor Channel Iron A for XS150YX	10	64768	Fan Motor Support for XS150YX	18
41162	Key with Lock for XS150YX	2	78719	Castor Channel Iron B for XS150YX	10	28446	Castor without Brake for XS150YX	19
28442	Lower Glass Door for XS150YX	3	64765	Thermometer for XS150YX	11	78720	Compressor Support for XS150YX	20
31440	Basket for XS150YX	4	28449	Thermostat for XS150YX	12	28447	Side Panel for XS150YX	22
64763	Thermostat Cover for XS150YX	5	64766	Thermostat Support for XS150YX	13	28448	Power Cord for XS150YX	23
64764	Thermometer Cover for XS150YX	6	39587	Indicator Lamp for XS150YX	14	28450	Compressor for XS150YX	25
64769	Cabinet for XS150YX	7	39586	Filter for XS150YX	15	63504	Compressor (R290) for XS150YX	25
28453	Condenser for XS150YX	8	64441	Filter Support for XS150YX	16	43413	Basket Divider for XS150YX	
28445	Castor with Brake for XS150YX	9	64767	Fan Motor for XS150YX	17			

Model FR-CN-1016 31456

Item No.	Description	Position	Item No.	Description	Position	Item No.	Description	Position
28443	Left Glass Door for XS260YX	1	78718	Castor Channel Iron A for XS260YX	10	64768	Fan Motor Support for XS260YX	18
41162	Key with Lock for XS260YX	2	78719	Castor Channel Iron B for XS260YX	10	28446	Castor without Brake for XS260YX	19
39817	Right Glass Door for XS260YX	3	64765	Thermometer for XS260YX	11	78720	Compressor Support for XS260YX	20
31440	Basket for XS260YX	4	28449	Thermostat for XS260YX	12	28447	Side Panel for XS260YX	22
64763	Thermostat Cover for XS260YX	5	64766	Thermostat Support for XS260YX	13	28448	Plug for XS260YX	23
64764	Thermometer Cover for XS260YX	6	39587	Indicator Lamp for XS260YX	14	28451	Compressor for XS260YX	25
64770	Cabinet for XS260YX	7	39586	Filter for XS260YX	15	63506	Compressor (R290) for XS260YX	25
37874	Condenser for XS260YX	8	64441	Filter Support for XS260YX	16	43413	Basket Divider for XS260YX	
28445	Castor with Brake for XS260YX	9	64771	Fan Motor for XS260YX	17			

Model FR-CN-1245 27941

Item No.	Description	Position	Item No.	Description	Position	Item No.	Description	Position
28444	Left Glass Door for XS360YX	1	78718	Castor Channel Iron A for XS360YX	10	64768	Fan Motor Support for XS360YX	18
41162	Key with Lock for XS360YX	2	78719	Castor Channel Iron B for XS360YX	10	28446	Castor without Brake for XS360YX	19
39777	Right Glass Door for XS360YX	3	64765	Thermometer for XS360YX	11	78720	Compressor Support for XS360YX	20
31440	Basket for XS360YX	4	28449	Thermostat for XS360YX	12	28447	Side Panel for XS360YX	22
64763	Thermostat Cover for XS360YX	5	64766	Thermostat Support for XS360YX	13	28448	Plug for XS360YX	23
64764	Thermometer Cover for XS360YX	6	39587	Indicator Lamp for XS360YX	14	28452	Compressor for XS360YX	25
64772	Cabinet for XS360YX	7	39586	Filter for XS360YX	15	63503	Compressor (R290) for XS360YX	25
37874	Condenser for XS360YX	8	64441	Filter Support for XS360YX	16	43413	Basket Divider for XS360YX	
28445	Castor with Brake for XS360YX	9	28454	Fan Motor for XS360YX	17			

Parts Breakdown

Model FR-CN-1473 31457

Item No.	Description	Position	Item No.	Description	Position	Item No.	Description	Position
28455	Left Glass Door for XS500BY	1	28459	Condenser for XS500BY	7	28465	Shutter for XS500BY	13
40162	Right Glass Door for XS500BY	2	28460	Filter Support for XS500BY	8	28466	Power Cable for XS500BY	14
28456	Basket for XS500BY	3	28461	Filter for XS500BY	9	28467	Compressor Support for XS500BY	15
28457	Compressor (R134a) for XS500BY	5	28462	Castor Channel Iron A for XS500BY	10	28468	Thermostat for XS500BY	16
63505	Compressor (R290) for XS500BY	5	28463	Castor Channel Iron B for XS500BY	11	76709	Castor Channel Iron for XS500BY	17
28458	Cooling Fan for XS500BY	6	28464	Iron Liner for XS500BY	12	28469	Castor for XS500BY	18

Model FR-CN-2007 37815

Item No.	Description	Position	Item No.	Description	Position	Item No.	Description	Position
40164	Left Glass Door for XS700BY	1	76699	Condenser for XS700BY	7	76705	Shutter for XS700BY	13
40163	Right Glass Door for XS700BY	2	76700	Filter Support for XS700BY	8	76706	Power Cable for XS700BY	14
76695	Basket for XS700BY	3	76701	Filter for XS700BY	9	76707	Compressor Support for XS700BY	15
28452	Compressor (R134a) for XS700BY	5	76702	Castor Channel Iron A for XS700BY	10	76708	Thermostat for XS700BY	16
63503	Compressor (R290) for XS700BY	5	76703	Castor Channel Iron B for XS700BY	11	76709	Castor Channel Iron for XS700BY	17
76698	Cooling Fan for XS700BY	6	76704	Iron Liner for XS700BY	12	76710	Castor for XS700BY	18

Electrical Schematics

Model FR-CN-0667 31455

Model FR-CN-1016 31456

Model FR-CN-1245 27941

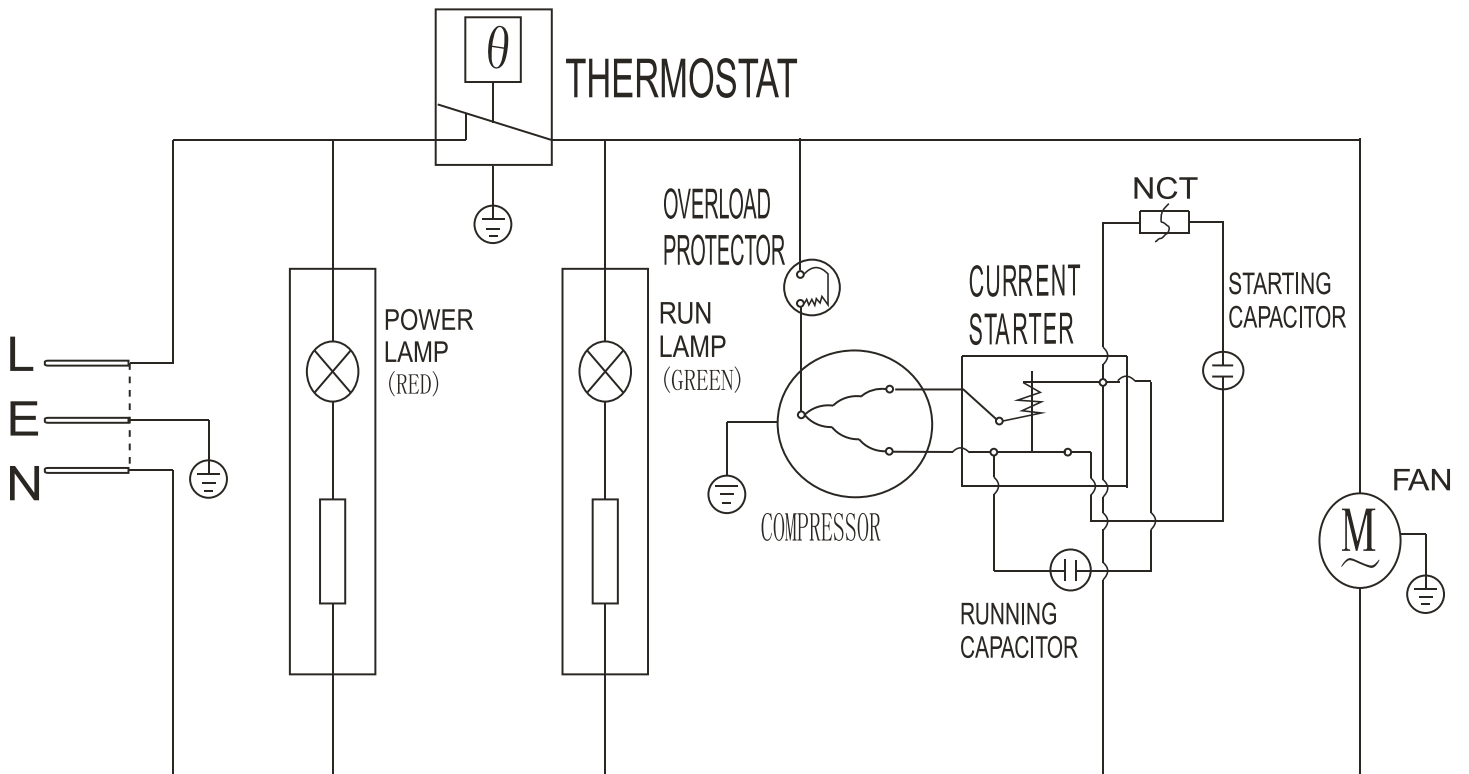

Electrical Schematics

Model FR-CN-1473 31457

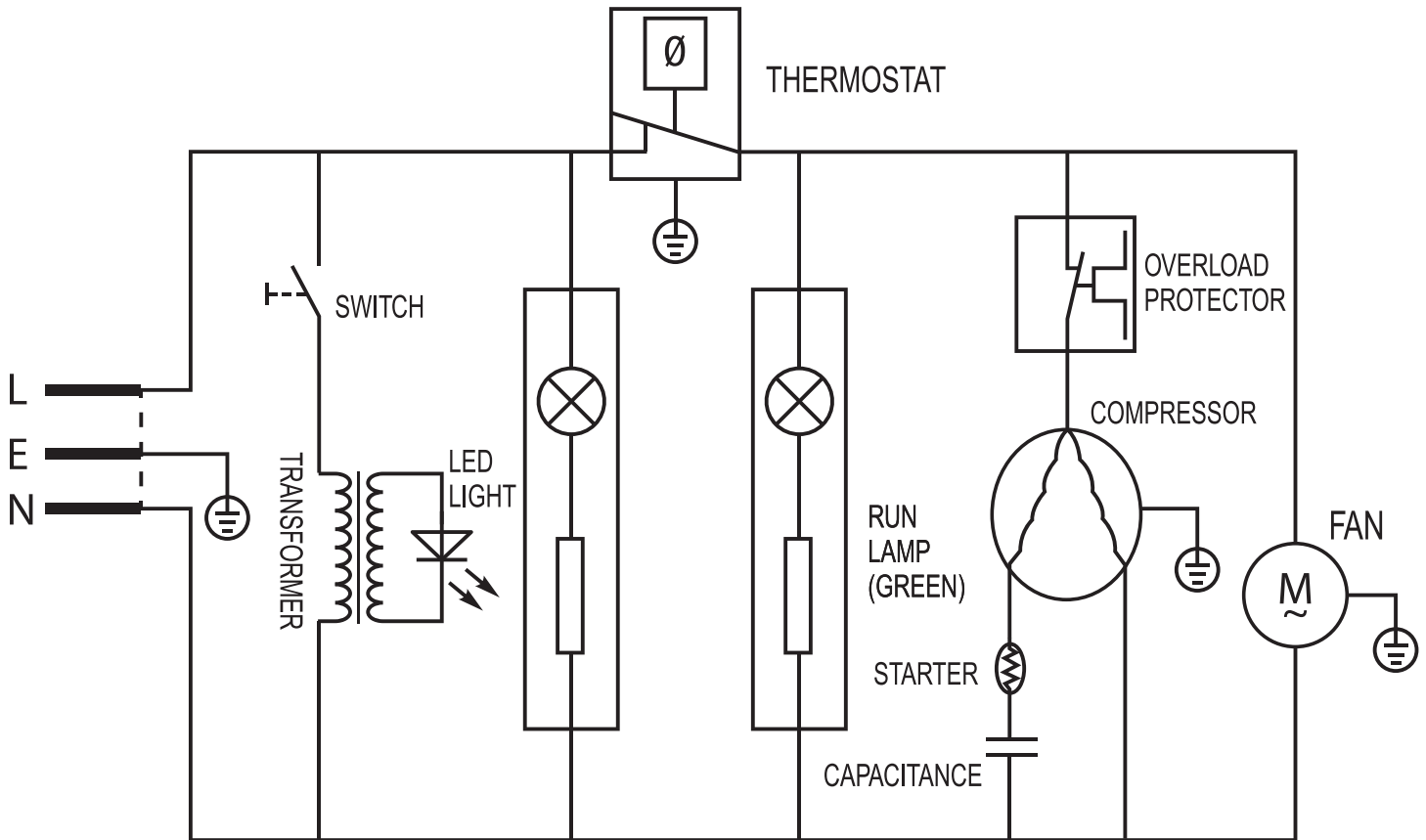

Electrical Schematics

Model FR-CN-2007 37815

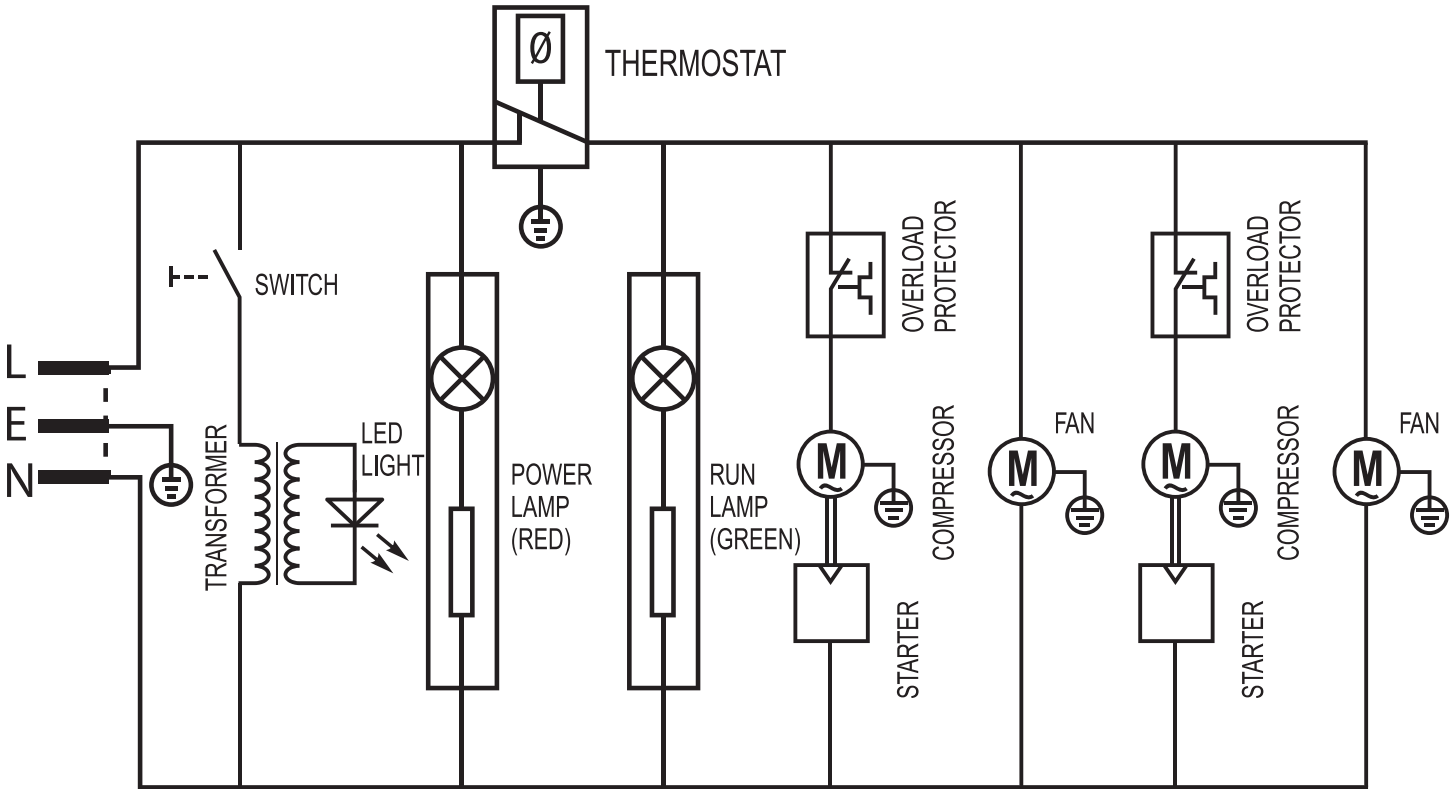



Warranty Registration

Thank you for purchasing an Omcan product. To register your warranty for this product, complete the information below, tear off the card at the perforation and then send to the address specified below. You can also register online by visiting:

Merci d'avoir acheté un produit Omcan. Pour enregistrer votre garantie pour ce produit, complétez les informations ci-dessous, détachez la carte au niveau de la perforation, puis l'envoyer à l'adresse spécifiée ci-dessous. Vous pouvez également vous inscrire en ligne en visitant:

Gracias por comprar un producto Omcan usted. Para registrar su garantía para este producto, complete la información a continuación, cortar la tarjeta en la perforación y luego enviarlo a la dirección indicada a continuación. También puede registrarse en línea en:

www.omcan.com/warrantyregistration.html

For mailing in Canada

Pour postale au Canada

Por correo en Canadá

OMCAN

PRODUCT WARRANTY REGISTRATION

3115 Pepper Mill Court,

Mississauga, Ontario

Canada, L5L 4X5

For mailing in the US

Pour diffusion aux États-Unis

Por correo en los EE.UU.

OMCAN

PRODUCT WARRANTY REGISTRATION

4450 Witmer Industrial Estates, Unit 4,

Niagara Falls, New York

USA, 14305

or email to: service@omcan.com



Purchaser's Information

Name: _____

Address: _____

City: _____ Province or State: _____ Postal or Zip: _____

Country: _____

Dealer from which Purchased: _____

Dealer City: _____ Dealer Province or State: _____

Invoice: _____

Model Name: _____ Model Number: _____

Machine Description: _____

Date of Purchase (MM/DD/YYYY): _____

Would you like to extend the warranty? Yes No

Company Name: _____

Telephone: _____

Email Address: _____

Type of Company:

Restaurant Bakery Deli

Butcher Supermarket Caterer

Institution (*specify*): _____

Other (*specify*): _____

Serial Number: _____

Date of Installation (MM/DD/YYYY): _____

Thank you for choosing Omcan | Merci d'avoir choisi Omcan | Gracias por elegir Omcan



Since 1951 Omcan has grown to become a leading distributor of equipment and supplies to the North American food service industry. Our success over these many years can be attributed to our commitment to strengthen and develop new and existing relationships with our valued customers and manufacturers. Today with partners in North America, Europe, Asia and South America, we continually work to improve and grow the company. We strive to offer customers exceptional value through our qualified local sales and service representatives who provide convenient access to over 3,500 globally sourced products.

Depuis 1951 Omcan a grandi pour devenir un des “leaders” de la distribution des équipements et matériel pour l’industrie des services alimentaires en Amérique du Nord. Notre succès au cours de ces nombreuses années peut être attribué à notre engagement à renforcer et à développer de nouvelles et existantes relations avec nos clients et les fabricants de valeur. Aujourd’hui avec des partenaires en Amérique du Nord, Europe, Asie et Amérique du Sud, nous travaillons continuellement à améliorer et développer l’entreprise. Nous nous efforçons d’offrir à nos clients une valeur exceptionnelle grâce à nos ventes locales qualifiées et des représentants de service qui offrent un accès facile à plus de 3500 produits provenant du monde entier.

Desde 1951 Omcan ha crecido hasta convertirse en un líder en la distribución de equipos y suministros de alimentos en América del Norte industria de servicios. Nuestro éxito en estos años se puede atribuir a nuestro compromiso de fortalecer y desarrollar nuevas relaciones existentes con nuestros valiosos clientes y fabricantes. Hoy con socios de América del Norte, Europa, Asia y América del Sur, que trabajan continuamente para mejorar y crecer la empresa. Nos esforzamos por ofrecer a nuestros clientes valor excepcional a través de nuestro local de ventas y representantes de los servicios que proporcionan un fácil acceso a más de 3,500 productos con origen a nivel mundial.

