



HOUSING Metal/Aluminum
IMPELLER Aluminum, Ø30mm
BEARING Ball or Sleeve
INSULATION Class A
OPERATING TEMPERATURE 0°C to + 45°C
OPERATING VOLTAGE RANGE 85 VAC to 125 VAC for 115V Type
 185 VAC to 245 VAC for 230V Type
DIELECTRIC STRENGTH 1,500 VAC for 1 second
INSULATION RESISTANCE 10M Ω min. @500 VDC
SAFETY Impedance Protected
MOTOR TYPE Shaded Pole Motor
ROHS COMPLIANCE Yes
IP LEVEL IP21 (Special IP Rating On Request)

* FAN IS FOR HORIZONTAL USE ONLY *

30mm

30 mm

DIMENSION

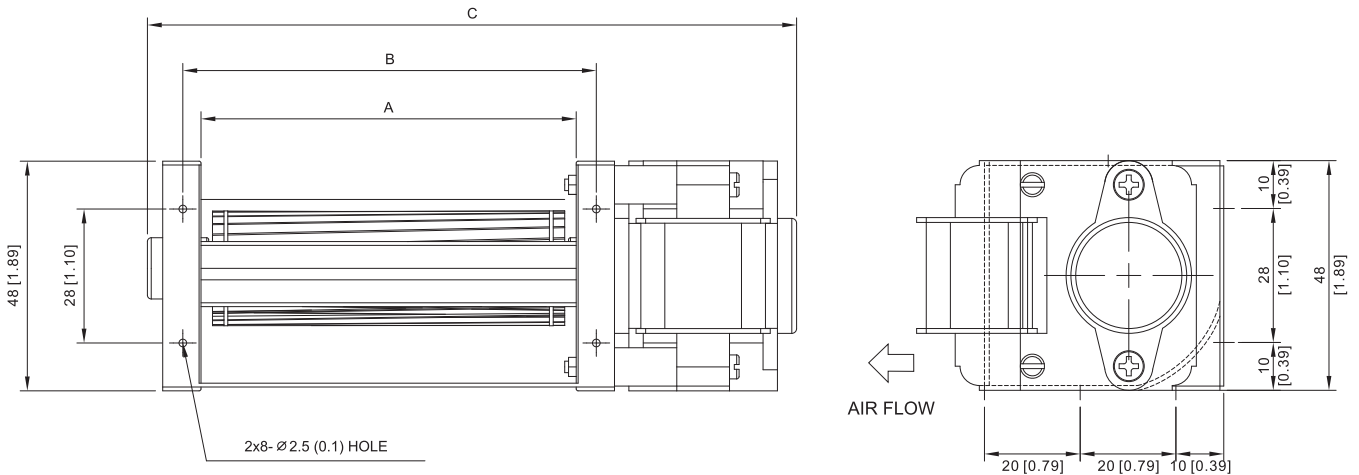

MODEL NO.	DIMENSION(mm)			WEIGHT (g)
	A	B	C	
sAFS30098	98	108	154	390
sAFS30160	160	170	222	520
sAFS30198	198	208	260	540
sAFS30300	300	310	366	670

UNIT:mm[inch]

SPECIFICATION

MODEL NO.	RATED VOLTAGE(V)	FREQUENCY (Hz)	RATED CURRENT(A)	INPUT POWER (W)	SPEED (RPM)	MAX. AIR PRESSURE		MAX. AIR FLOW		NOISE dB(A)@ 1M
						inchH ₂ O	mmH ₂ O	CFM	m ³ /min	
sAFS30098V1H	120	50/60	0.11/0.09	8/7	2500/2900	0.03/0.04	0.8/1.1	14/17	0.4/0.5	21/24
sAFS30098V2H	230	50/60	0.07/0.05	8/7	2500/2900	0.03/0.04	0.8/1.1	14/17	0.4/0.5	21/24
sAFS30160V1H	120	50/60	0.14/0.12	9/8	2700/3100	0.04/0.05	0.9/1.2	24/28	0.7/0.8	27/30
sAFS30160V2H	230	50/60	0.09/0.07	10/9	2700/3100	0.04/0.05	0.9/1.2	24/28	0.7/0.8	27/30
sAFS30198V1H	120	50/60	0.14/0.12	9/8	2700/3100	0.04/0.05	1.0/1.3	32/35	0.9/1.0	27/30
sAFS30198V2H	230	50/60	0.09/0.07	11/9	2700/3100	0.04/0.05	1.0/1.3	32/35	0.9/1.0	27/30
sAFS30300V1H	120	50/60	0.20/0.17	15/13	2700/3100	0.06/0.07	1.4/1.7	53/60	1.5/1.7	32/34
sAFS30300V2H	230	50/60	0.09/0.07	12/11	2700/3100	0.06/0.07	1.4/1.7	53/60	1.5/1.7	32/34

AIR PERFORMANCE

