

sDF

30

Ø30mm(Ø1.18")

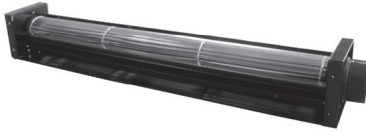

HOUSING Metal/Aluminum
 IMPELLER Aluminum, Ø30mm
 BEARING Ball
 OPERATING TEMPERATURE 0°C to + 45°C
 DIELECTRIC STRENGTH 5mA Max. at 500 VAC for 1 minute
 INSULATION RESISTANCE 10M Ω min. @500 VDC
 MOTOR TYPE DC Brushless Motor
 ROHS COMPLIANCE Yes
 IP LEVEL IP21 (Special IP Rating On Request)

* FAN IS FOR HORIZONTAL USE ONLY *

30

mm

30 mm

DIMENSION

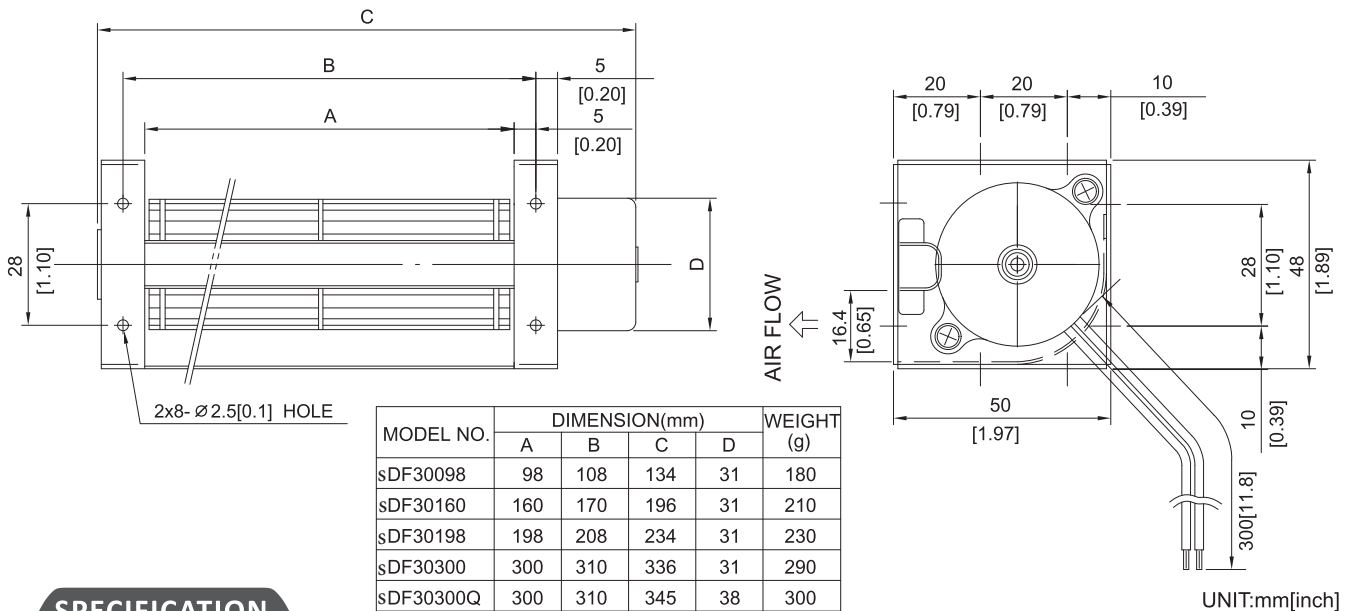

SPECIFICATION

MODEL NO.	RATED VOLTAGE(V)	RATED CURRENT(A)	INPUT POWER (W)	SPEED (RPM)	MAX. AIR PRESSURE		MAX. AIR FLOW		NOISE dB(A)@ 1M
					inchH ₂ O	mmH ₂ O	CFM	m ³ /min	
sDF30098V12H	12	0.15	1.80	3200	0.08	1.9	22	0.6	35
sDF30098V24H	24	0.18	4.32	3200	0.08	1.9	22	0.6	38
sDF30160V12H	12	0.16	1.92	3100	0.07	1.7	28	0.8	35
sDF30160V24H	24	0.15	3.60	3100	0.07	1.7	28	0.8	37
sDF30198V12H	12	0.20	2.40	2900	0.07	1.7	35	1.0	35
sDF30198V24H	24	0.16	3.84	2900	0.07	1.7	35	1.0	38
sDF30300V12H	12	0.22	2.64	2600	0.06	1.5	46	1.3	36
sDF30300V24H	24	0.20	4.80	2600	0.06	1.5	46	1.3	39
sDF30300V12HQ	12	0.28	3.36	2800	0.06	1.6	53	1.5	52
sDF30300V24HQ	24	0.15	3.60	2800	0.06	1.6	53	1.5	52

AIR PERFORMANCE

