

13391

Φ133x91MM

General Specifications

- ◆ Material..... Pillow: Die-Cast Aluminum
Impeller: Plastic (UL94V-0)
Lead Wire: UL1007AWG#20 or Equivalent (+) Red, (-) Black
- ◆ Expected Life..... Ball Bearing 50,000hrs (40°C)
- ◆ Temperature Range.... Operating temperature -10°C~70°C (Non-condensing)
Storage temperature -40°C~70°C (Non-condensing)
- ◆ Safety Standards..... UL, TUV, RoHS, CE
- ◆ DC Fan Specials..... RD, FG, PWM, Temperature control, IP56



Specifications

Model	#Bearing Type	Rated Voltage	Operating Voltage	Input Current	Input Power	Speed	Max Air Flow		Max Static Pressure		Noise	Weight
Part No.	B.S	VDC	VDC	Amp	Watt	RPM	CFM	m ³ /min	Inch-H ₂ O	Pa	dB-A	g
sDCF13391V24 U	B	24	14.0~27.6	2.55	62.00	5000	264.85	7.50	2.39	595.26	69.0	680.0
sDCF13391V24 H	B	24	14.0~27.6	1.50	36.00	4000	211.88	6.00	1.56	380.80	64.0	680.0
sDCF13391V24 M	B	24	14.0~27.6	0.75	18.00	3000	158.91	4.50	0.86	214.23	58.0	680.0
sDCF13391V24 L	B	24	14.0~27.6	0.50	8.00	2000	105.94	3.00	0.38	95.21	49.0	680.0
sDCF13391V48 U	B	48	28.0~56.0	1.25	62.00	5000	264.85	7.50	2.39	595.26	69.0	680.0
sDCF13391V48 H	B	48	28.0~56.0	0.80	36.00	4000	211.88	6.00	1.56	380.80	64.0	680.0
sDCF13391V48 M	B	48	28.0~56.0	0.40	18.00	3000	158.91	4.50	0.86	214.23	58.0	680.0
sDCF13391V48 L	B	48	28.0~56.0	0.15	8.00	2000	105.94	3.00	0.38	95.21	49.0	680.0

Specifications are subject to change without notice. Please visit our website at <http://www.sofasco.com> for update information

Dimensions (Unit:mm)

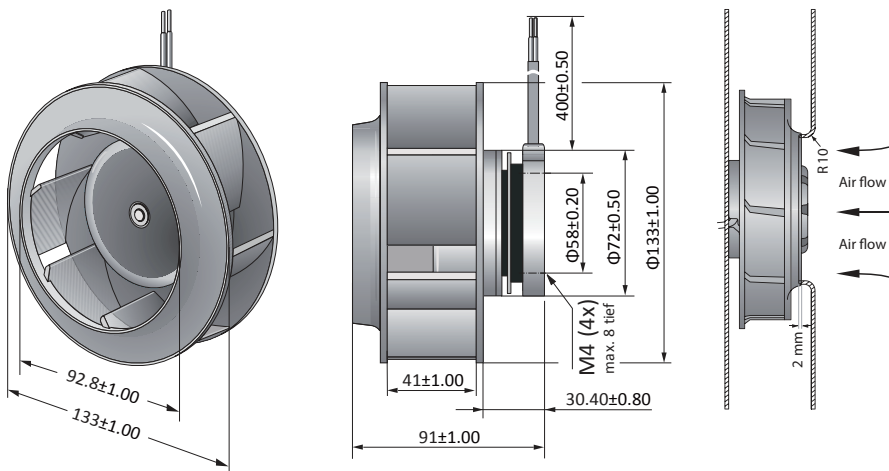

PQ Curve (At rated Voltage)

