

9733

97x97x33MM

General Specifications

- ◆ Material..... Frame: Plastic (UL94V-0)
Impeller: Plastic (UL94V-0)
Lead Wire: UL1007AWG#24 or Equivalent (+) Red, (-) Black
- ◆ Expected Life..... Ball Bearing 70,000hrs (40°C)
Sleeve Bearing 30,000hrs (40°C)
- ◆ Temperature Range.... Operating temperature -10°C~70°C (Non-condensing)
Storage temperature -40°C~70°C (Non-condensing)
- ◆ Safety Standards..... UI, TUV, RoHS, CE
- ◆ DC Fan Specials..... RD, FG, PWM, Temperatrue control, IP56



Specifications

Model	#Bearing Type	Rated Voltage	Operating Voltage	Input Current	Input Power	Speed	Max Air Flow		Max Static Pressure		Noise	Weight
Part No.	B.S	VDC	VDC	Amp	Watt	RPM	CFM	m ³ /min	Inch-H ₂ O	Pa	dB-A	g
sDB9733V12U	B.S	12	7.0~13.8	1.40	16.80	4500	29.76	0.84	1.35	336.96	57.0	164.0
sDB9733V12H	B.S	12	7.0~13.8	1.00	12.00	4000	26.62	0.75	1.15	286.75	53.0	164.0
sDB9733V12M	B.S	12	7.0~13.8	0.60	7.20	3500	23.34	0.66	0.83	206.33	49.0	164.0
sDB9733V12L	B.S	12	7.0~13.8	0.40	4.80	3000	19.71	0.56	0.53	132.59	45.0	164.0
sDB9733V24U	B.S	24	14.0~27.6	1.00	24.00	4500	29.76	0.84	1.35	336.96	57.0	164.0
sDB9733V24H	B.S	24	14.0~27.6	0.80	19.20	4000	26.62	0.75	1.15	286.75	53.0	164.0
sDB9733V24M	B.S	24	14.0~27.6	0.50	12.00	3500	23.34	0.66	0.83	206.33	49.0	164.0
sDB9733V24L	B.S	24	14.0~27.6	0.30	7.20	3000	19.71	0.56	0.53	132.59	45.0	164.0

Specifications are subject to change without notice. Please visit our website at <http://www.sofasco.com> for update information

Dimensions (Unit:mm)

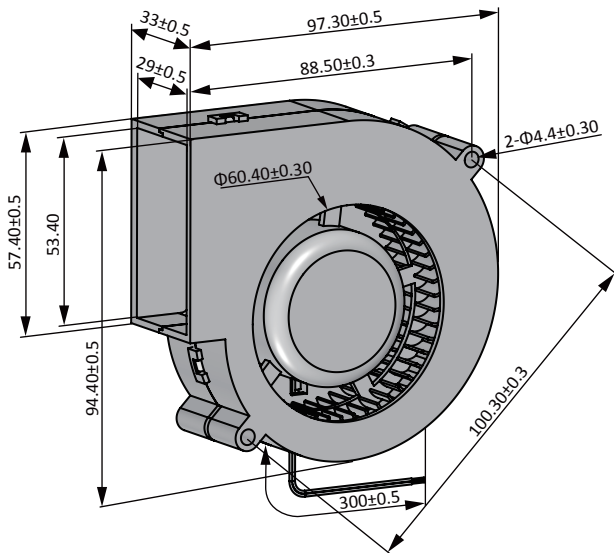

PQ Curve (At rated Voltage)

