

## 9225

## 92x92x25MM



### General Specifications

- ◆ Material..... Frame: Plastic (UL94V-0)  
Impeller: Plastic (UL94V-0)  
Lead Wire: UL1007AWG#24 or Equivalent (+) Red, (-) Black
- ◆ Expected Life..... Ball Bearing 70,000hrs (40°C)  
Sleeve Bearing 30,000hrs (40°C)
- ◆ Temperature Range.... Operating temperature -10°C~70°C (Non-condensing)  
Storage temperature -40°C~70°C (Non-condensing)
- ◆ Safety Standards..... UL, TUV, RoHS, CE
- ◆ DC Fan Specials..... RD, FG, PWM, IP56

### Specifications

Model	#Bearing Type	Rated Voltage	Operating Voltage	Input Current	Input Power	Speed	Max Air Flow		Max Static Pressure		Noise	Weight
Part No.	B.S	VDC	VDC	Amp	Watt	RPM	CFM	m <sup>3</sup> /min	Inch-H <sub>2</sub> O	Pa	dB-A	g
sD9225V12U	B.S	12	7.0~13.8	0.60	7.20	4000	63.73	1.80	0.22	55.80	47.0	78.0
sD9232V12H	B.S	12	7.0~13.8	0.50	6.00	3500	54.98	1.56	0.18	43.74	41.0	78.0
sD9232V12M	B.S	12	7.0~13.8	0.40	4.80	3000	46.23	1.31	0.13	31.68	37.0	78.0
sD9232V12L	B.S	12	7.0~13.8	0.30	3.60	2500	37.93	1.07	0.09	22.95	31.0	78.0
sD9232V12D	B.S	12	7.0~13.8	0.20	2.40	2000	30.96	0.88	0.06	16.18	25.0	78.0
sD9232V24U	B.S	24	14.0~27.6	0.50	12.00	4000	63.73	1.80	0.22	55.80	47.0	78.0
sD9232V24H	B.S	24	14.0~27.6	0.40	9.60	3500	54.98	1.56	0.18	43.74	41.0	78.0
sD9232V24M	B.S	24	14.0~27.6	0.30	7.20	3000	46.23	1.31	0.13	31.68	37.0	78.0
sD9232V24L	B.S	24	14.0~27.6	0.20	4.80	2500	37.93	1.07	0.09	22.95	31.0	78.0
sD9232V24D	B.S	24	14.0~27.6	0.15	3.60	2000	30.96	0.88	0.06	16.18	25.0	78.0
sD9232V48U	B.S	48	28.0~56.0	0.40	19.20	4000	63.73	1.80	0.22	55.80	47.0	78.0
sD9232V48H	B.S	48	28.0~56.0	0.25	12.00	3500	54.98	1.56	0.18	43.74	41.0	78.0
sD9232V48M	B.S	48	28.0~56.0	0.20	9.60	3000	46.23	1.31	0.13	31.68	37.0	78.0
sD9232V48L	B.S	48	28.0~56.0	0.15	7.20	2500	37.93	1.07	0.09	22.95	31.0	78.0

Specifications are subject to change without notice. Please visit our website at <http://www.sofasco.com> for update information

### Dimensions (Unit:mm)

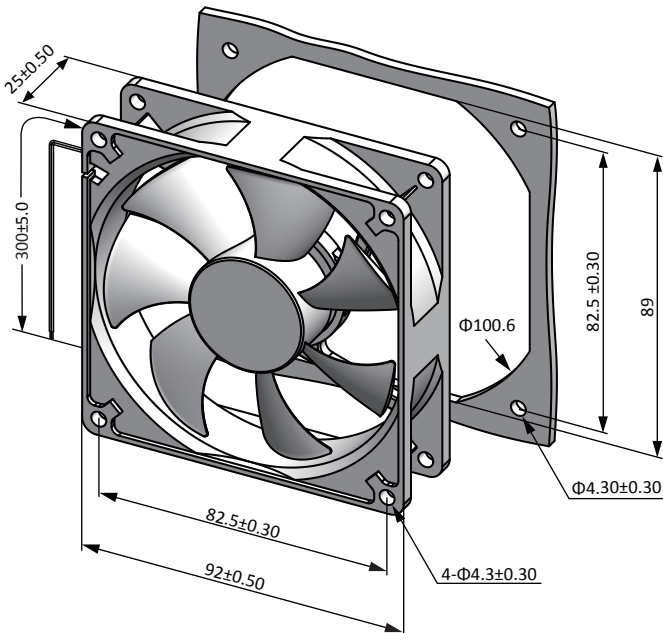

### PQ Curve (At rated Voltage)

