

6010

60x60x10MM



General Specifications

- ◆ Material..... Frame: Plastic (UL94V-0)
Impeller: Plastic (UL94V-0)
Lead Wire: UL1007AWG#26 or Equivalent (+) Red, (-) Black
- ◆ Expected Life..... Ball Bearing 70,000hrs (40°C)
Sleeve Bearing 30,000hrs (40°C)
- ◆ Temperature Range.... Operating temperature -10°C~70°C (Non-condensing)
Storage temperature -40°C~70°C (Non-condensing)
- ◆ Safety Standards..... UJ, TUV, RoHS, CE
- ◆ DC Fan Specials..... RD, FG, IP56

Specifications

Model	#Bearing Type	Rated Voltage	Operating Voltage	Input Current	Input Power	Speed	Max Air Flow		Max Static Pressure		Noise	Weight
Part No.	B.S	VDC	VDC	Amp	Watt	RPM	CFM	m ³ /min	Inch-H ₂ O	Pa	dB-A	g
sD6010V5H	B.S	5	3.5~5.5	0.30	1.50	4000	14.43	0.41	0.16	40.31	32.0	26.0
sD6010V5M	B.S	5	3.5~5.5	0.17	0.85	3000	11.13	0.32	0.10	25.50	25.0	26.0
sD6010V5L	B.S	5	3.5~5.5	0.10	0.50	2000	7.50	0.21	0.06	14.81	22.0	26.0
sD6010V12U	B.S	12	7.0~13.8	0.28	3.36	5000	17.83	0.50	0.23	56.88	35.0	26.0
sD6010V12H	B.S	12	7.0~13.8	0.15	1.80	4000	14.43	0.41	0.16	40.31	32.0	26.0
sD6010V12M	B.S	12	7.0~13.8	0.08	0.96	3000	11.13	0.32	0.10	25.50	25.0	26.0
sD6010V12L	B.S	12	7.0~13.8	0.05	0.60	2000	7.50	0.21	0.06	14.81	22.0	26.0
sD6010V24U	B.S	24	14.0~27.6	0.15	3.60	5000	17.83	0.50	0.23	56.88	35.0	26.0
sD6010V24H	B.S	24	14.0~27.6	0.10	2.40	4000	14.43	0.41	0.16	40.31	32.0	26.0
sD6010V24M	B.S	24	14.0~27.6	0.05	1.20	3000	11.13	0.32	0.10	25.50	25.0	26.0

Specifications are subject to change without notice. Please visit our website at <http://www.sofasco.com> for update information

Dimensions (Unit:mm)

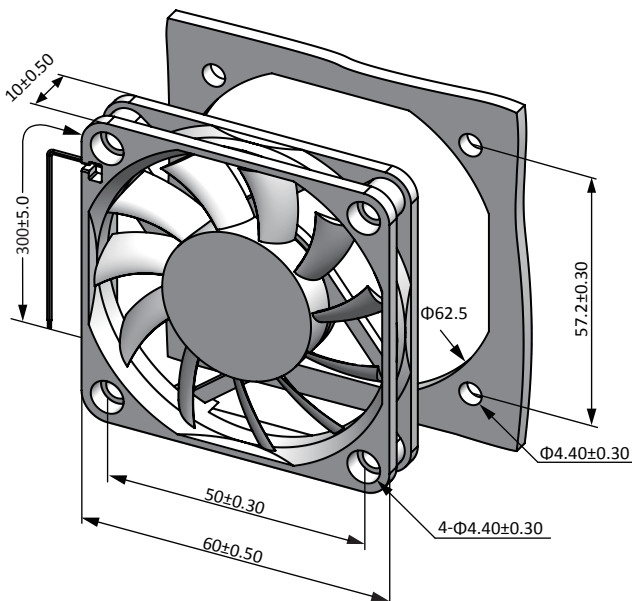

PQ Curve (At rated Voltage)

