

20060 200x200x60MM



General Specifications

- ◆ Material..... Frame: Plastic (UL94V-0)
Impeller: Plastic (UL94V-0)
Lead Wire :UL1007AWG#22 or Equivalent (+) Red, (-) Black
- ◆ Expected Life..... Ball Bearing 70,000hrs (40°C)
- ◆ Temperature Range.... Operating temperature -10°C~70°C (Non-condensing)
Storage temperature -40°C~70°C (Non-condensing)
- ◆ Safety Standards..... UL, TUV, RoHS, CE
- ◆ DC Fan Specials..... RD, FG, PWM, Temperature control, IP56

Specifications

Model	#Bearing Type	Rated Voltage	Operating Voltage	Input Current	Input Power	Speed	Max Air Flow	Max Static Pressure	Noise	Weight		
Part No.	B.S	VDC	VDC	Amp	Watt	RPM	CFM	m ³ /min	Inch-H ₂ O	Pa	dB-A	g
sD20060V12H	B	12	7.0~13.8	3.50	42.00	3000	640.00	18.13	0.97	241.62	68.0	1031.0
sD20060V12M	B	12	7.0~13.8	2.80	33.60	2500	532.00	15.07	0.74	184.33	58.0	1031.0
sD20060V12L	B	12	7.0~13.8	2.00	24.00	2000	490.00	13.88	0.61	151.94	50.0	1031.0
sD20060V24H	B	24	14.0~27.6	2.50	60.00	3000	640.00	18.13	0.97	241.62	68.0	1031.0
sD20060V24M	B	24	14.0~27.6	1.50	36.00	2500	532.00	15.07	0.74	184.33	58.0	1031.0
sD20060V24L	B	24	14.0~27.6	1.00	24.00	2000	490.00	13.88	0.61	151.94	50.0	1031.0
sD20060V48H	B	48	28.0~56.0	1.20	57.60	3000	640.00	18.13	0.97	241.62	68.0	1031.0
sD20060V48M	B	48	28.0~56.0	0.80	38.40	2500	532.00	15.07	0.74	184.33	58.0	1031.0
sD20060V48L	B	48	28.0~56.0	0.50	24.00	2000	490.00	13.88	0.61	151.94	50.0	1031.0

Specifications are subject to change without notice. Please visit our website at <http://www.sofasco.com> for update information

Dimensions (Unit:mm)

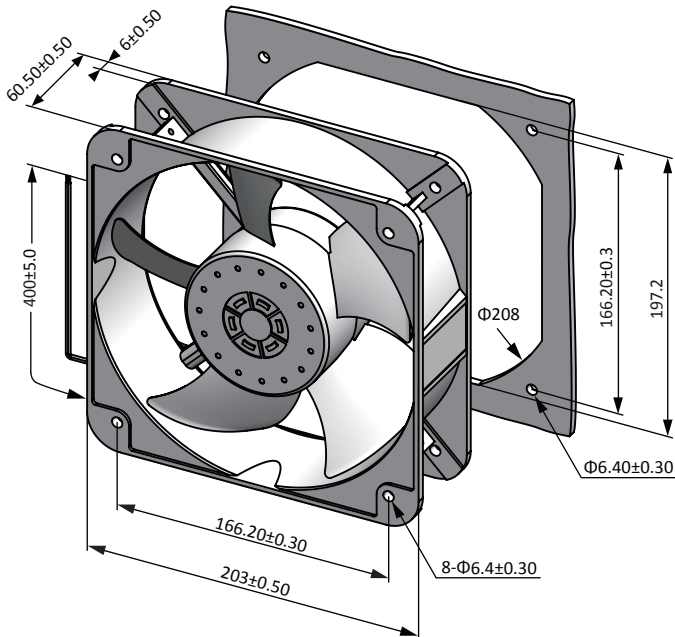

PQ Curve (At rated Voltage)

