



MEV-DC

Continuous Mechanical Extract Ventilation Units

Installation and Maintenance

1.0 Introduction

Nuaire's MEV-DC units are designed to provide continuous mechanical extract ventilation to homes in accordance with Part F of the Building Regulation 2006 & BRE digest 398.

Coding:

Two units are available as standard.
Unit codes/descriptions are as follows:

MEV-DC Single fan unit.

MEV-DC-ES Single fan unit with Ecosmart connector.

The case is constructed in grey /blue ABS plastic. The full length access cover which is located on the underside of the unit, on the opposite side to the mounting bracket, is retained by four ¼ turn fasteners. This cover is acoustically lined with flame retardant acoustic foam (full lining also available).

Figure 1. (shown with optional dampers fitted to spigots).

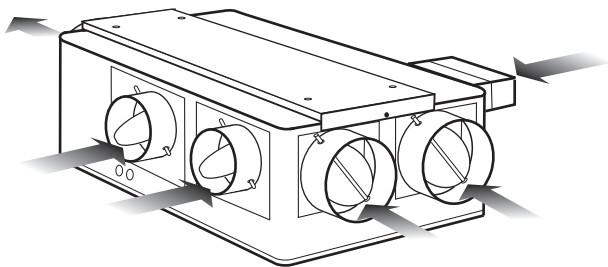

2.0 Installation

Installation must be carried out by competent personnel in accordance with the appropriate authority and conforming to all statutory and governing regulations.

The fan must be fitted indoors, away from sources of water spray or steam generation. The fan can be installed at any angle using the integral mounting bracket supplied (figure 2).

Figure 2.

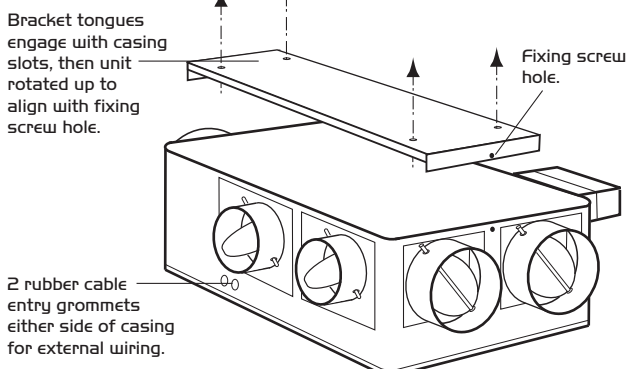

It is assumed that a solid non-reverberant mounting position has been selected and the electrical mains wiring and any optional control wires have been made ready.

It is also assumed that compatible ductwork is already installed and ready to be connected to the 125mm dia. discharge spigot and also the chosen 100mm dia, 125mm dia and/or 110 x 54mm rectangular inlet spigots.

Note the unit is not fitted with a backdraught shutter. (When using the continuous background vent facility a backdraught shutter is not needed). However a backdraught shutter is available from Nuaire if required.

An integral fixing bracket with a single bolt fixing allows easy mounting and removal of the unit when necessary. The unit is supplied with the 125mm dia. discharge spigot for fitting during installation.

2.1 Unit fixing

The integral mounting bracket supplied can be offered up to position, the fixing points marked through and the bracket installed with 4 screws by others. (See figure 2).

Offer the unit into position and locate the bracket into the slots in the case before fixing with the single bracket fixing screw.

Figure 3.

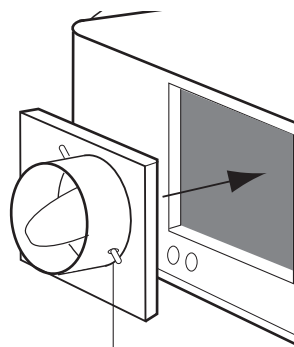

Spigots and spigot blanks are easily removed.

Figure 4.

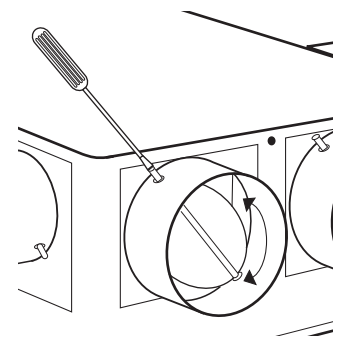

Spigots dampers can be adjusted to the appropriate position using a screwdriver.

Various damper/inlet spigot positions can be utilised as required to suit the system ductwork and extract grilles as all spigot positions are removable. After the spigots has been located in their correct position, adjust the damper with a screwdriver. (See figure 4).

As supplied the unit is fitted with:

5 off blanking plates

4 off 100mm diameter spigots

2 off 125mm diameter spigots

Any, or all of the spigots can be utilised.

110 x 54mm spigots plus additional spigots are available on request.

Volume control dampers and filters (figure 3 and 5.) are optional extras.

If filters are fitted they are located inside the fan case and is easily removed for cleaning following removal of the filter cover.

Please note a clear space of at least 470 x 320mm is required to allow the cover to be removed and provide sufficient access for maintenance.

The fan is designed to be wired direct to the mains supply through a fused spur isolator (by others) and run continuously in the NORMAL mode (which is the low speed, background or trickle ventilation setting) with occasional BOOST airflow (high speed setting) as and when required.

The degree of extract from each room served can be adjusted with the optional inlet balancing dampers or by the use of air-valves.

The unit is provided with adjustment for the low speed (NORMAL) and high speed (BOOST) ventilation rate as required.

2.2 Electrical connection

With the unit fixed in position and working from underneath the installation bring the external wiring through the chosen rubber cable entry grommet (two either side, see figure 2).

The unit **MUST** be Earthed.

IMPORTANT

Isolation - Before commencing work make sure that the unit, and Nuaire control are electrically isolated from the mains supply.

3.0 Dimensions

Figure 5. Dimensions in mm.

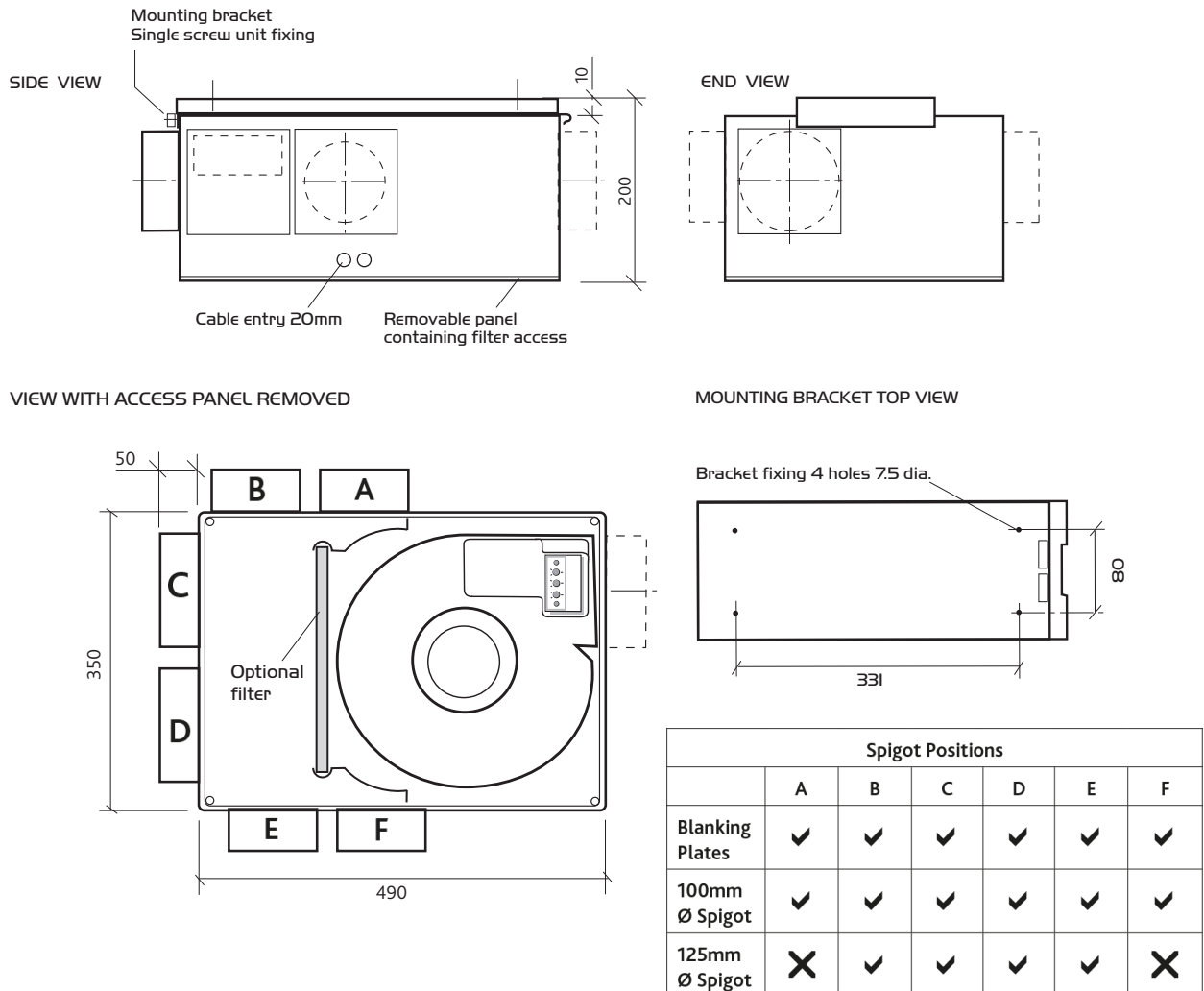

4.0 Electrical Wiring (basic)

Figure 6.

Unit serving Bathroom only

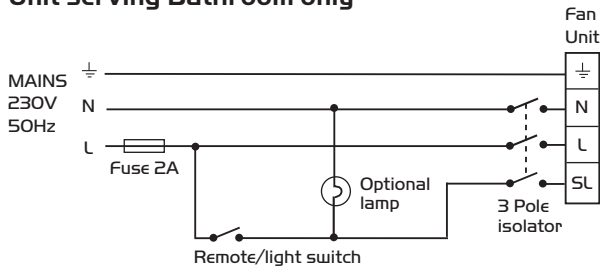

Unit serving Kitchen and two Bathrooms

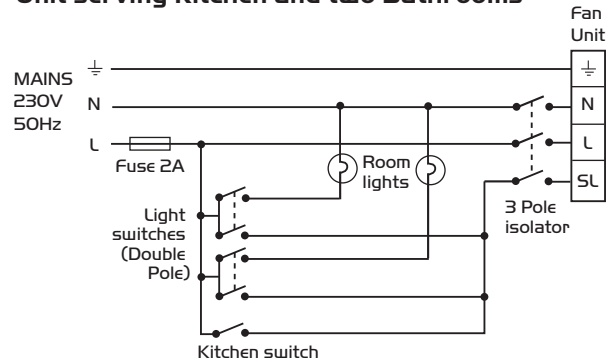

Unit serving Kitchen and Bathroom

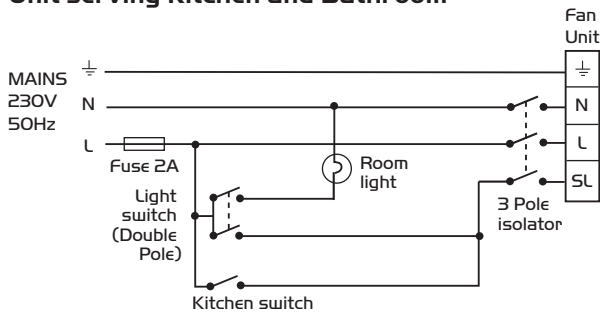

All field wiring, switches and isolators, by others.

4.1 Electrical Wiring (options)

Figure 7. Circuit Board Connections.

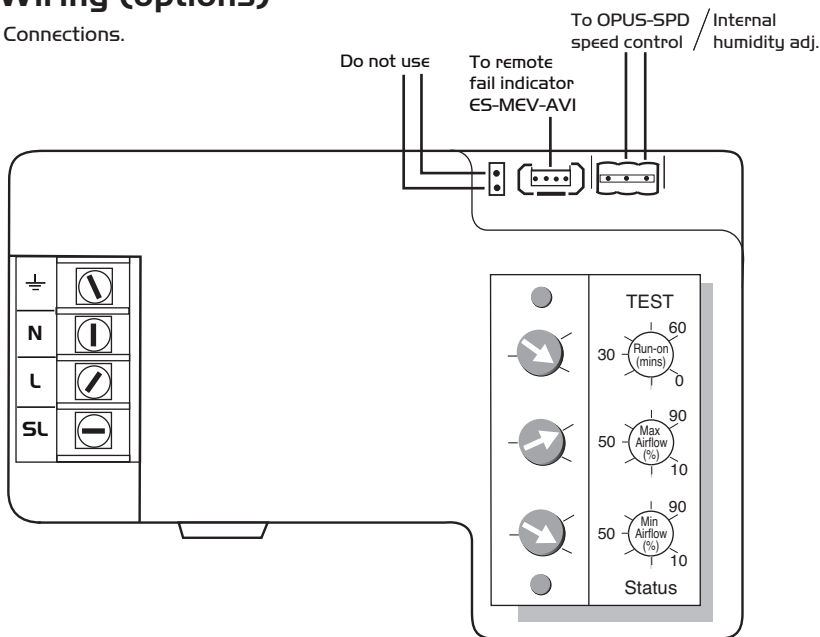

The unit is designed to operate continuously to give a background ventilation rate with the facility to boost the fan to a higher duty as required.

The boost can be achieved by the following methods:

IMPORTANT

For good EMC engineering practice, any sensor cables or switched live cables should not be placed within 50mm of other cables or on the same metal cable tray as other cables.

a) Switched Live (SL)

Connection of 230V mains to SL terminal.

b) Optional Remote Speed Control (OPUS-SPD)

The speed control will mimic the speed between the max and min settings selected at the fan. Connect OPUS-SPD to LV terminal.

c) Internal Humidistat (where fitted)

The internal humidistat can be found on the base of the fan case. The adjustment dial gives a range of 50 - 80% @ 20°C. (See figure 8). Setting to mid position gives 65% which should be acceptable for most circumstances.

If the unit boosts at unacceptable times, this dial should be turned clockwise by a small amount.

Figure 8.

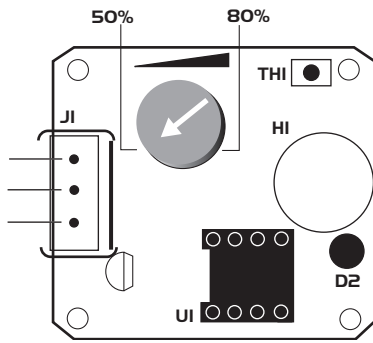

5.0 Volume Control

To control the volume of air the unit is equipped with two control dials, for trickle and boost duties.

In order to set the air extract rates correctly please refer to Approved Document F which can be found at: <http://www.planningportal.gov.uk>

5.1 Run-on Timer

The Run-on timer adjustment is from 0 - 60 mins. **Run-on is only available from the switched live (SL) signal.**

5.2 Status Light

Green light - Fan running.

Red light - Fan failure.

Flashing green light - Set-up period.

Flashing red light - Insufficient pressure reading.

Check ducting/installation e.g. remove inlet/outlet ducting & test.

IMPORTANT

Unit must not be switched off, product is designed to run continuously.

IMPORTANT

Isolation - Before commencing work make sure that the unit, and Nuaire control are electrically isolated from the mains supply.

6.0 Maintenance

It is inevitable that even with filtered extract grilles fitted some dust, fluff etc. will pass through the filter, and which, if allowed, will build up internally on motors and impellers, shortening the life of the unit and, in severe cases, leading to overheating of the motors. Consequently, it is strongly recommended that all units are inspected and cleaned every year. To clean the filter, remove from the unit and wash in tepid water to which a little mild detergent has been added. Shake out excess water and allow to dry naturally. Replace when dry.

7.0 Cleaning

Remove covers and carefully clean out interiors as necessary. Check for damage and security of components. Refit covers.

8.0 Replacement of Parts

Should any component need replacing Nuaire keep extensive stocks for quick delivery. Ensure that the unit is electrically isolated, before carrying out any work.

When ordering spare parts, please quote the serial number of the unit and the ARC number of the purchase if possible. **(This information will be available on the fan label).**

9.0 Warranty

The 5 year warranty starts from the day of delivery and includes parts and labour for the first year. The remaining period covers replacement parts only.

This warranty is void if the equipment is modified without authorisation, is incorrectly applied, misused, disassembled, or not installed, commissioned and maintained in accordance with the details contained in this manual and general good practice.

The product warranty applies to the UK mainland and in accordance with Clause 14 of our Conditions of Sale. Customers purchasing from outside of the UK should contact Nuaire International Sales office for further details.

10.0 After Sales Enquiries

For technical assistance or further product information, including spare parts and replacement components, please contact the After Sales Department.

Telephone 02920 858 400



DECLARATION OF INCORPORATION AND INFORMATION FOR SAFE INSTALLATION, OPERATION AND MAINTENANCE

We declare that the machinery named below is intended to be assembled with other components to constitute a system of machinery. All parts except for moving parts requiring the correct installation of safety guards comply with the essential requirements of the Machinery Directive. The machinery shall not be put into service until the system has been declared to be in conformity with the provisions of the EC Machinery Directive.

Designation of machinery: MEV-DC
 Machinery Types: Continuous Extract Ventilation Unit
 Relevant EC Council Directives: 2006/42/EC (Machinery Directive)
 Applied Harmonised Standards: BS EN ISO 12100-1, BS EN ISO 12100-2, EN60204-1, BS EN ISO 9001, BS EN ISO 13857
 Applied National Standards: BS848 Parts 1, 2.2 and 5

Note: All standards used were current and valid at the date of signature.

Signature of manufacture representatives:

Name:	Position:	Date:
1) C. Biggs 	Technical Director	8. 07. 11
2) A. Jones 	Manufacturing Director	8. 07. 11

INFORMATION FOR SAFE INSTALLATION, OPERATION AND MAINTENANCE OF NUAIRE VENTILATION EQUIPMENT

To comply with EC Council Directives 2006/42/EC Machinery Directive and 2014/30/EU (EMC).

To be read in conjunction with the relevant Product Documentation (see 2.1)

1.0 GENERAL

1.1 The equipment referred to in this Declaration of Incorporation is supplied by Nuaire to be assembled into a ventilation system which may or may not include additional components.
 The entire system must be considered for safety purposes and it is the responsibility of the installer to ensure that all of the equipment is installed in compliance with the manufacturers recommendations and with due regard to current legislation and codes of practice.

2.0 INFORMATION SUPPLIED WITH THE EQUIPMENT

2.1 Each item of equipment is supplied with a set of documentation which provides the information required for the safe installation and maintenance of the equipment. This may be in the form of a Data sheet and/or Installation and Maintenance instruction.
 2.2 Each unit has a rating plate attached to its outer casing. The rating plate provides essential data relating to the equipment such as serial number, unit code and electrical data. Any further data that may be required will be found in the documentation. If any item is unclear or more information is required, contact Nuaire.
 2.3 Where warning labels or notices are attached to the unit the instructions given must be adhered to.

3.0 TRANSPORTATION, HANDLING AND STORAGE

3.1 Care must be taken at all times to prevent damage to the equipment. Note that shock to the unit may result in the balance of the impeller being affected.
 3.2 When handling the equipment, care should be taken with corners and edges and that the weight distribution within the unit is considered. Lifting gear such as slings or ropes must be arranged so as not to bear on the casing.
 3.3 Equipment stored on site prior to installation should be protected from the weather and steps taken to prevent ingress of contaminants.

4.0 OPERATIONAL LIMITS

4.1 It is important that the specified operational limits for the equipment are adhered to e.g. operational air temperature, air borne contaminants and unit orientation.
 4.2 Where installation accessories are supplied with the specified equipment eg. wall mounting brackets. They are to be used to support the equipment only. Other system components must have separate provision for support.
 4.3 Flanges and connection spigots are provided for the purpose of joining to duct work systems. They must not be used to support the ductwork.

5.0 INSTALLATION REQUIREMENTS

In addition to the particular requirements given for the individual product, the following general requirements should be noted.

5.1 Where access to any part of equipment which moves, or can become electrically live are not prevented by the equipment panels or by fixed installation detail (eg ducting), then guarding to the appropriate standard must be fitted.
 5.2 The electrical installation of the equipment must comply with the requirements of the relevant local electrical safety regulations.
 5.3 For EMC all control and sensor cables should not be placed within 50mm or on the same metal cable tray as 230V switched live, lighting or power cables and any cables not intended for use with this product.

6.0 COMMISSIONING REQUIREMENTS

6.1 General pre-commissioning checks relevant to safe operation consist of the following:
 Ensure that no foreign bodies are present within the fan or casing.
 Check electrical safety. e.g. Insulation and earthing.
 Check guarding of system.
 Check operation of Isolators/Controls.
 Check fastenings for security.
 6.2 Other commissioning requirements are given in the relevant product documentation.

7.0 OPERATIONAL REQUIREMENTS

7.1 Equipment access panels must be in place at all times during operation of the unit, and must be secured with the original fastenings.
 7.2 If failure of the equipment occurs or is suspected then it should be taken out of service until a competent person can effect repair or examination. (Note that certain ranges of equipment are designed to detect and compensate for fan failure).

8.0 MAINTENANCE REQUIREMENTS

8.1 Specific maintenance requirements are given in the relevant product documentation.
 8.2 It is important that the correct tools are used for the various tasks required.
 8.3 If the access panels are to be removed for any reason the electrical supply to the unit must be isolated.
 8.4 A minimum period of two minutes should be allowed after electrical disconnection before access panels are removed. This will allow the impeller to come to rest.
NB: Care should still be taken however since airflow generated at some other point in the system can cause the impeller to "windmill" even when power is not present.
 8.5 Care should be taken when removing and storing access panels in windy conditions.