

Unity CV2.1

Installation and Operating Instructions

The Unity CV2.1 is a continuously running extract fan, designed to offer a simplistic approach to meet Building Regulations and provide an energy efficient domestic ventilation solution to improve indoor air quality in dwellings.



Please read instructions before commencing the installation.

Please make these instructions available for the user.



The Unity CV2.1 is a continuously running fan that revolves around 'one product', which has been designed to be flexible in application and to meet the performance requirements of all 'wet' rooms within a dwelling.

This product features on the PCDB, part of the process will require the Installation and Commissioning Checklist for dMEV products to be completed, see page 7 for details.

The Unity CV2.1 features Greenwood TimerSMART™ and Greenwood HumidiSMART™ technology (fully automatic integral delay / overrun timer and humidity functions) which monitor the homeowners' environment.

The boost speed facility is provided to increase the ventilation rate during peak times, helping to provide a comfortable indoor environment. Either a 'switch-live' light switch or an alternative boost switch (not supplied) should be wired to provide this operation.

Note: These functions only affect the higher extract boost mode, your fan will continue to ventilate at the lower trickle mode.

Key: Installer Information **pages 2 - 8**

User Information **pages 9 - 11**

Important:

Please read these instructions before commencing the installation

- This appliance can be used by children aged from 8 years and above and persons with reduced physical, sensory or mental capabilities or lack of experience and knowledge if they have been given supervision or instruction concerning use of the appliance in a safe way and understand the hazards involved. Children shall not play with the appliance.
- Cleaning and user maintenance shall not be made by children without supervision. Ensure the fan is switched off from the mains supply before cleaning commences.
- Where an open-flued oil or gas-fuelled appliance is installed, precautions must be taken to avoid a back-flow of gases into the room.
- When installing wall mounted fans, ensure that there are no buried cables or pipes in the way. It is recommended that this fan is mounted >1.8m above floor level and within 400mm of the finished ceiling.
- The fan should not be sited where it would be subject to a direct heat source in excess of 40°C.
- Observe appropriate safety precautions if working on steps or ladders.
- Wear eye protection when breaking out wall or ceiling materials, etc.
- To disassemble the unit, disconnect from mains supply and use a screwdriver to segregate the electronic components and motor from the plastic housing. Dispose items in accordance with WEEE.

WEEE Statement

This product may not be treated as household waste. Instead it should be handed to an appropriate collection point for the recycling of electrical and electronic equipment. For more detailed information about the recycling of this product, please contact your local council office or your household waste disposal service.



Installation Preparation

Electrical installation must only be carried out by a qualified Electrician and in accordance with local regulations.

The Unity CV2.1 fan is supplied with a 100mm nominal spigot for connection of ducts for installation - 100mm diameter rigid or 110mm semi-rigid ducting should be used to provide the best performance levels required for compliance with Building Regulations.

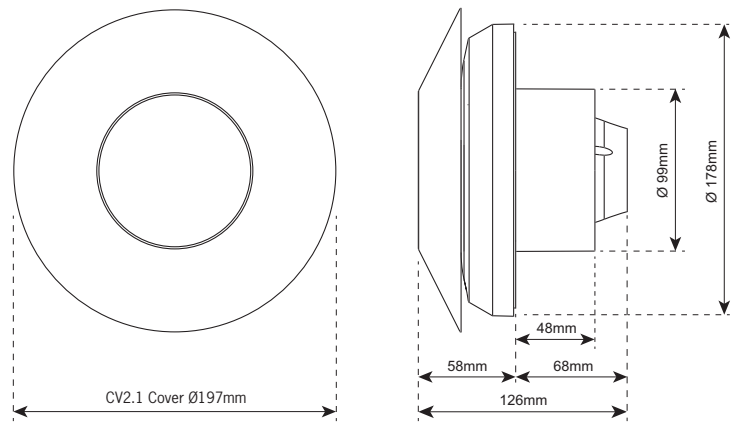

Preparing your fan for installation

Upon removal from packaging, rotate 'outer cover' anticlockwise until retaining clips are released and place the cover to one side.

Loosen retaining screw in main body cover and rotate anticlockwise to remove.

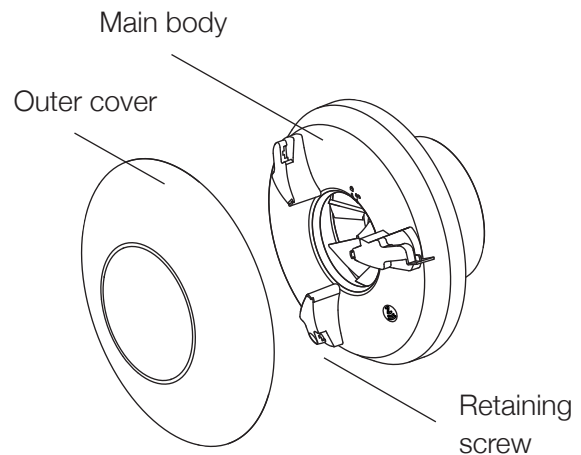

The unit can be installed on a wall, window (with separate adaptor kit) or ceiling mounted and ducted.

Wall Preparation

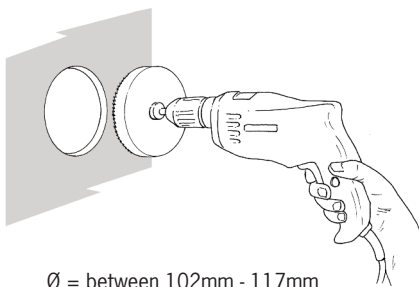

\varnothing = between 102mm - 117mm
(to suit ducting dimensions)
Allow a clearance of 50mm from wall/ceiling edges around the fan.

Cut the duct to depth of the plasterboard or tiled wall with slight fall to exterior (Make provisions for cable).

Fill in any gaps with mortar or foam and make good internal and external walls. Make sure that ducting retains its original shape.

Ceiling Preparation

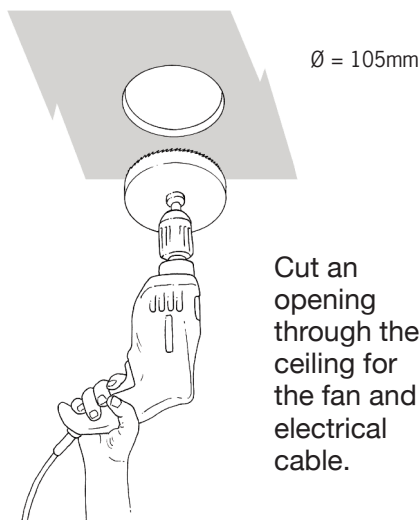

$\varnothing = 105\text{mm}$
Cut an opening through the ceiling for the fan and electrical cable.

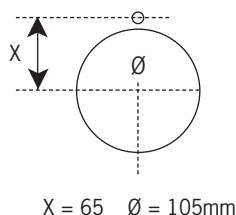

Window Preparation

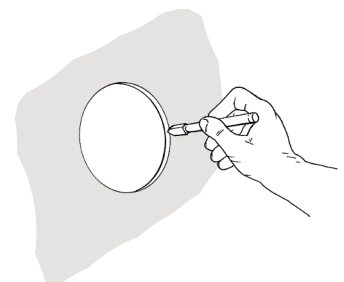

Cut circular hole within window pane.

- minimum $\varnothing = 118\text{mm}$
- maximum $\varnothing = 130\text{mm}$

See instructions with window kit for installation details.

Installation

STEP 1

Connect ducting to the spigot on the back of the Unity CV2.1

Note: If using flexible ducting, ensure this is pulled taut (to a min. 90% stretch capacity) between fan and termination

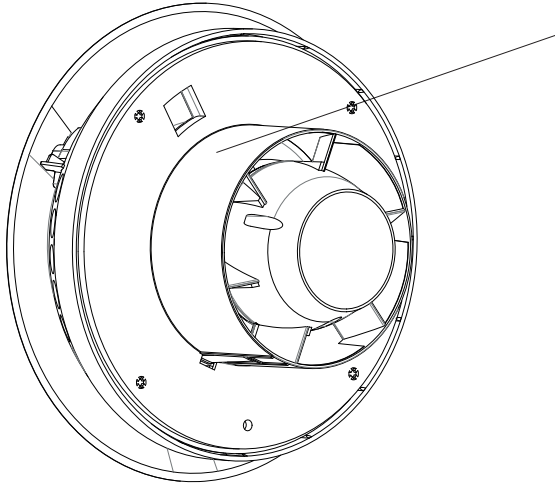

STEP 2

Loosen retaining screw until you can rotate main body cover of the fan anticlockwise to 'unlock position' and remove cover

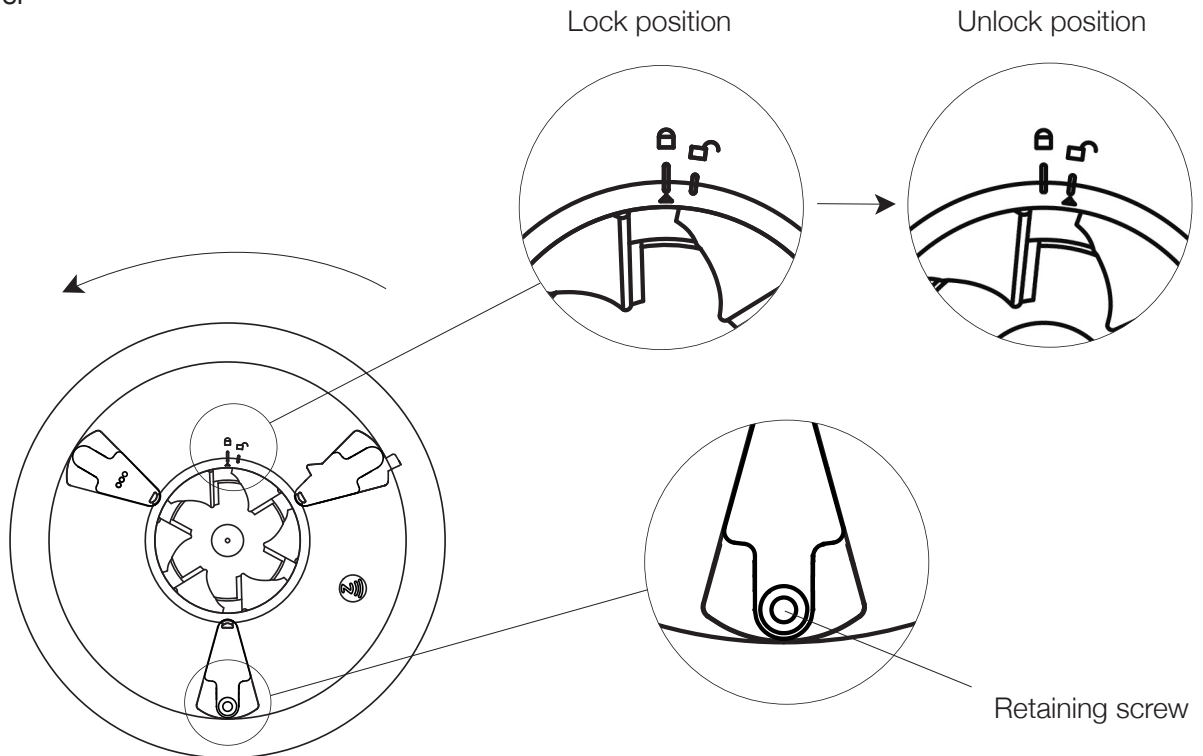

STEP 3

Wire the fan

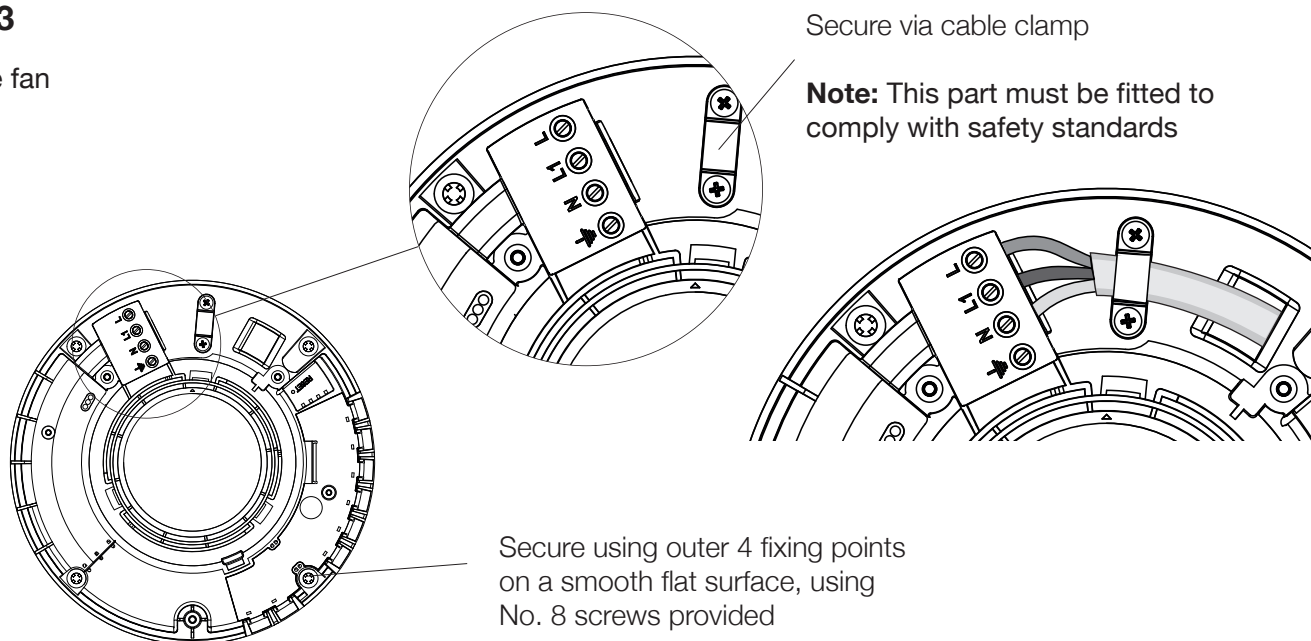

Electrical Installation Preparation

Installation or disconnection must be carried out by a qualified Electrician and all wiring must conform to local regulations. Isolate electricity supply before starting work.

A triple-pole switch having a minimum contact separation of 3mm must be used to provide isolation for the unit. When supplied from a 6 amp lighting circuit no local fuse is required. If electricity is not supplied via the lighting circuit, a localised 3 amp fuse must be used.

Unity 230V Wiring Details

☐ IPX5 Wall, IPX4 Ceiling, 220-240V ~ 50Hz / 1Ph, 7 Watts max.

Cable size: Fixed flat wiring 2 core 1mm², 3 core 1/1.5mm²

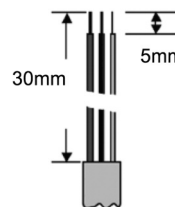
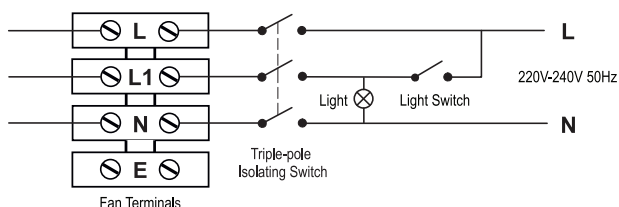

Strip cable to correct lengths and insert cable through cable entry point at the back of the fan.

Tighten cable clamp and push wires into the terminal block as per wiring diagram, tighten screws of the terminal block.

Note: A facility to park the earth cable has been provided; as the fan is double insulated no connection to earth is required.

STEP 4

Turn power off and locate main body cover via the arrow & unlock position, rotate clockwise to 'lock position'

Tighten retaining screw until main body cover cannot be opened.
Turn power on and follow respective commissioning on page 8

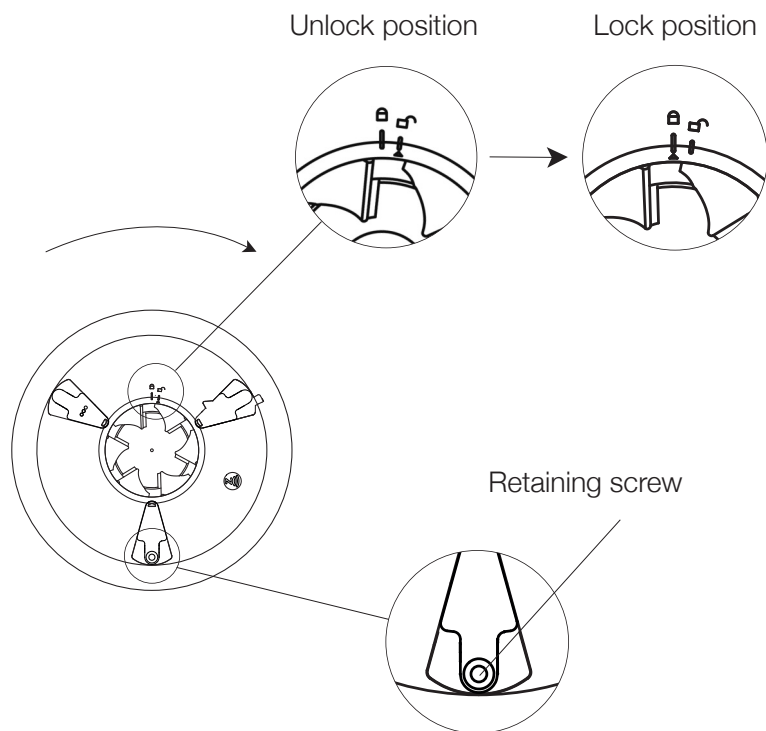

STEP 5

Reattach the front cover by rotating clockwise, utilising the guidance rail, until firmly secured by the retaining clips

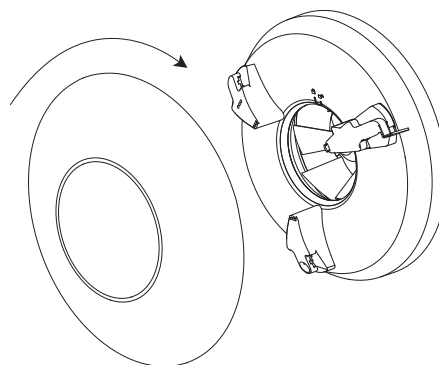

A 100mm nominal diameter spigot is provided for connection to ducting. Ductwork should be securely connected to the back of the fan. Failure to do this will cause unnecessary air leakage and may impair performance.

Commissioning your Unity CV2.1

Upon first power up, your Unity CV2.1 will commence a diagnostic check, whereby the capacitive touch buttons will flash. You should hear a range of beeps, 1 long beep followed by 3 short beeps. Following diagnostic completion, the 'Kitchen and Bathroom' buttons will start to flash, follow the steps for commissioning airflow.

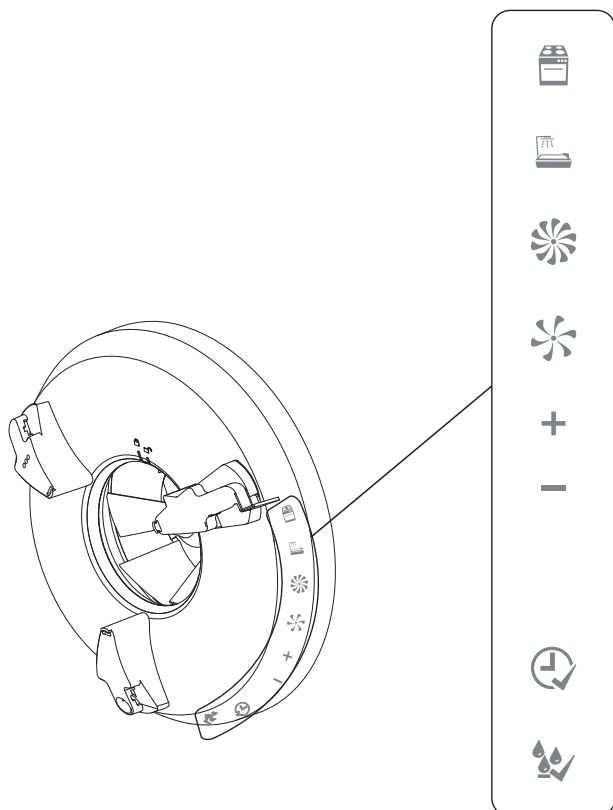

Step 1

Press Bathroom or Kitchen button
- light will go solid

Step 2

Boost Airflow button will flash
- factory setting:

	Bathroom 8 l/s	Kitchen 13 l/s
--	----------------	----------------

Press speed adjustment buttons to required level and verify
- re-press Boost button to confirm

Step 3

Trickle Airflow button will flash
- factory setting:

	Bathroom 6 l/s	Kitchen 8 l/s
---	----------------	---------------

Press speed adjustment buttons to required level and verify
- re-press Trickle button to confirm

Step 4

For HumidiSMART press button to turn on
- light will go solid



Step 5

For TimerSMART press button to turn on
- light will go solid



Note: Selection lights should remain on for approximately 10 seconds to enable the setup and status of the fan to be observed and checked, upon which time the selected commissioning settings should lock out.

Installation Checklist & Inspection Record

This product features on the PCDB, part of the process will require the Installation and Commissioning Checklist for dMEV products to be completed and submitted to building control and incorporated into the homeowner pack.

This documentation is available at <https://www.greenwood.co.uk/part-f> or via the QR codes in this section.



Scan for
Installation Checklist



Scan for
Inspection Record

Performance Graph - airflow characteristics

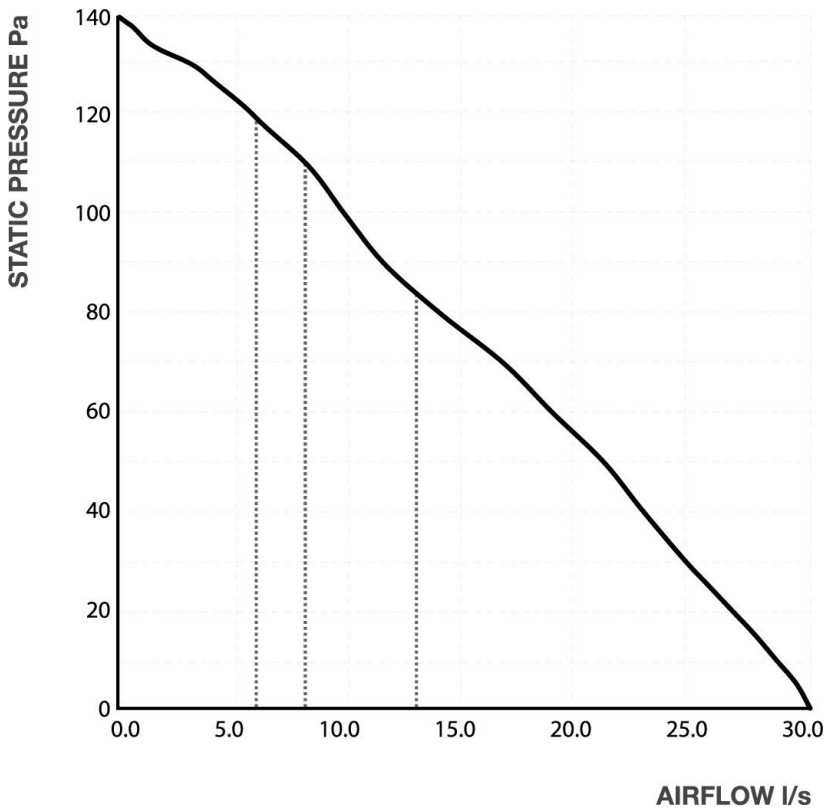

Airflow Settings l/s	Bathroom (Default)	Kitchen (Default)
Trickle	6	8
Boost	8	13

Key

— Unity CV2.1
100% variable setting

..... For manual airflow
volume setting

To master reset and recommission your Unity CV2.1

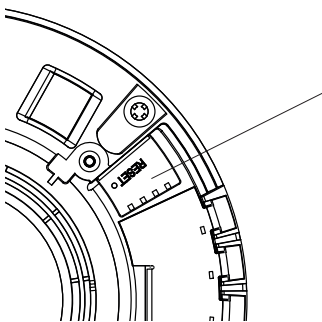

Resetting your Unity CV2.1 must be carried out by a qualified electrician or competent person.

Whilst the fan is running, remove both the outer cover and main body cover of the fan (see installation section page 4).

Locate the 'reset' button and depress using a small 'pin-sized' tool for 3 seconds. All lights will turn on to show the unit has been reset.

Turn the power OFF to the fan → refit the main body cover.

Locate main body cover via the arrow & unlock position, rotate clockwise to 'lock position'.

Tighten retaining screw until main body cover cannot be opened.

Turn the power to the fan ON → recommission (see page 7).

Note: Your fan will remember its previous timer and humidity settings, if required, these can be changed during the recommissioning section.

SMART Technology

To maintain a healthy indoor environment the Unity CV2.1 includes SMART technology for Over-run Timer (Greenwood TimerSMART™) and Humidity (Greenwood HumidiSMART™).

Greenwood TimerSMART™ monitors the length of time that there is an occupancy presence within a wet room (via the 'switch-live') and provides a fixed over-run time period to best match the length of time that the 'switch live' is active (as shown below):

Time 'Switch Live' is Active	Over-run Boost Period
0 – 5 minutes	No over-run
5 – 10 minutes	5 minutes
10 – 15 minutes	10 minutes
15+ minutes	15 minutes

Note: the first 5 minutes will not activate an over-run.

Greenwood HumidiSMART™ monitors the ambient humidity within the wet room environment and looks for short peaks of humidity made by either showering or bathing. This smart technology ensures that your Unity CV2.1 is not on boost for prolonged periods of time, removing nuisance running noise and unnecessary energy wastage typically associated with increases to background humidity which naturally occurs with the changing seasons.

To View Fan Set Up / Status

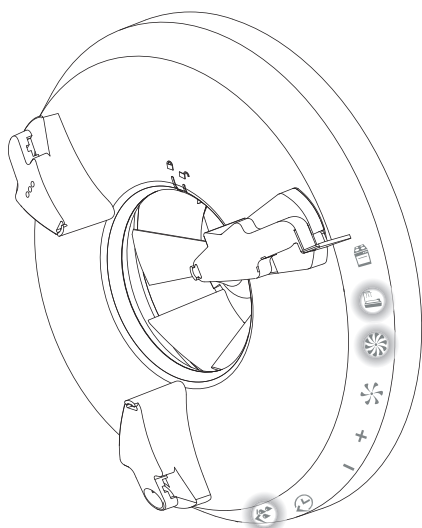

Press any button to activate the panel. The current fan set up / status will be shown via the red LED lights.

Example shows:

- Bathroom setting selected
- Boost mode activated
- HumidiSMART feature selected

Note: The Unity CV2.1 is commissioned during installation to provide the correct airflow requirements for your dwelling. Post adjustment of the room setting or airflow speeds is not available.

To Change the TimerSMART / HumidiSMART Settings

To identify current fan status, press any button to activate the panel. Upon identification of controls status, either press:



to activate or deactivate the TimerSMART



to activate or deactivate the HumidiSMART

Please note the light should come on to indicate that the function is active.

Note: After approximately 10 seconds of inactivity, the LED lights should turn off and save selection settings.

Note: Both features are factory set to 'off', both can be activated at the same time.

Servicing / Maintenance

Service / Maintenance must be carried out by a trained / competent person.

The Unity CV2.1 fan contains a unique backward curved mixed flow impellor that has been designed to reduce build-up of dirt. The fan motor has sealed for life bearings, which do not require lubrication.

Periodic cleaning of the fans front cover and casing can be carried out using a soft damp cloth.



Always isolate fan from mains supply before cleaning.

Do not use solvents to clean this fan.

Cleaning and user maintenance shall not be made by children without supervision.

Please note that your stored fan settings will not be lost during any interruptions to your fan's power supply.

Troubleshooting

Question	Answer
<p>I don't think that my fan is working</p>	<p>The fan is very quiet when the room's light is off, but it is still extracting and working to provide you with enhanced comfort</p> <p>If in doubt, remove the front cover to expose the fan. If the fan impellor is not rotating then contact your local installer.</p>
<p>My fan is running all the time</p>	<p>This is correct; it will run at a low speed whilst your room is unoccupied to provide continuous ventilation</p>
<p>My fan is running faster and noisier</p>	<p>Your fan will automatically go into "boost" mode when you turn the light on or if the HumidiSMART is activated, when you have a bath / shower / generate steam via cooking</p> <p>The fan will run at a faster speed which generates more noise as more air is being extracted</p>
<p>My fan still runs faster and noisier when I turn the light off</p>	<p>Has the bathroom light been left on for more than 5 minutes?</p> <p>If yes, your fan has the TimerSMART activated and the fan will run at the higher noisier "boost" rate between 5 - 15 minutes and it will then return to the lower quieter continuous speed setting</p>
<p>Why can't I turn the fan off</p>	<p>Your fan has been designed to ventilate the room continuously (i.e. 24/7) to improve the indoor air quality and enhance your comfort</p>
<p>How do I change my fan's settings</p>	<p>To identify current fan status, press any button on the fan to activate the LED lights. Upon identification of control status, press the required icon to change the settings (note, the light should come on to indicate that the function is active):</p> <p> Touch TimerSMART button for on or off</p> <p> Touch HumidiSMART button for on or off</p> <p>After approximately 10 seconds of inactivity the LED light should turn off and save selection settings.</p> <p>Note: Both features can be activated at the same time.</p>

All information is believed correct at time of going to press. All dimensions referred to are in millimetres unless otherwise shown. E&OE.

All goods are sold according to Zehnder Group International Sales Standard Conditions of Sale which are available on request. See website for warranty period details.

Zehnder Group International Sales reserves the right to change specifications and prices without prior notice.
© Copyright Zehnder Group UK Ltd 2022.

Zehnder Group UK Limited

Watchmoor Point, Camberley,
Surrey, GU15 3AD

Customer Services: +44 (0) 1276 408404

Technical Services: +44 (0) 1276 408402

Email: info@greenwood.co.uk

Web: www.greenwood.co.uk

40025869 – June 2022