

HRV 1.3 Q Plus
HRV 1.35 Q Plus

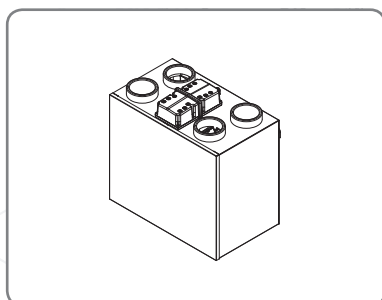

HRV 1.60 Q Plus
HRV 1.65 Q Plus

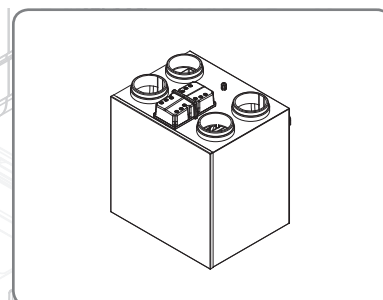

HRV4 Q Plus
HRV4.1 Q Plus
HRV4.25 Q Plus

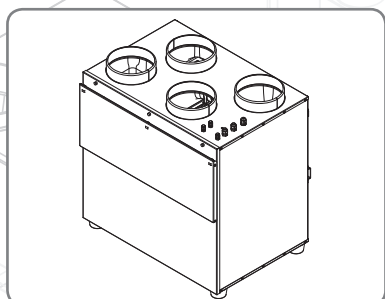

HRV20 Q Plus

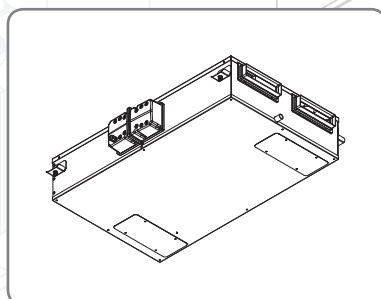

H200 Q Plus

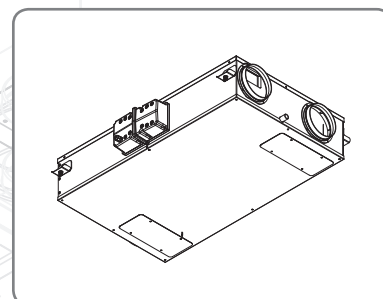

H200 Q Plus



Warnings, Safety Information and Guidance







Important Information

Important: read these instructions fully before the installation of this appliance

1. Installation of the appliance and accessories must be carried out by a qualified and suitable competent person and be carried out in clean, dry conditions where dust and humidity are at minimal levels.
2. This manual covers the installation of the Heat Recovery Ventilation (HRV) unit
3. All wiring must conform to current I.E.E. Wiring Regulations and all applicable standards and Building Regulations.
4. Inspect the appliance and electrical supply cord. If the supply cord is damaged, it must be replaced by the manufacturer, their service agent or similarly qualified persons in order to avoid a hazard.
5. The unit is supplied with a mains rated 3 core flexible cord (PVC sheathed, brown, blue and green/yellow 0.75mm²).
6. The appliance must be connected to a local double pole isolation switch with a contact separation of at least 3mm.
7. The appliance must be earthed.
8. HRV1.3, HRV1.35, HRV1.6, HRV1.65, HRV4, H200 Q Plus units suitable for 230V ~ 50/60Hz single phase with a fuse rating of 3A.
9. HRV20Q Plus suitable for 230V ~ 50/60Hz single phase with a fuse rating of 5A.
10. Control, Boost & communication cable access is via the fitted cable gland(s) which are suitable for Ø3- 6mm cable.
11. Control, Boost & communication cables - Unshielded 4 Core minimum 18-24AWG Stranded, Tinned Copper. Control Cables must not be twisted pairs.
12. All Control, Boost & Communication cables should not be placed within 50mm or on the same metal cable tray as any 230V~ lighting or power cables.
13. Ensure all cable glands are fully tightened.
14. The unit must be stored in a clean and dry environment. Do not install the appliance in areas where the following may be present or occur;
Excessive oil or a grease laden atmosphere,
Corrosive or flammable gases, liquids or vapours,
Ambient temperatures above 40°C or below -5°C,
Humidity levels above 90% or is a wet environment.
15. The appliance is not suitable for installation to the exterior of the dwelling.

-
16. This appliance can be used by children aged from 8 years and above and persons with reduced physical, sensory or mental capabilities or lack of experience and knowledge if they have been given supervision or instruction concerning use of the appliance in a safe way and understand the hazards involved. Children should be supervised to ensure that they do not play with the appliance. Cleaning and user maintenance shall not be made by children without supervision.
 17. Ensure that external grilles are located away from any flue outlet, in accordance with relevant Building Regulations.
 18. The unit must not be connected to a tumble dryer or a cooker hood.
 19. Heat recovery systems and extract fans can create negative pressures within rooms. Ensure precautions are taken to avoid negative pressure creating a back-flow of gases into the room from an open flue.
 20. Ensure all ducting, condensate drain and associated pipe work is free from debris and blockages before switching on the unit

Explanation of symbols on the appliance

Symbol	Definition
	Read instruction Manual.
	Risk of Electric Shock.
	General hazard safety alert.
	Wait until all machine components have completely stopped before touching them.
	Disconnect the mains supply before removing this cover.
	Disconnect the mains supply before removing this cover. Before obtaining access to terminals or removing this cover, all supply circuits must be disconnected.

Titon Recommend:

- Any flexible ducting should only be used for final terminations only and must be a maximum of 300m long and be pulled taut, and straight.
- A minimum distance of 200mm between the HRV unit and any sharp bends in duct work.
- Ducting should be insulated where it passes through unheated areas and voids with the equivalent of at least 25mm of a material having a thermal conductivity of $\leq 0.04 \text{ W/(m.K)}$ to reduce the possibility of condensation forming. Where a duct extends externally above roof level the section above the roof should be insulated or a condensate trap should be fitted just below roof level.
- Ducts within the building heated envelope between the external terminals and the unit's From Atmosphere and To Atmosphere ports should be insulated and wrapped additionally with a vapour barrier outside the insulation.
- Where duct pass through any fire barriers or walls, they must comply with the requirements of local Building Regulations.
- A ducting condensate drain must be fitted to vertical To Atmosphere duct work.
- Ducting must be installed in such a way that resistance to airflow is minimised.
- Ducting connected to the From Atmosphere & To Atmosphere ports, must be to/from the external air outside the building envelope.
- Duct joints to the unit's duct ports must be fixed using a method that ensures a long term seal is achieved. If using a short piece of flexible ducting secure using a hose clamp, do not over tighten hose clamp; as overtightening may distort and reduce the unit's port.
- A minimum distance of 2m exists between the external supply and exhaust terminals.

Contents

Warnings, Safety Information and Guidance		Wiring	
Important Information	2	Wiring Access	22
Explanation of symbols on the appliance.	4	HRV20	22
Titan Recommend:	5	Supply	22
Units		auralite®	23
List of Products	7	Switching & Controls	24
Product Information		Commissioning	
Packaging Contents	8	Controls	26
Units' Dimensions		Control Parameters	26
HRV1.3 & 1.35 <i>Q Plus</i>	9	Continuous Supply & Extract Speeds:	26
HRV1.6 & 1.65 <i>Q Plus</i>	9	Boost Supply & Extract Speeds:	27
HRV4, 4.1 & 4.25 <i>Q Plus</i>	10	Boost Overrun	27
HRV20 <i>Q Plus</i>	10	Humidity Sensor.	27
H200 <i>Q Plus</i> (Horizontal Unit).	11	Controller Reset	27
Product Features		Hardware Reset	27
Filter Covers.	12	Maintenance	
auralite®	12	Routine Maintenance	28
Auto Setback Speed.	12	Cleaning Exterior	28
Continuous Speed	12	Cleaning Interior	28
Boost Speed with Overrun Timer	12	HRV1.3, 1.35, 1.6, 1.65, 4, 4.1 & 4.25.	28
auralite® Boost Alert.	12	Front Cover Removal	28
Summer Bypass	13	Condensate Tray	28
SUMMERboost®	13	HRV20	29
Automatic Frost Protection	13	Front Cover Removal	29
Integrated Humidity Sensor	13	H200	29
Enthalpy humidity-recovery	13	Access to Interior for cleaning.	29
Installation		Filter Replacement	30
Unit Mounting	14	HRV 1.25, 1.3, 1.35, 1.6, 1.65, 4, 4.1 & 4.25.	30
All Units except H200.	14	HRV20	31
Safety Bracket	15	H200	32
HRV20	15	Service Record	34
Other Units	15		
Mounting H200.	16		
Condensate Drain	17		
HRV1.3 & 1.35	18		
HRV 1.6 1.65, 4, 4.1 & 4.25	18		
Blanking Plug	18		
HRV20	19		
Horizontal Unit(s)			
H200.	20		
Ducting Connections			
Port Designations.	21		

Units

List of Products

This Manual is for the following Products

HRV1.3	TP473HMB	H200 204x60	TP451HMB
HRV1.35	TP408HMB	H200 Ø150	TP452HMB
HRV1.6	TP409HMB	H200 Ø160	TP453HMB
HRV1.6	TP410HMB		
HRV1.65 HE	TP448HMB		
HRV20 HE	TP652HMB		
HRV4	TP421HMB		
HRV4.1	TP422HMB		
HRV4.25	TP423HMB		

all with either suffix /544 or /RH



When this document is viewed as a PDF the headings & sub headings on this page are hyper links to the content. Additionally the page numbers in this document are hyper links back to this contents page.

Product Information

The HRVs are Mechanical Ventilation with Heat Recovery (MVHR) units. They are designed for the energy efficient ventilation of dwellings. The units are designed for continuous ventilation, exhausting stale moist air from bathrooms, toilets, kitchen and utility rooms.

As the stale air is extracted, the unit's heat exchanger transfers heat, which would have been wasted, to the fresh air being supplied to the bedrooms and living rooms.

Packaging Contents

Inspect the unit when taking delivery. Each unit is supplied with various accessories. Check the unit for damage and that all unit specific accessories have been supplied.

Unit	Mounting Bracket	Safety Bracket(s) Kit	Condensate Drain Olive & Nut	Condensate Drain Blanking Plate	M6x10 Pan HD screw	M6 washer	Transport Bungs	Product Manual	EuP Documentation	40x12 Hose Clamp	Port Cover / 150-125mm adapters	Condensate bung	M5x10 Pan HD screw	M5 Star washer
HRV1.3 & 1.35	2	1	1	1	4	4	4	1	Yes					
HRV1.6 & 1.65														
HRV4, 4.1 & 4.25														
H200	4											8	8	
HRV20	2	1								1	2	1		

Units' Dimensions

The following diagrams detail the overall size of the units, the duct port positions & the additional space required around the units (Service Void - - - -) to allow for commissioning and future service and maintenance.

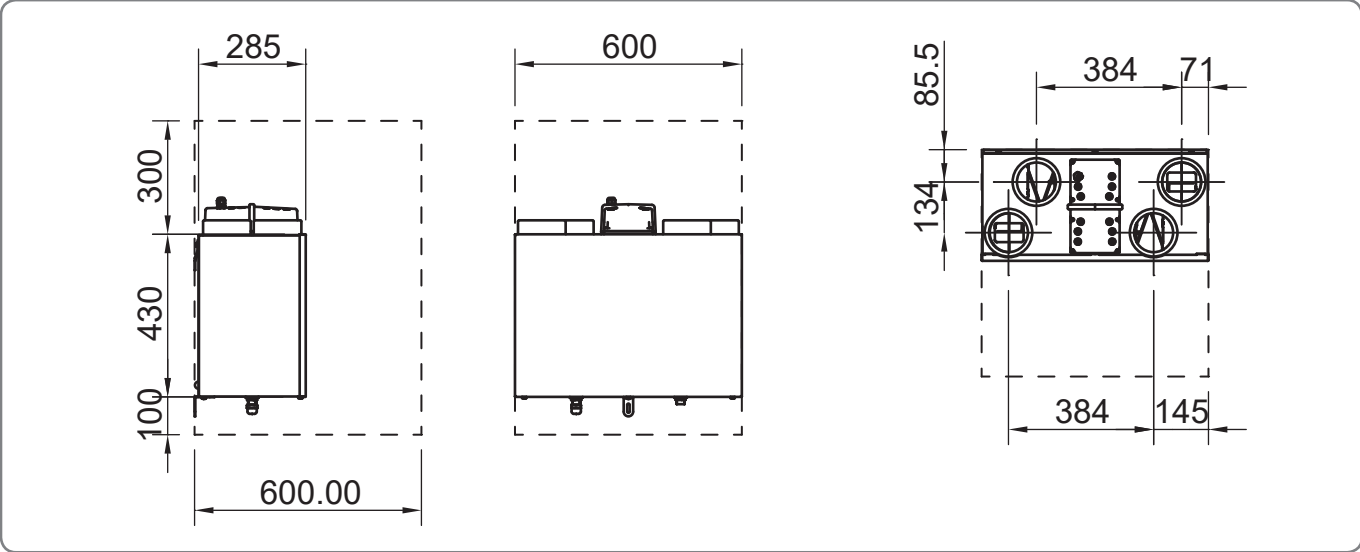

HRV1.3 & 1.35 Q Plus

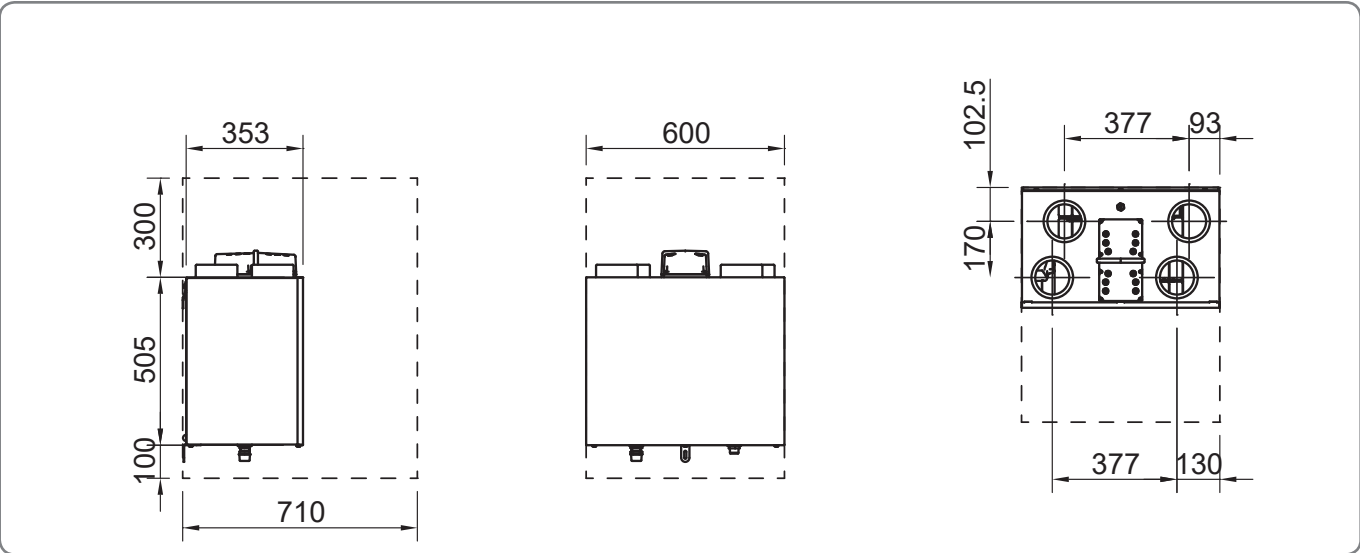

HRV1.6 & 1.65 Q Plus

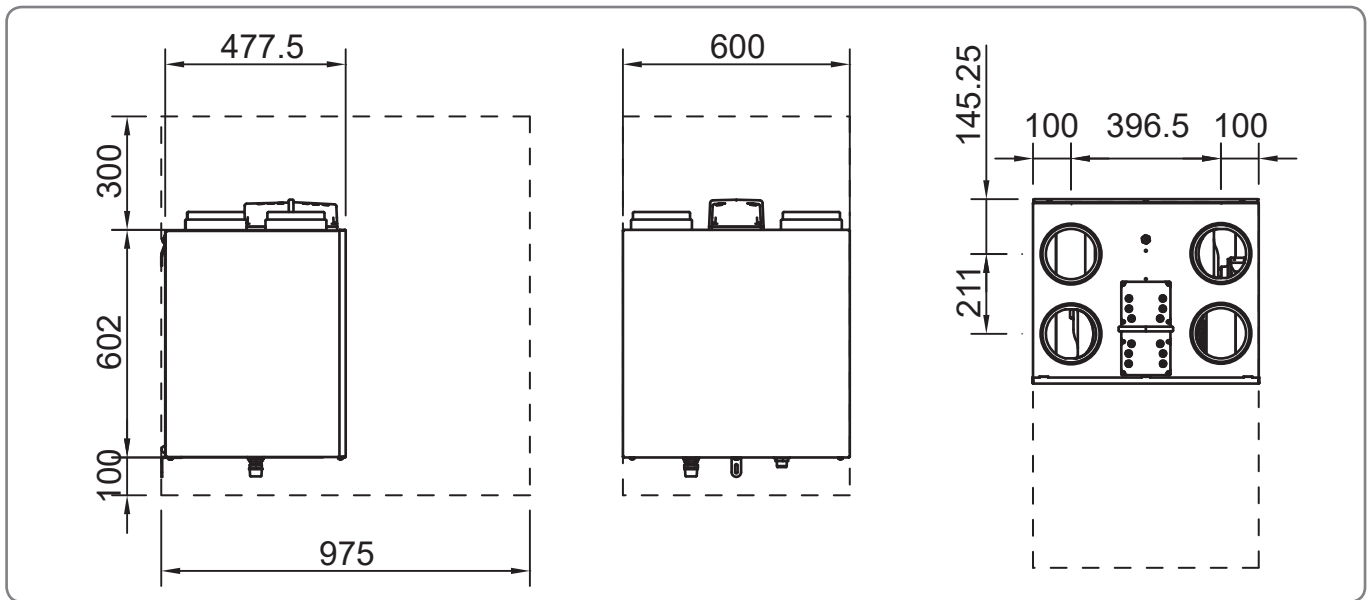

HRV4, 4.1 & 4.25 Q Plus

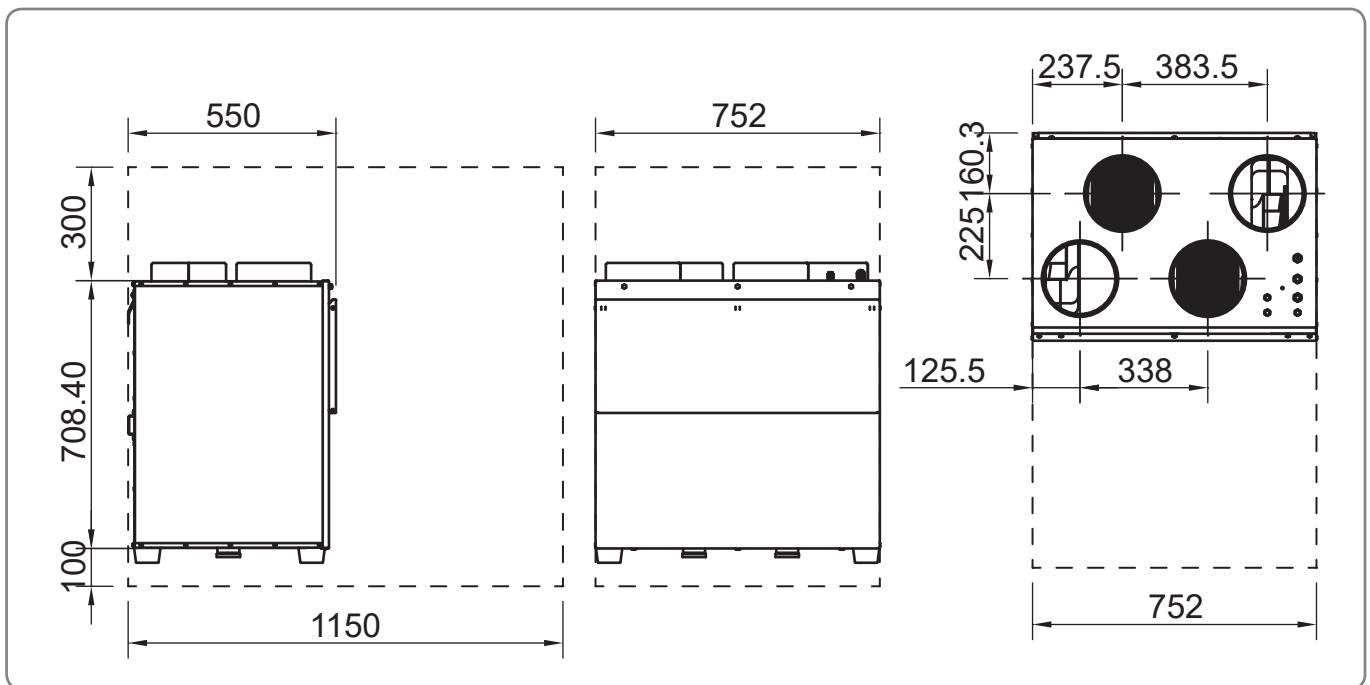

HRV20 Q Plus

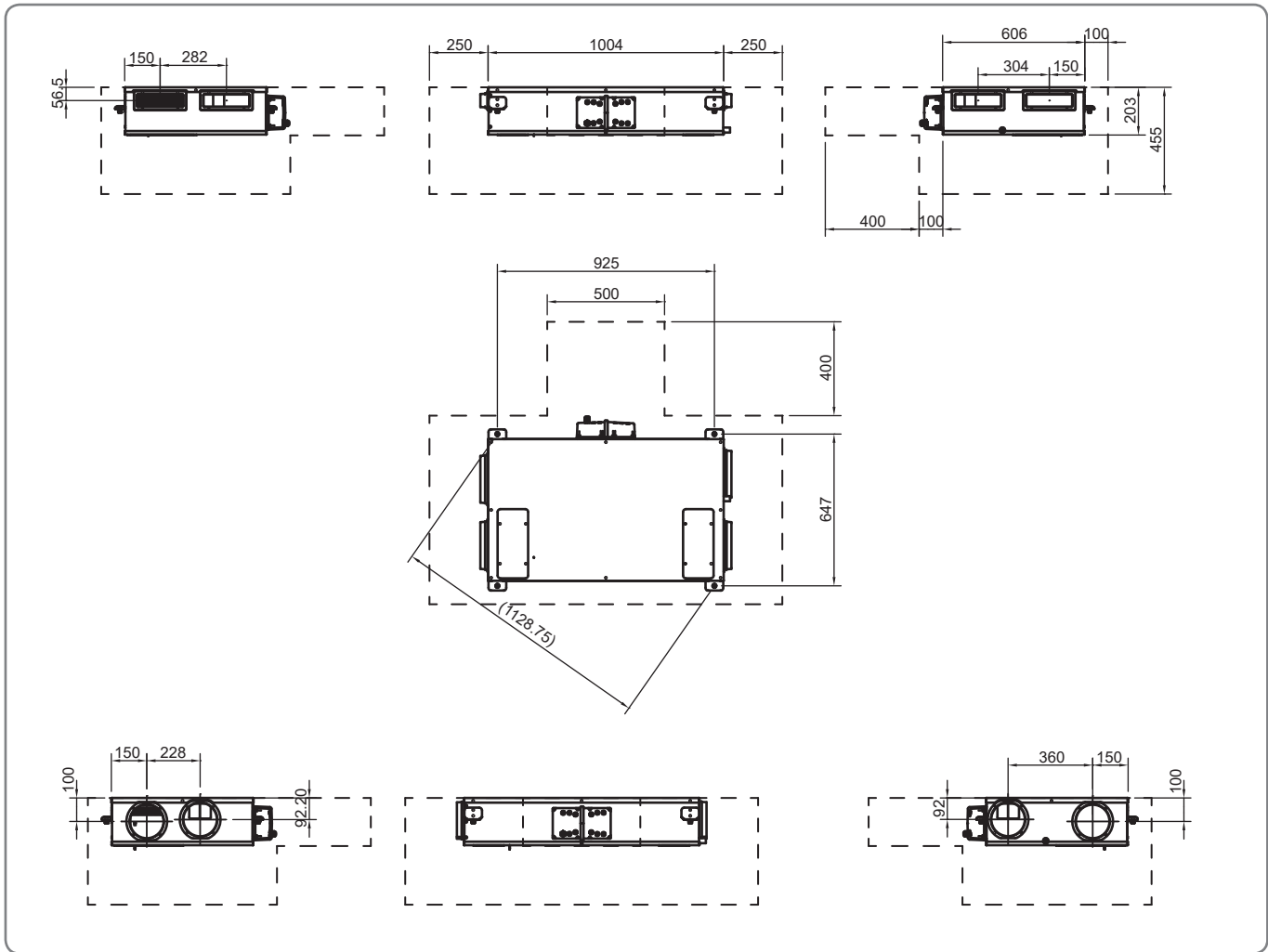

H200 Q Plus (Horizontal Unit)

Product Features

The following describes the controls and features of the auralite HRV *Q Plus* units and how they are controlled. Ensure all controls are adequately labelled, indicating their function clearly.

Filter Covers

The units are fitted with removable filter covers on the front panel.

auralite®

auralite® is available separately as an optional add-on. auralite® is a low voltage hard wired remote LED ventilation system status indicator, designed to fit a standard UK patress or recessed backbox. The indicator has six LEDs which display:-

- Normal Solid light - Unit is running at Continuous Speed.
Flashing light - Unit is running at Setback Speed.
- Frost Unit is in Automatic Frost Protection mode.
- Filter Filters require change.

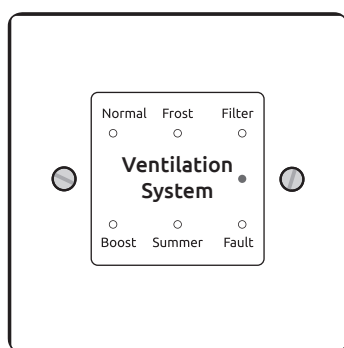

- Boost Solid light - Unit is running at Boost Speed.
Flashing light Boost Alert is active.
- Summer Unit is in Summer bypass.
- Fault Unit has a fault - Contact the installer.

Auto Setback Speed

Setback Speed is used to reduce ventilation rates. Setback Speed is automatically set at the mid point between minimum possible Continuous Speed and the selected Continuous Speed. The Setback Speed can be enabled by connection of a volt free one-way switch, or combined with the Boost Speed with the 3 position switch TP 508.

Continuous Speed

Continuous Speed is the normal continuous extract and supply air flow running speed of the units.

Boost Speed with Overrun Timer

Boost Speed increases the extract and supply air flow. Boost Speed is configured with Step-less independent fan controls and includes an Overrun Timer variable between 0 and 60 minutes. The Boost Speed can be triggered by any device which provides a volt free one-way switch, such as a PIR, thermostat, humidistat or a standard one-way switch. If the unit is left Boost (latching switch) for longer than 2 hours the Overrun Timer is disabled meaning the HRV will return to Continuous Speed as soon as the switch holding the unit in Boost is released.

auralite® Boost Alert

Boost Alert is a timer designed to prevent the HRV being inadvertently left in Boost for long periods of time. Once the HRV is placed in Boost the timer is started and after 2 hours Boost Alert will be activated. This is indicated by the Boost LED on the auralite® Indicator Panel flashing. Once Boost Alert has been activated the Overrun Timer is disabled meaning the HRV will return to Continuous Speed as soon as the switch holding the unit in Boost is released.

Summer Bypass

Summer Bypass is designed to operate during hot periods where fresh air can be vented straight into the property without being preheated by the extracted stale air. Summer Bypass operation is automatically controlled. The Summer Bypass mechanism diverts the stale air being extracted from the dwelling around the heat cell so that its heat energy is not transferred to the fresh air being supplied to the property.

SUMMERboost®

An optional SUMMERboost® facility is available that allows both the supply and extract fans to run at full speed whenever the Summer Bypass is activated.

By default SUMMERboost® is disabled by a Link Wire, see Wiring Diagrams.

Removal of the link wire will enable SUMMERboost®.

When SUMMERboost® is triggered by Summer Bypass the increased fan speed can be prevented either Manually or Automatically.

Manual - This is by means of a volt-free switch wired directly into the controller PCB.

Automatic - This is by means of a dedicated wall mounted room thermostat.

SUMMERboost® will only operate when the temperature has exceeded the thermostat setting.

Should the room temperature fall below the thermostat setting, then

SUMMERboost® will not operate.

Automatic Frost Protection

During very cold weather, Automatic Frost Protection will detect temperatures that could form ice inside the unit. It will reduce the supply ventilation rate to prevent ice build up within the heat cell. Automatic Frost Protection reduces the flow rate of cold air, thus allowing the warmer stale air to raise the temperature within the heat cell to such a level that prevents the formation of ice. As

internal temperatures rise Automatic Frost Protection will increase the supply ventilation flow rate back to the commissioned settings.

Integrated Humidity Sensor

Units are fitted with an Integrated Humidity Sensor. This continuously monitors the relative humidity (RH) of the extracted air and triggers Boost Speed when the relative humidity rises over the set threshold. The Humidity Sensor's trigger point is variable from 55%RH to 85%RH and is configured using step-less independent potentiometer.

Enthalpy humidity-recovery

Units with the E suffix use an enthalpy heat recovery core that recovers some of the humidity as well as heat.

Installation

Unit Mounting

Read and observe the guidance & safety notices listed in Warnings, Safety Information and Guidance .

Do not remove the Port Covers, where fitted, until connecting ducting. Port Covers are fitted to prevent debris falling into the unit and causing blockages and damage:

- The mounting surface must be sufficiently strong to support the unit.
- Consider the positioning of electrical services and the Condensate Drain when siting the unit.
- Ensure there is sufficient access around the HRV Q **Plus** (Service Void - - -) for future maintenance; see Units' Dimensions Section for details.
- Do not 'box-in' the unit making access to the unit difficult for maintenance and repair. (Duct Covers are available)

The Unit Must be mounted plumb and level front to back and side to side.

All Units except H200

1. Mark a horizontal line on the wall using a spirit level. This line will be approximately
95mmHRV1.3, 1.35, 1.6, 1.65, & 4, 4.1 & 4.25 Q Plus
110mm.....HRV20 Q Plus
below the location of the top face of the unit when fitted (excluding duct ports).
2. Use the Mounting Brackets as a template to mark the three fixing hole centres.
3. Drill holes for fixings, always use a fixing suited to the wall type.
4. Fix the Mounting Bracket to the wall ensuring the interlocking side is at the top; as shown. Mount the unit by locating the two mounting Brackets together.
5. Ensure a positive location is made between the two Mounting Brackets.

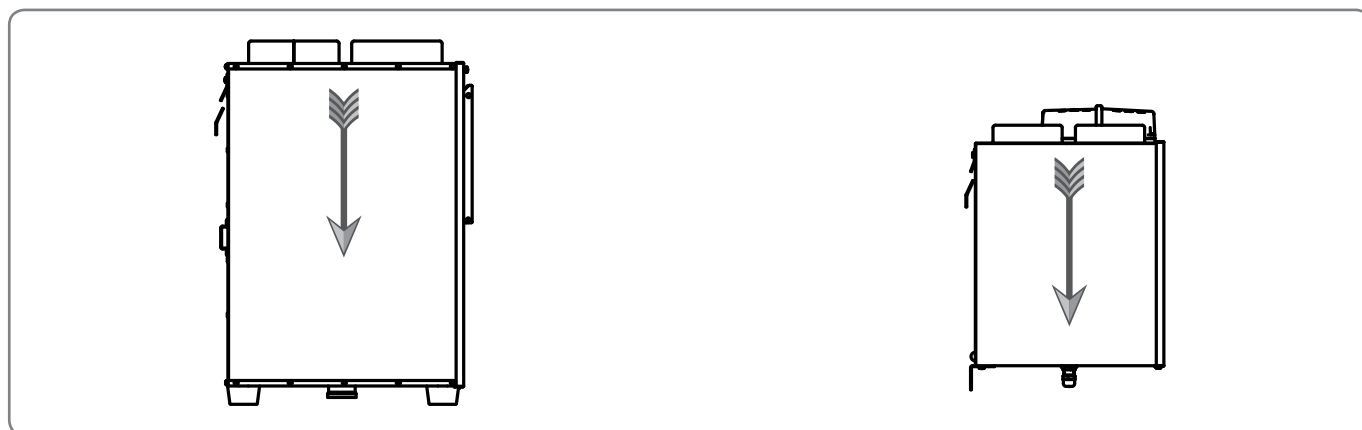
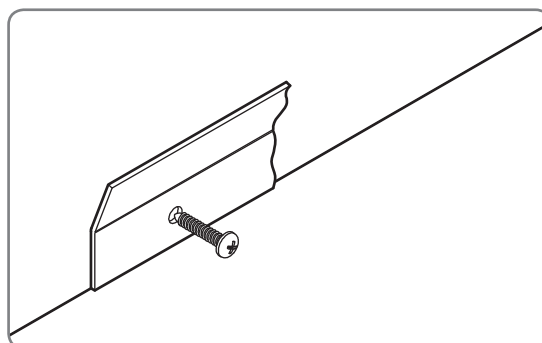

Hook Unit onto Wall Bracket

Safety Bracket

The Safety Bracket(s) **MUST** be used.

HRV20

1. Remove the rear Transport Feet to enable fitment of the Safety Brackets and remove the front Transport Feet and M6x40mm fixing screw and discard. Fit the supplied M6x10mm screws from the Safety Bracket Pack.
2. The Safety Brackets **MUST** be fitted. Fix the lower Safety Brackets as shown using the remaining M6 screws, washer and suitable wall fixing. Packing to be used as required behind the Safety Bracket to ensure unit is level.

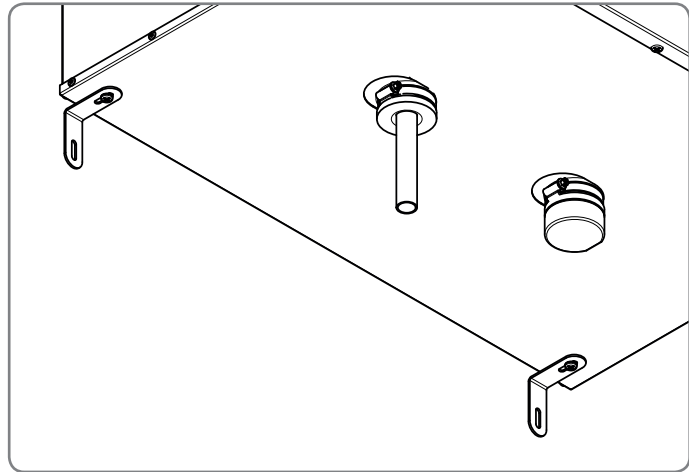

Other Units

- Fix the lower Safety Bracket as shown using the remaining M6 screw, washer and suitable wall fixing. Packing to be used as required behind the Safety Bracket to ensure unit is level

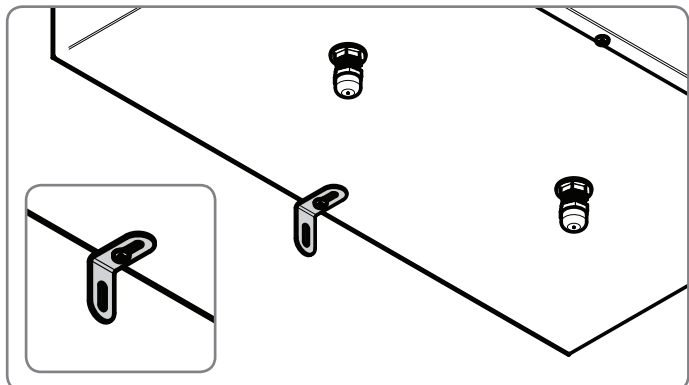

Mounting H200

Read and observe the guidance & safety notices listed in Warnings, Safety Information and Guidance .

- The units are designed to be mounted on the underside of a horizontal surface.
- The mounting surface and fixings must be sufficiently strong to support the unit. The H200 unit is 32Kg,
- Consider the positioning of electrical services and the Condensate Drain when siting the unit.
- Ensure there is sufficient access around the HRV Q Plus (Service Void ---) for future maintenance; see Units' Dimensions Section for details.
- Do not 'box-in' the unit making access to the unit difficult for maintenance and repair.

The unit must be mounted plumb and level front to back and side to side.

1. Position four Ø8mm fixings in the mounting surface in the positions specified. Fixings must be suitable for the mounting surface substrate and the weight of the unit. Fixings are not supplied due to the variation in materials. For advice on suitable fixings contact your local specialized fixings dealer.

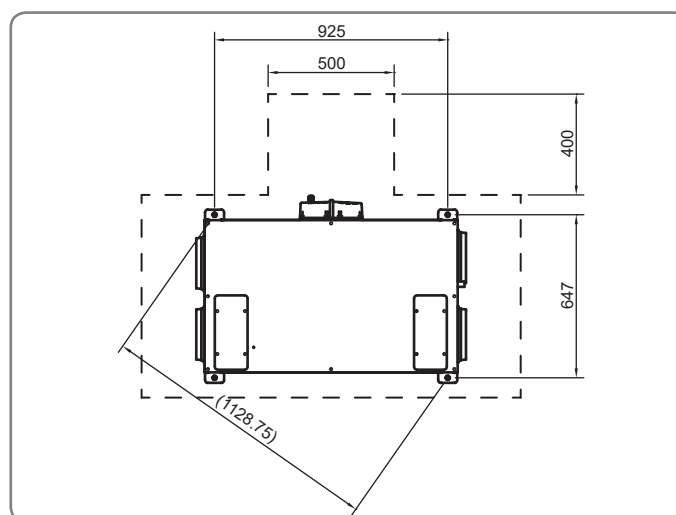

Locations of Fixings

2. Fit the 4 mounting brackets to the sides of the unit with the M5 screws and M5 star washers, ensure all mounting brackets are orientated as illustrated.
3. Secure the unit using Ø8mm fixings. Ensure the unit is plumb and level front to back and side to side.

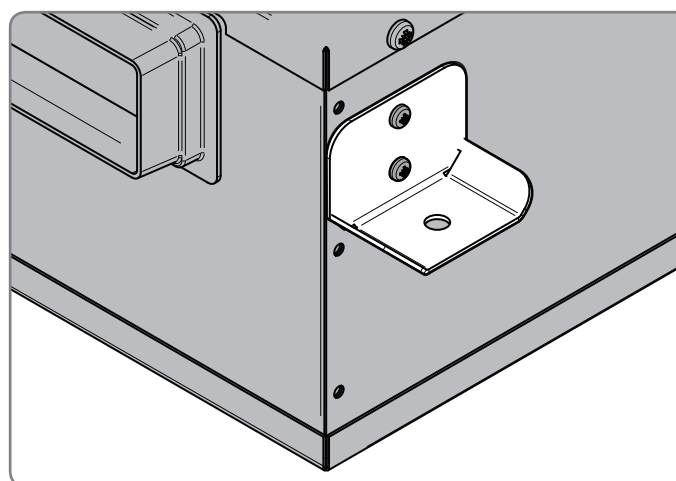

Orientation of Mounting Bracket

Condensate Drain

The unit's Condensation Drain Pipe must be fitted and connected to the dwelling's foul water drainage system in accordance with the relevant building regulations.

The Condensate Drain:

- Must incorporate a suitable trap, which must act as an air lock, ie must be sealed.
- Must be adequately secured along its length.
- Must be insulated if any part of the pipe passes through a unheated void or a space which could fall below 10°C.
- Must be installed to have a 3 to 5° fall from the unit.
- Titon recommend the use of a diaphragm type waste valve, in place of a conventional 'wet' trap which could dry out; Such as a 'Hepworth HepvO® Hygienic self sealing plastic waste valve' recommended as an alternative to traditional U-Traps (BRE certificate no. 042/97).

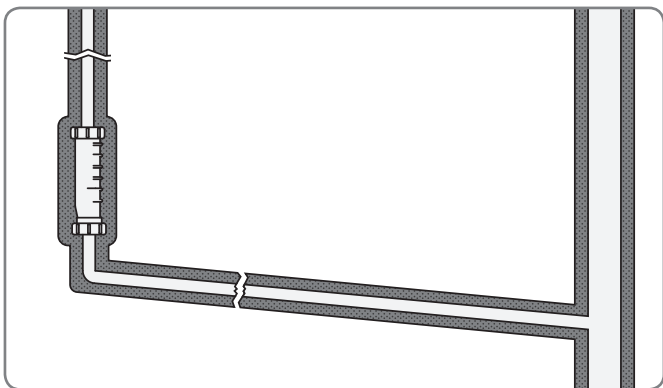

Insulated Self Sealing Trap and Waste

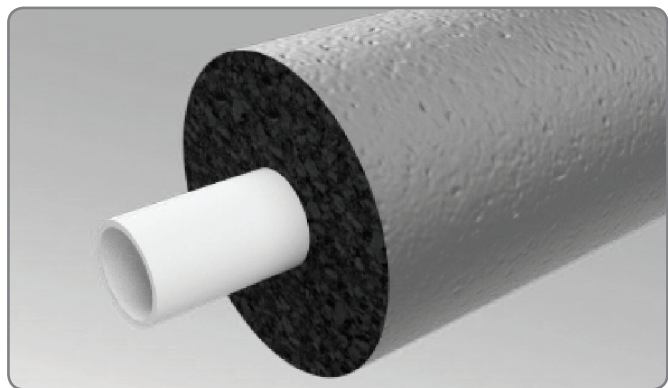

Insulated Condensate Drain

Other than the H200 all units are supplied as either Left Hand, Right Hand Units.

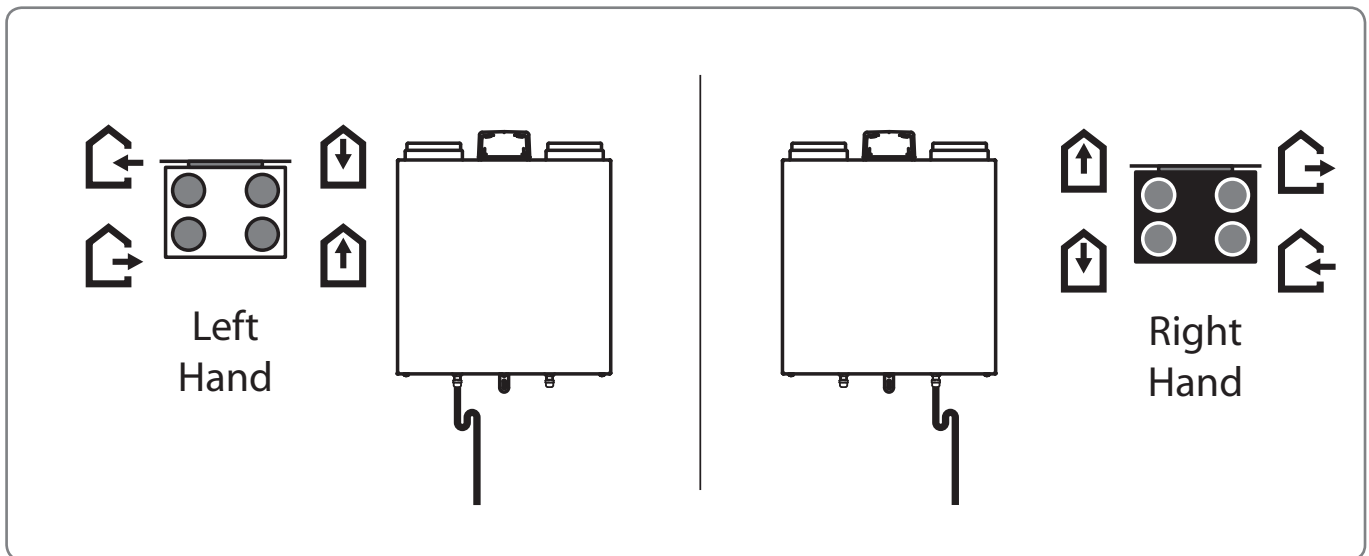

Left / Right Hand Drain Connection & corresponding Ducting Connections

HRV1.3 & 1.35

The Condensation Drain Pipe Is attached via a 15mm compression fitting

HRV 1.6 1.65, 4, 4.1 & 4.25

Condensation Drain Pipe Is attached via a 22mm compression fitting.



Condensate Outlet



Blanking Plate fitted to unused Outlet

Blanking Plug

The Blanking plug is fitted to the unused condensate outlet.

HRV20

1. Fit hose clamps around both Condensate Drain Sockets, ensuring they are pushed over the lip and aligned with recess in sheet metal casing
2. Insert 22mm O/D PVC pipe into Condensate Drain Socket up to the stop, no more than 35mm of pipe should be inserted into Condensate Drain Socket.
3. Insert Condensate Bung fully into opposite Condensate Drain Socket.
4. Hand tighten the hose clips. Do not over tighten.

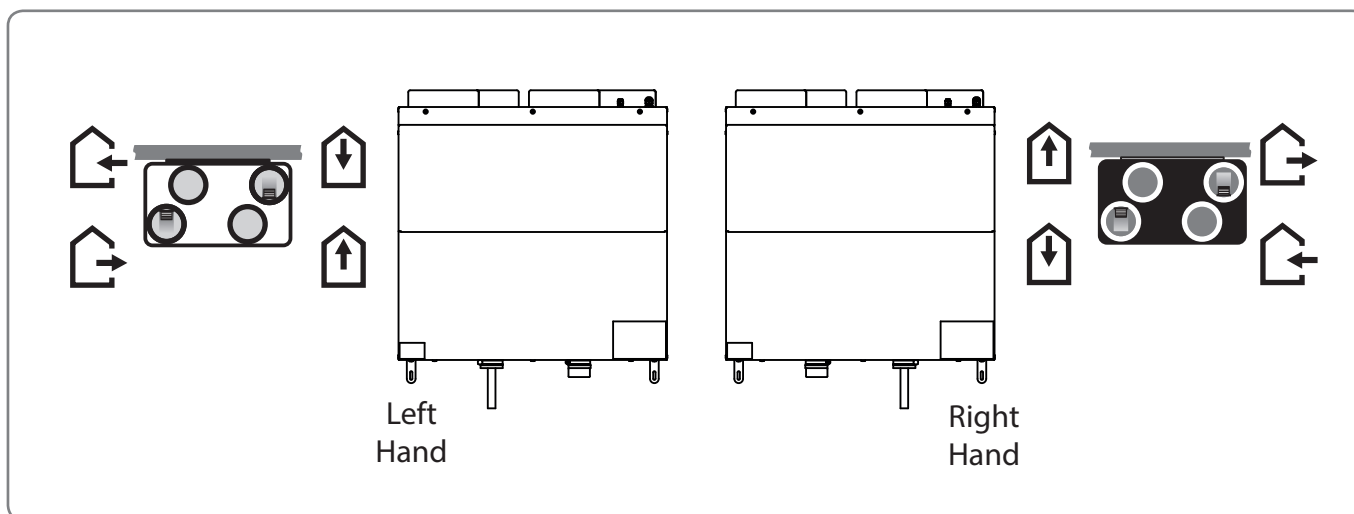

Left / Right Hand Drain Connection & corresponding Ducting Connections

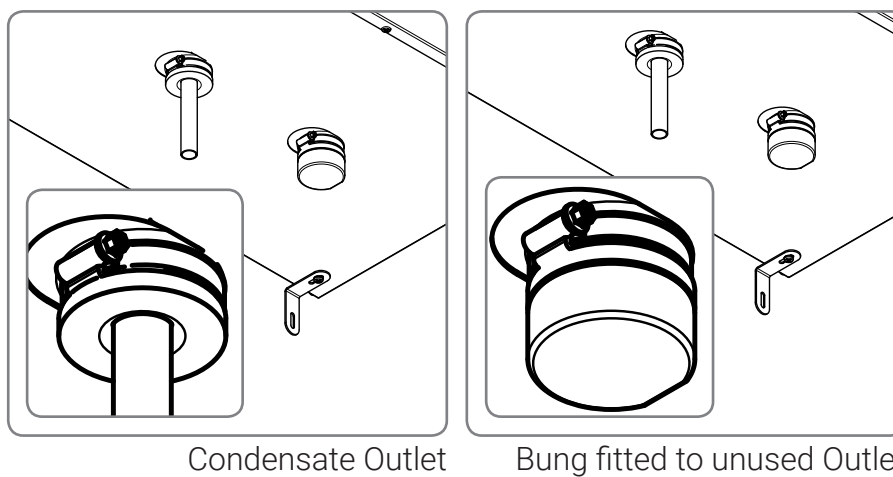

Horizontal Unit(s)

H200

The H200 is only available with one port configuration.

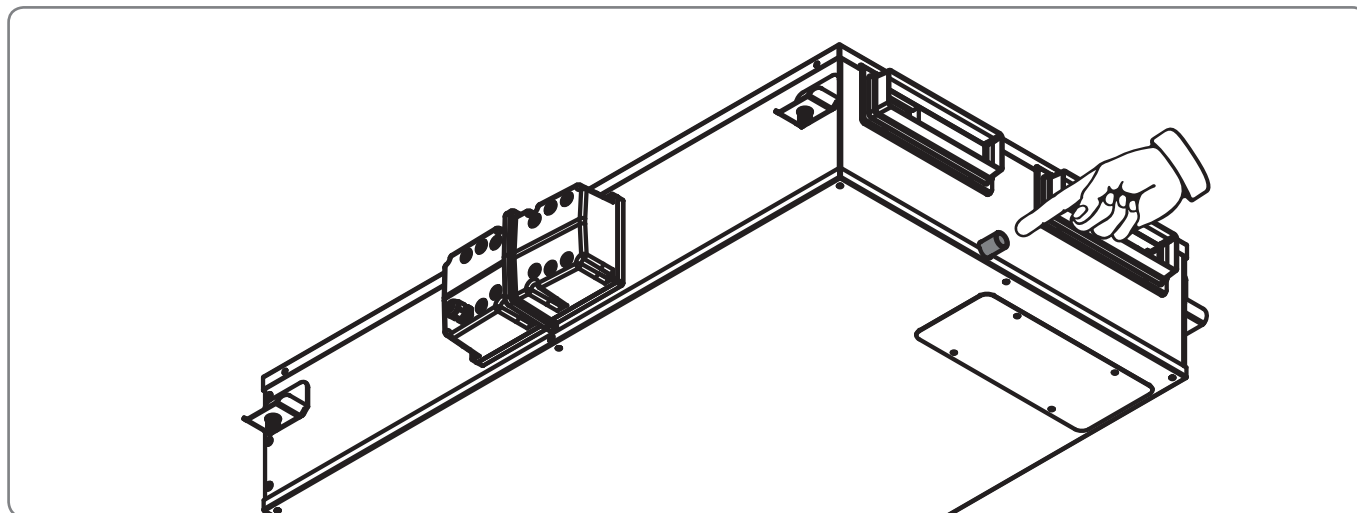

Condensate Drain Highlighted

- Condensate output is a $\text{Ø}21.4\text{mm}$ plastic pipe positioned on the end of the unit.
- Drain pipe must be fitted to the unit with a removable fitting.

Ducting Connections

The HRV unit has a labels with the icons indicating which port is which.

Read and observe the Warnings, Safety Information and Guidance.

It is very important that ducting is connected to the correct ports in line with the icons below.

Port Designations



EXTRACT FROM DWELLING - This duct port is connected to the ducting that carries waste air from the 'Wet Rooms' to the HRV unit.



TO ATMOSPHERE - This duct port is connected to the ducting that carries the waste air to outdoors from the HRV unit.



SUPPLY TO DWELLING - This duct port is connected to the ducting that carries the fresh warmed air to the habitable rooms from the HRV unit.



FROM ATMOSPHERE - This duct port is connected to the ducting that carries fresh outdoor air to the HRV unit.

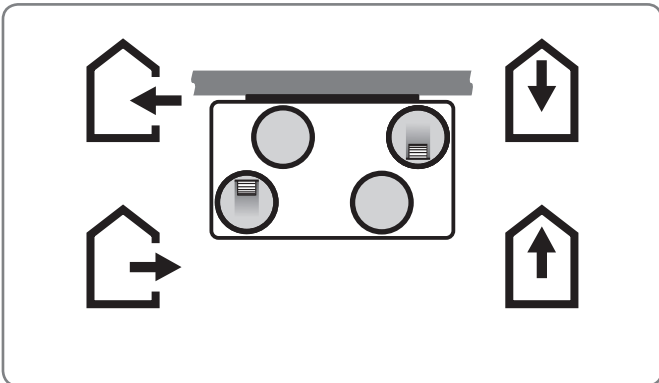

Left Hand Units' Duct Connections

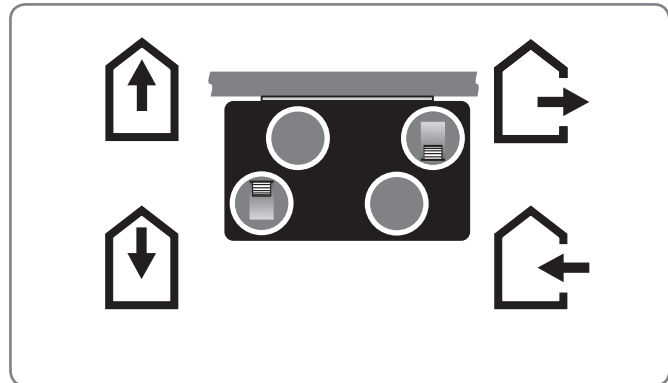

Right Hand Units' Duct Connections

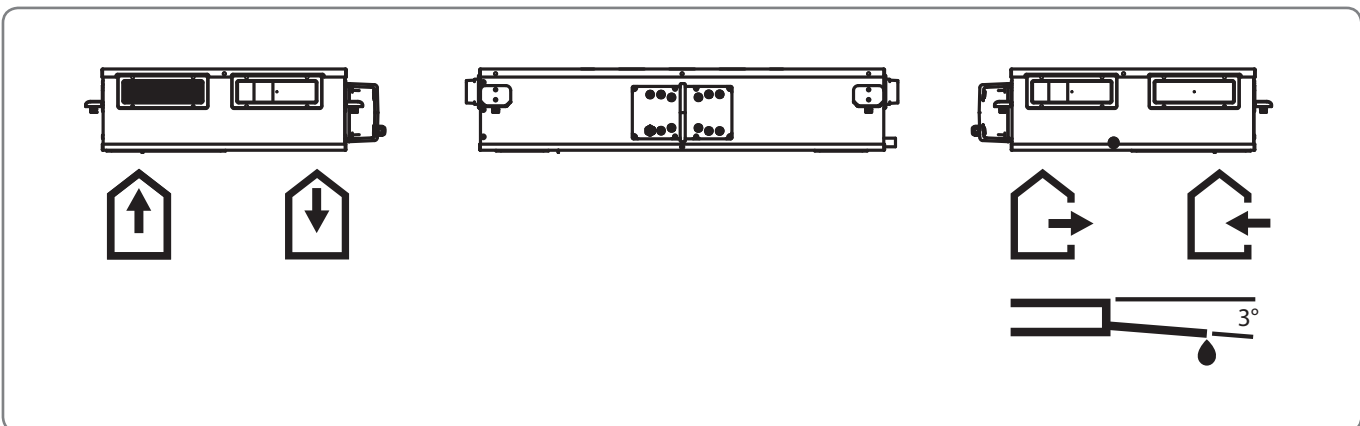

H200 Duct Connections

Wiring

Wiring Access

All wiring must conform to current I.E.E. Wiring Regulations and all applicable national standards and Building Regulations.

Read and observe the Warnings, Safety Information and Guidance.

With the exception of the HRV20 all units use the same Electronics Terminal Enclosure. The compartment has two removable lids. The front (Right - H200) lid must always be removed before the rear lid; both lids are fixed by four screws. All wiring must be routed into the electronics compartment using cable glands or similar.

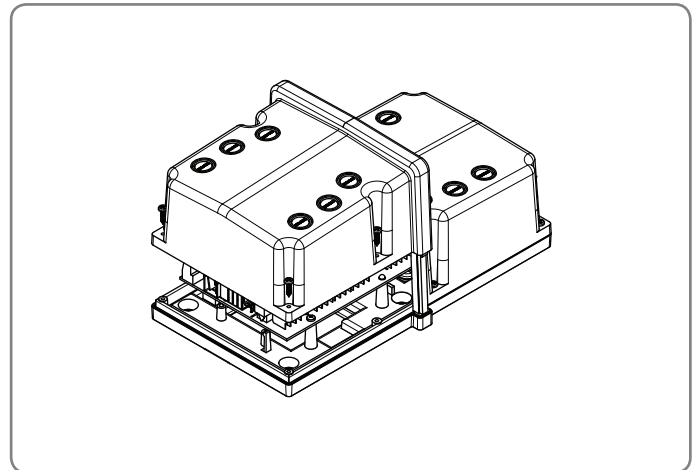

Electronics Terminal Enclosure

HRV20

To access the electronics compartment remove the Front Panel of the unit (see Maintenance section) and partially slide out the electronics tray.

Supply

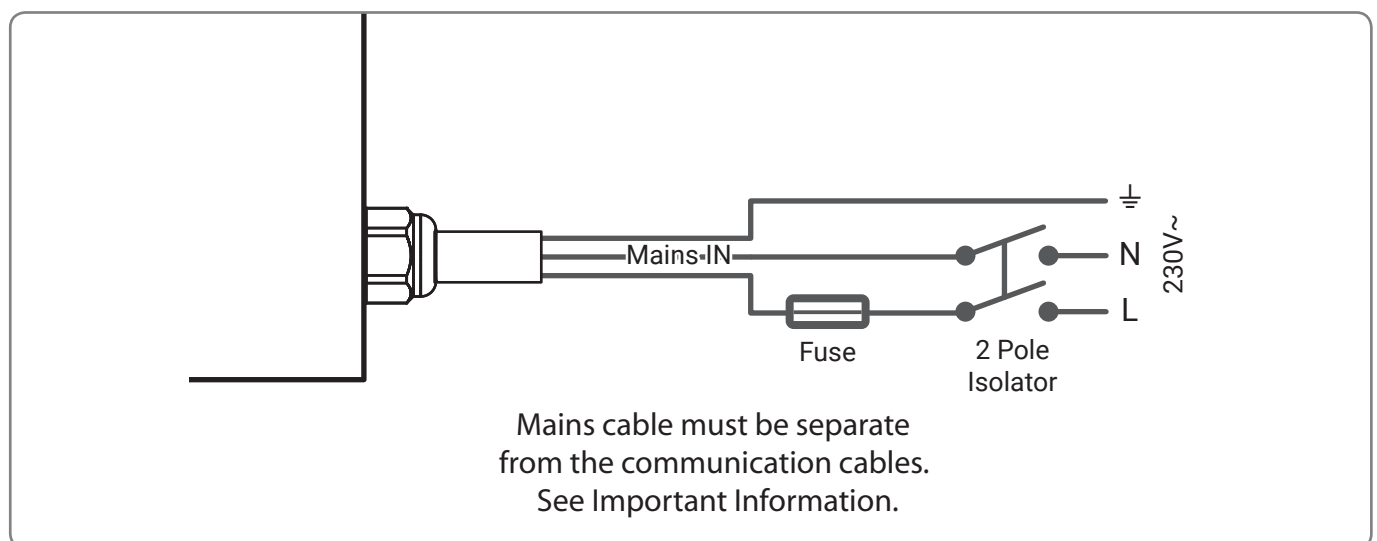

Supply Wiring

auralite®

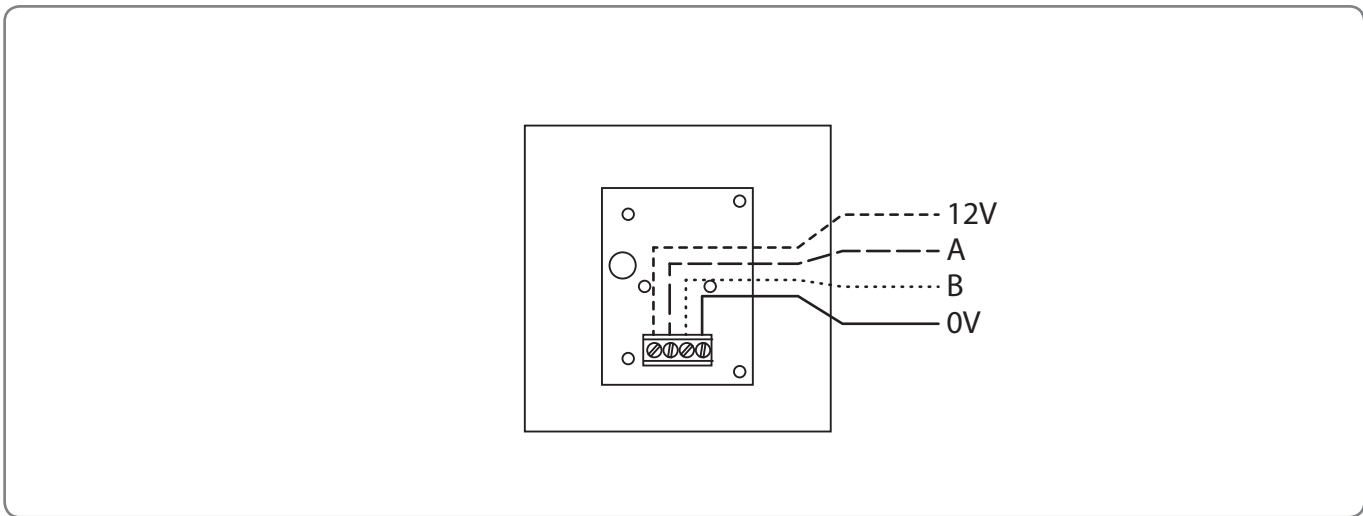

auralite® connection at Indicator ref EE180

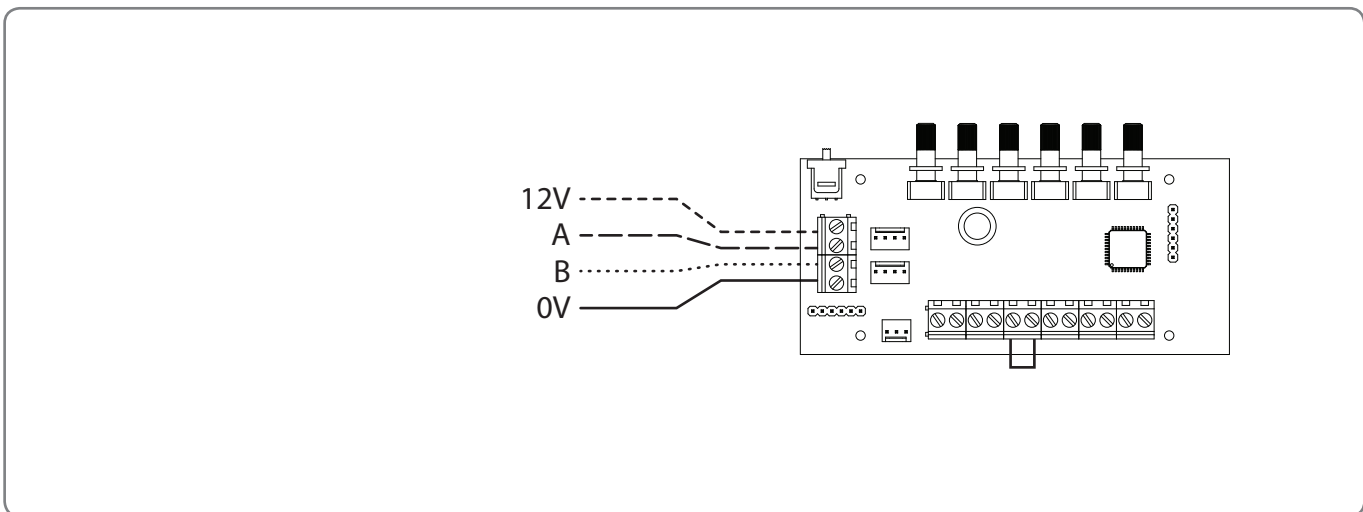

auralite® connection at Unit ref EE180

Switching & Controls

Volt-free control of SUMMERboost® using one way latching switch.

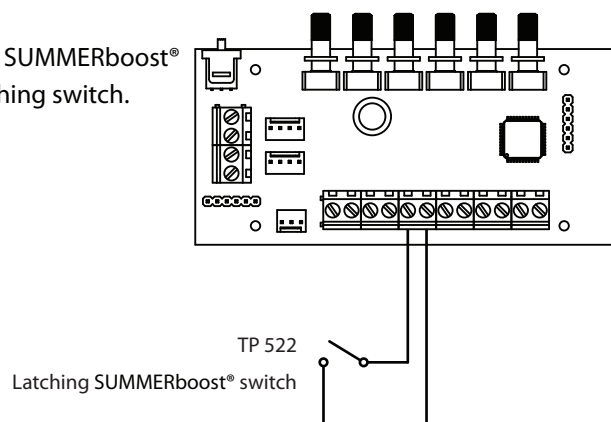

SUMMERboost® switch connection ref EE178

Volt-free boost switching of MVHR controller PCB using single-pole switches TP 502, TP 503, TP 507 and / or TP500 / TP501 humidistat.

There is maximum of 10 single pole switches or humidistats that can be used.

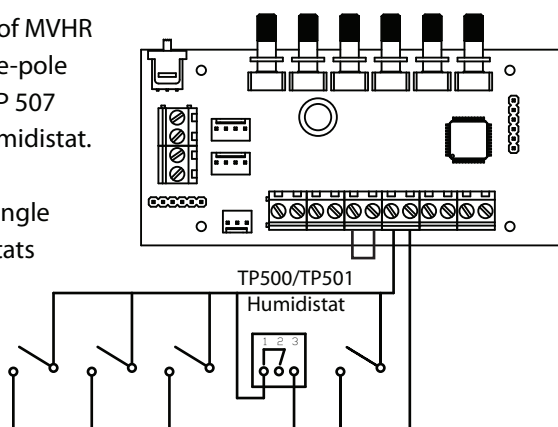

Boost switching and humidistat connection ref EE173

Volt-free setback switching of MVHR controller PCB using single-pole latching switch and / or volt-free normally open relay contacts.

To avoid the unit being inadvertently left in Setback Mode, it is recommended that only one latching switch is fitted.

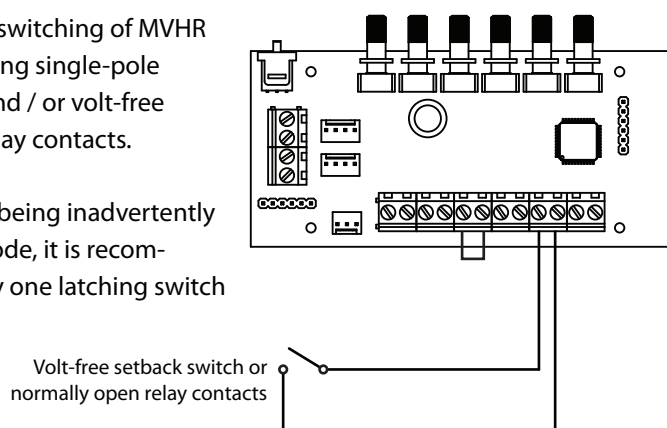

Setback Mode switching and connection ref EE177

SWITCH POSITIONS

- 1 - Setback Speed
- 2 - Continuous Speed
- 3 - Boost Speed

TP 508
Three position rotary switch

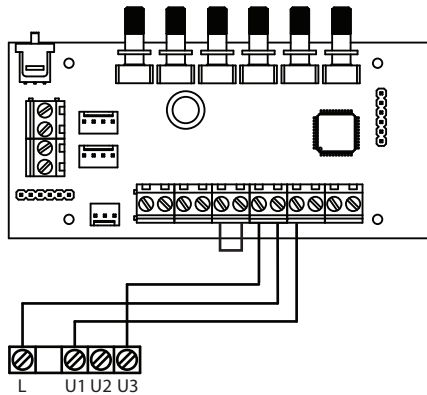

Three Position Rotary Switch TP 508 switching and connection ref EE175

SUMMERboost® Link Wire must be removed to enable SUMMERboost®.

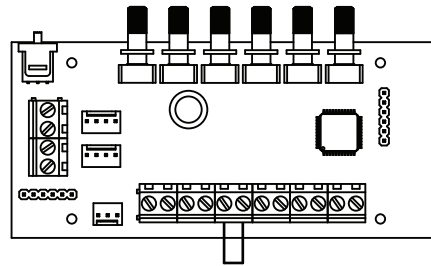

SUMMERboost® Link Wire

SUMMERboost® Link Wire

Volt-free control of SUMMERboost® using room thermostat.

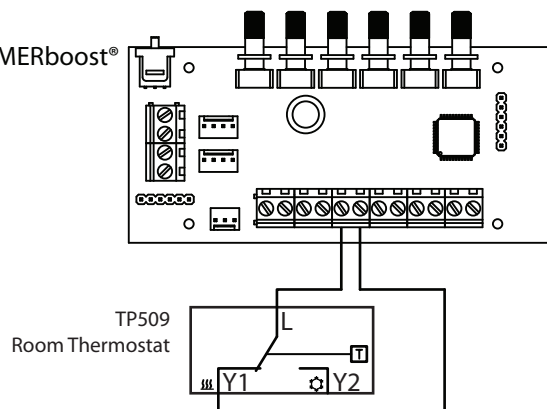

TP509
Room Thermostat

SUMMERboost® thermostat connection ref EE178

Commissioning

Controls

The fan speeds of the Titon HRV *Q Plus* will require adjustment to ensure the flow rates achieved provide adequate ventilation. The Titon HRV *Q Plus* has 2 standard fan speed settings Continuous Speed and Boost Speed.

The Continuous Speed and Boost Speed are programmed by placing the controller into Program Mode via the Program/Run Switch and changing the position of rotary potentiometers.

When applying power for the first time, the unit can take up to four minutes to start operating. Prior to the first commission set Continuous Speed potentiometers to minimum and Boost Speed potentiometers to maximum or reset the controller.

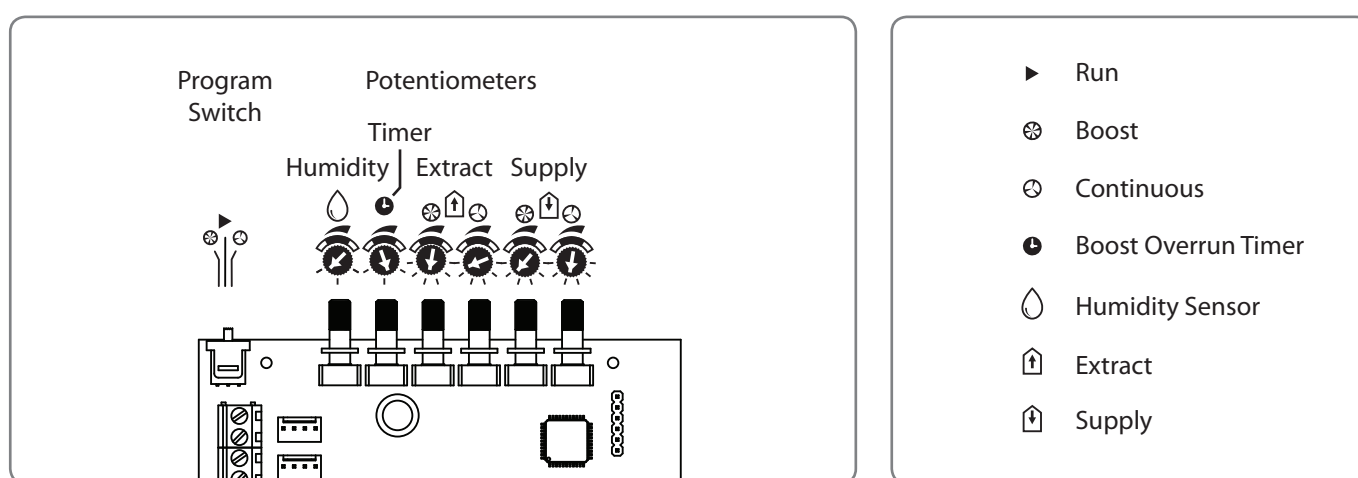

Control Identification

Control Parameters

- The Boost Speed cannot be set lower than the Continuous Speed.
- The Continuous Speed cannot be set higher than the Boost Speed.
- All switching inputs are disabled when the Program/Run Switch is in Continuous or Boost positions.
- Speed control potentiometers are disabled when the Program/Run switch is in centre Run position.

For the commissioning settings to be stored the unit needs to be powered up.

Continuous Supply & Extract Speeds:

1. Move Program/Run Switch to Continuous position.
2. Rotate supply fan Continuous Speed adjustment potentiometer to achieve required supply continuous air flow.
3. Rotate extract fan Continuous Speed adjustment potentiometer to achieve required extract continuous air flow.
4. Return Program/Run Switch to centre position to exit commissioning.

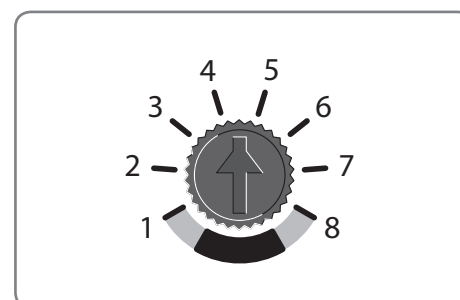

Commissioning Pot positions

Boost Supply & Extract Speeds:

1. Move Program/ Run Switch to Boost position.
2. Rotate supply fan Boost Speed adjustment potentiometer to achieve required supply boost air flow.
3. Rotate extract fan Boost Speed adjustment potentiometer to achieve required extract boost air flow.
4. Return Program/Run Switch to centre position to exit commissioning.

Boost Overrun

Boost Overrun Timer is variable between 0 and 60 minutes. Rotate potentiometer to change overrun time. This can be done at any time.

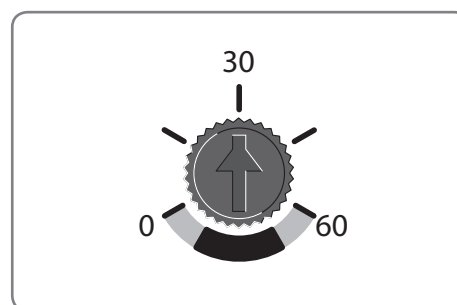

Humidity Sensor

The Humidity Sensor's trigger point is variable from 55%RH to 85%RH. Rotate potentiometer to change trigger point. Humidity Sensor adjustment can be done at any time without the need to move the Program / Run Header Link.

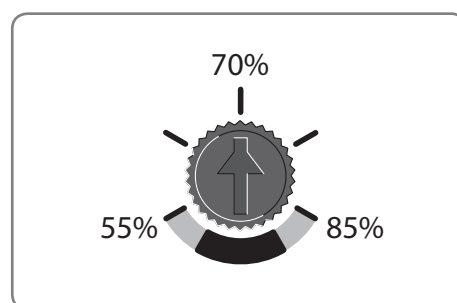

Controller Reset

Following a controller reset the ventilation system will need to be fully commissioned.

The procedure to reset the Titon HRV *Q Plus* controller is a simple three step operation. The unit will need to be powered up during the reset procedure.

1. Rotate the Supply and Extract Continuous Speed potentiometers fully anti-clockwise.
2. Rotate Supply and Extract Boost Speed potentiometers fully clockwise move the Run/ Program Switch from the Run position to the Continuous position, from the Continuous position to the Boost position and back to the Run position. To ensure that the reset switch movements are registered by the controller wait two seconds between each switch movement. Controller reset is now complete.

Hardware Reset

Certain conditions (repeated supply interruptions etc.) can activate the automatic motor protection mode. Whereby the fan motors are prevented from operating. This requires a hardware reset to return the unit to normal operating mode, to achieve this power to the unit should be switched off for 5 minutes, restoring the power after this time will reset the hardware of both the motor and PCB. Commissioning settings are not affected during a hardware reset.

Maintenance

Routine Maintenance

All ventilation units require periodic maintenance. Routine maintenance, apart from filter changes, must only be carried out by a suitably qualified and competent person.

WARNING: The unit uses a ~230V supply and contains rotating mechanical parts.

ISOLATE the unit from mains power supply and allow sufficient time for all moving parts to stop before undertaking any Servicing or Maintenance.

The unit may be supplied with multiple live supplies if a Duct Heater is fitted or uses switched live for Boost Speed control.

Cleaning Exterior

For best results use a clean damp cloth. Do not use abrasive cleaners, solvents or any other fluids.

Cleaning Interior

For best results:

1. Slide out the Filters.
2. Carefully remove any dust from face of heat exchanger, interior of the unit and the Bypass using a vacuum cleaner

Do not use water or any other fluids

HRV1.3, 1.35, 1.6, 1.65, 4, 4.1 & 4.25

Front Cover Removal

1. ISOLATE the unit from mains power supply and allow sufficient time for all moving parts to stop
2. Loosen the two corner screws located on the bottom front of the unit
3. Completely remove the centre screw
4. Completely remove the Front Cover by pulling it away from the unit at the bottom and lifting

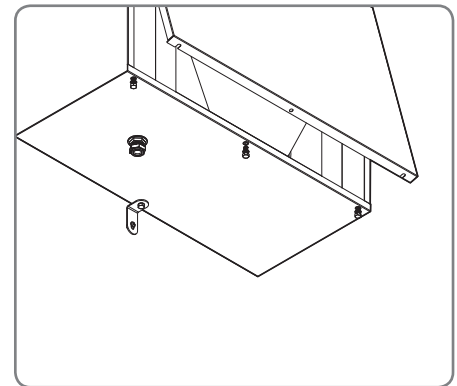

Cover replacement is the reverse of the above steps. Ensure it is securely located at the top before tightening screws.

Condensate Tray

If the Condensate Tray is split a replacement must be ordered and fitted.

HRV1, 1.25, 1.3 & 1.35 Q Plus	Part No. XP40042/012
HRV1.6 & 1.65 Q Plus	Part No. XP4010649/012
HRV4	Part No. XP

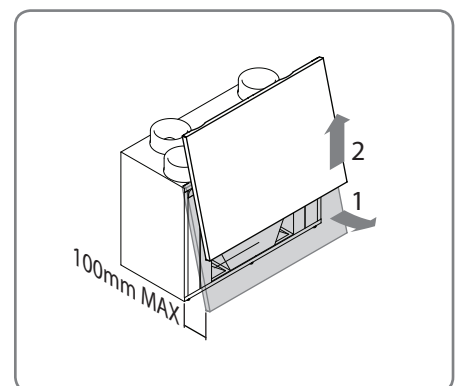

HRV20

Front Cover Removal

1. ISOLATE the unit from mains power supply and allow sufficient time for all moving parts to stop
2. Loosen the two corner screws located on the bottom front of the unit
3. Completely remove the centre screw.
4. Completely remove Front Cover top cap nuts.
5. Completely remove the Front Cover by pulling it away from the unit at the bottom and lifting
6. Cover replacement is the reverse of the above steps. Ensure it is securely located before tightening screws.

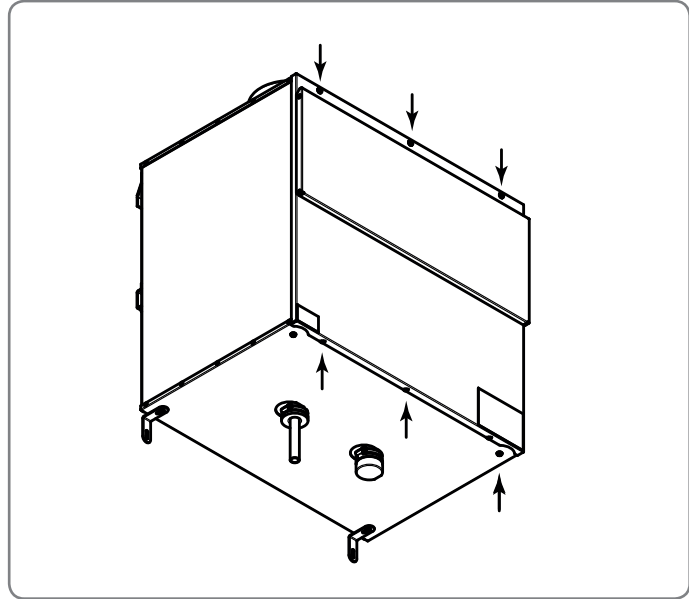

H200

Access to Interior for cleaning

1. ISOLATE the unit from mains power supply and allow sufficient time for all moving parts to stop.
2. Remove Condensate Drain Pipe from the unit using the removable fitting.
3. Remove the Front Cover, Front Cover is attached with 8 screws.
4. Remove the black ribbed panel.
5. Remove the Condensate Tray Retaining Strap by rotating as indicated.
6. Carefully slide the Condensate Tray towards the centre of the unit until the Condensate Tray Drain Spigot is clear of the case.
7. Heat Cell can be removed by pulling the strap downwards.
8. Reassembly is the reverse of the above steps.

Filter Replacement

Filters should be replaced at least annually, or more regularly dependent on environmental conditions. The connected controller will indicate filter change required in line with the Filter Change Interval settings.

Replacement Filters are available from Titon Direct. www.titondirect.co.uk

Filters should be replaced with like for like components.

Following filter replacement the HRV controller's Filter Warning should be reset, refer to Product Manual of controller for details.

HRV 1.25, 1.3, 1.35, 1.6, 1.65, 4, 4.1 & 4.25

The Filters are available in different grades G3, G4 & F7. Filter media should be replaced like for like. Filter Part numbers in table below.

G3 Filters - Both faces white.

G4 Filters - One face white, one face blue.

Model	G3 Filter Set 2 framed filters	G4 Filters Set 2 framed filters	G4 Panel Filters Set	F7 Single Panel Filter	G4 & G7 Panel Filter Set
HRV1.25 Q Plus	XP40032	XP46022			
HRV1.3 Q Plus					
HRV1.35 Q Plus					
HRV1.6 Q Plus	XP2010671	XP2010897			
HRV1.65 Q Plus					
HRV4 Q Plus			XP2011629	XP2011630	XP2011754

To replace filters.

1. Remove Filter Covers or open Filter Door.
2. Slide out Filters make note of any arrows on the filters.
3. Replace Filters by carefully sliding in the replacement filters. Ensure that filters are replaced in the same orientation as they were removed.
4. Replace the Front Cover or Filter Covers.

HRV20

Titon HRV20 **Q Plus** Filters are available in two grades G4 x 2 and G4 + F7. Filter media should be replaced like for like. When replacing G4 + F7 filters make a note of the relative positions of the filters before removing. Ensure the F7 and G4 filters are replaced in the same positions.

Filter Part numbers in table below.

Model	G4 x 2 Filter Set 2 pleated filters	G4 + F7 Filters Set 2 pleated filters
HRV20 <i>Q Plus</i>	XP2010561	XP2010929

To replace filters

1. Open Filter Cover door, the door is hinged at the bottom, pull from the top.
2. Slide out Filters.
3. Replace Filters by carefully sliding in the replacement filters. Ensure the F7 and G4 filters are replaced in the correct positions.
4. Close Filter Cover.

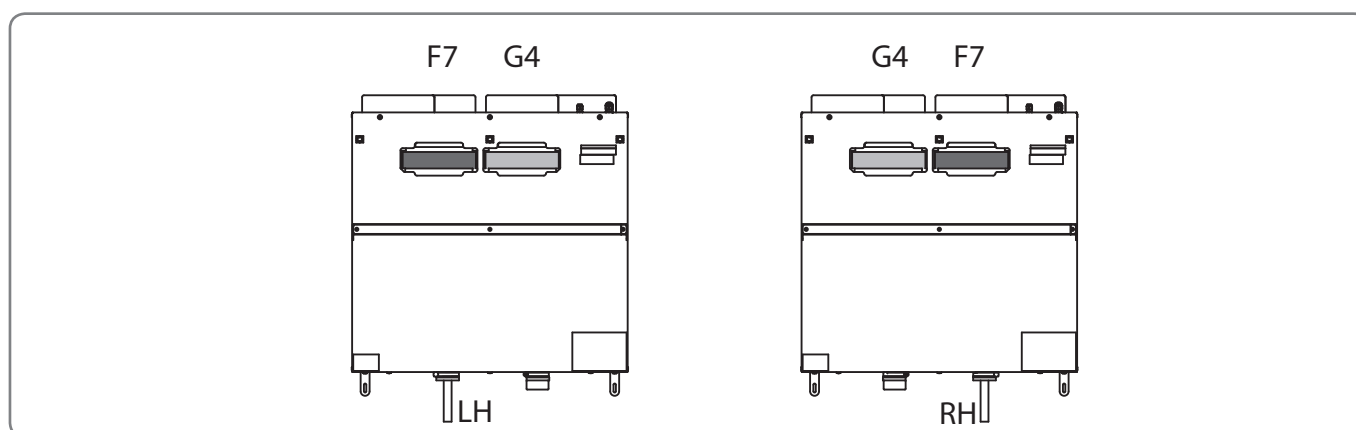

H200

The H200 can be specified with filters of different grades. Filters must be replaced with like for like replacements, failure to do so will result in changed system airflows and will necessitate the re-commissioning of the ventilation system.

Type	Part Number
2 Standard G4 panel filters	XP2010173
1 F7 panel filter & 1 G4 panel filter	XP2010174
1 Slim G4 pre-filter, optional for use with F7 filter	XP2010172

To replace filters.

1. Remove Filter Covers, each cover is attached with four screws.
2. Slide out Filters.
3. Replace Filters by carefully sliding the replacement.
4. If using cardboard framed pleated Filters ensure arrows printed on the ends of the Filters point towards the centre of the unit.
5. Replace Filter Covers. When refitting do not overtighten screws.

In the event of any queries please contact the system installer.
Ensure this booklet is passed to the householder once installation & commissioning of the ventilation system is complete.

This Product Manual must be kept in the Home Information Pack.



This symbol on this unit or the package, indicates that disposal of this unit after its life-cycle could harm the environment.

Do not dispose the unit as unsorted municipal waste; it should be disposed by a specialized company for recycling. This unit should be returned to your distributor or to a local recycling service. Respect the local environmental rules.



MARKETING DIVISION

894 The Crescent, Colchester Business Park, Colchester, CO4 9YQ

Tel: +44 (0) 1206 713800 Fax: +44 (0) 1206 543126

Email: ventsales@titon.co.uk Web: www.titon.com



Installed by: