

Electrical Details

External wiring for one room ventilation

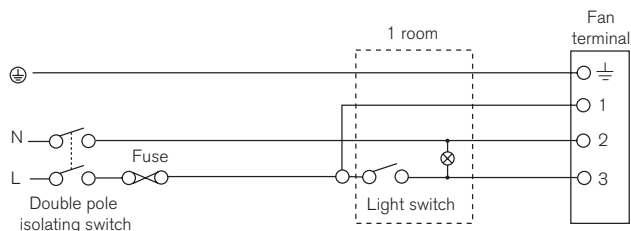

External wiring for two room ventilation light operation

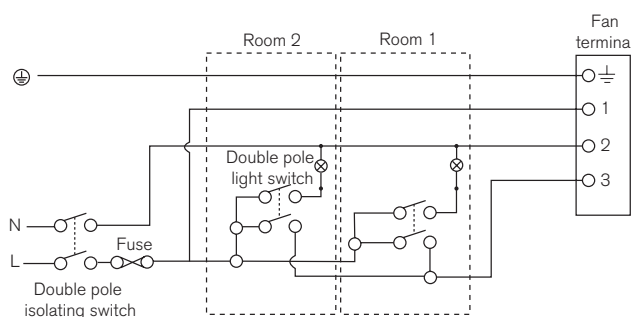

Note:

If no TIMER is fitted or likely to be fitted to P1 or PD fans, omit connection to terminal No.1.

Cable Size:

4 core 1.00mm² max
230V 50Hz

Motor Ratings:

P1 25 Watts
PD 28 Watts

Electrical connector in assembled position

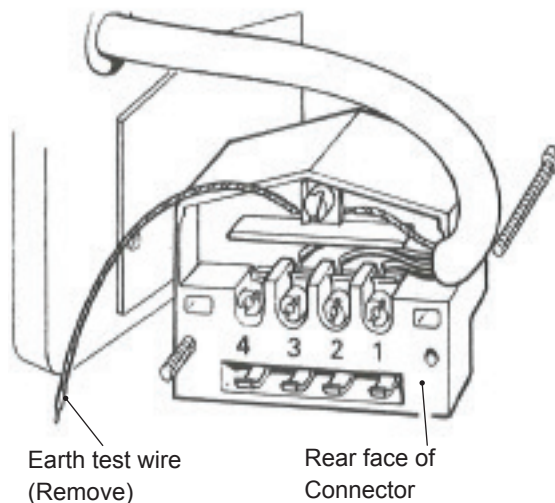
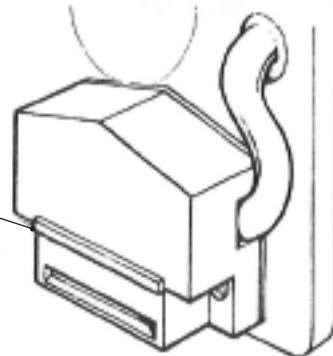

Service Instructions

This unit must periodically be cleaned to free any dust and fluff and must be carried out by a competent person.

The inside of the unit is to be cleaned to avoid build up of talcum powder etc. Handle fan wheel carefully, do not distort blades.

The motor is lubricated for a serviceable life.

Zehnder Group UK Limited
Watchmoor Point, Camberley, Surrey, GU15 3AD

Customer Services: +44 (0) 1276 408404
Technical Services: +44 (0) 1276 408402
Email: info@greenwood.co.uk
Web: www.greenwood.co.uk



P1/PD Installation Instructions

Please read all instructions before commencing installation.

1. Observe appropriate safety precautions if working off steps or ladders.
2. Wear eye protection when breaking out wall or ceiling materials etc.
3. Siting notes:
To avoid short circuiting of air flow, fans should be sited at a high level and as far away as possible from the main source of replacement air. The fan should not be sited where it would be subject to a direct source of heat in excess of 40° C. If installed in a room containing a fuel burning appliance of a non-balance flue design, it is the responsibility of the installer to ensure that sufficient replacement air is provided to prevent products of combustion from being drawn down the flue when the fan is operating and that the air intake is located at least 500mm away from the flue. Exhaust air from the fan must not be allowed to discharge into a flue used for extracting fumes from an appliance other than those powered by electricity. Regulations regarding the discharge of exhaust air must be observed.
4. When installing wall mounted fans, cable run, or switches, ensure that there are no buried cables or pipes in the way. Greenwood Airvac recommends that this fan is mounted 1.8m above floor level.
5. This appliance can be used by children aged from 8 years and above and persons with reduced physical, sensory or mental capabilities or lack of experience and knowledge if they have been given supervision or instruction concerning use of the appliance in a safe way and understand the hazards involved. Children shall not play with the appliance. Cleaning and user maintenance shall not be made by children without supervision.

Installation

Horizontal Duct Mounting

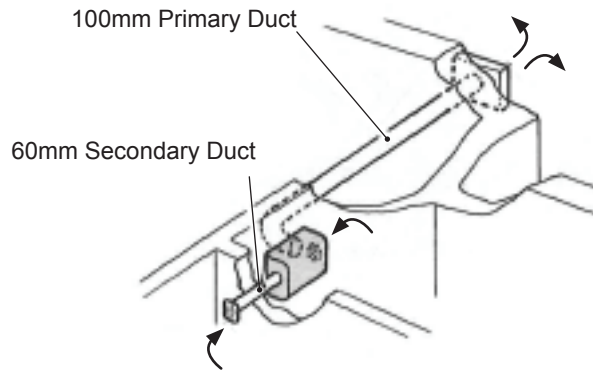

For speed and ease of installation use Greenwood Flexiduct.

1. Cut an opening 100mm diameter through the wall with slight fall to exterior.
2. Remove fan cover.
3. Drill and plug 4 screw holes suitable for No.8 screws.
4. Fit adhesive foam plastic strip around exhaust spigot (not required if flexiduct hose-clip is used).
5. Fit adhesive foam plastic strip around secondary inlet spigot if required.
6. Fit rubber sealing strip around base plate of unit. Ensuring that it has shortest side outward. (P1 only).
7. Fit anti-back-draught shutter into exhaust spigot ensuring hinge is to the top. (P1 only).
8. Fit base plate to wall using No.8 screws.

Note: PD only to fit, motor chassis may be unscrewed and unplugged from the base plate before fixing base plate to the wall.

9. Fit timer if required. (See separate installation instructions).
10. Wire fan as required. (See wiring diagram).
11. If cable knock outs in Terminal Block Cover are removed, ensure that the edges of the knock outs are dressed so that the external cable insulation is not damaged by any sharp edges.
12. Replace cover, ensuring printed circuit tongue locates in the electrical connector and is fully home.

Installation

Vertical Duct Mounting

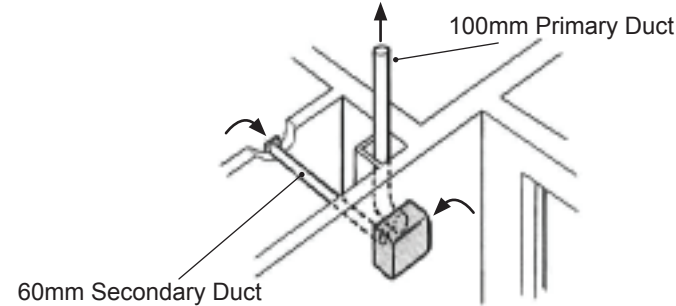

For speed and ease of installation use Greenwood Flexiduct.

1. Cut an opening 100mm diameter through the wall with a set in duct.
2. Remove fan cover.
3. Drill and plug 4 screw fixing holes.
4. Fit adhesive foam plastic strip around exhaust spigot (not required if flexiduct hose-clip is used).
5. Fit adhesive foam plastic strip around secondary inlet spigot if required.
6. Fit rubber sealing strip around base plate of unit. Ensuring that it has shortest side outward. (P1 only).
7. Fit anti-back-draught shutter into exhaust spigot ensuring hinge is to the top. (P1 only).
8. Fit base plate to wall using No.8 screws.

Note: PD only to fit, motor chassis may be unscrewed and unplugged from the base plate before fixing base plate to the wall.

9. Fit timer if required. (See separate installation instructions).
10. Wire fan as required. (See wiring diagram).
11. If cable knock outs in Terminal Block Cover are removed, ensure that the edges of the knock outs are dressed so that the external cable insulation is not damaged by any sharp edges.
12. Replace cover, ensuring printed circuit tongue locates in the electrical connector and is fully home.

Wiring Notes

1. All wiring must be in accordance with prevailing national standards (eg. BS7671 IEE UK Wiring Regulations) and carried out by a qualified electrician.
2. Switch off mains supply before commencing any installation, electrical, cleaning, or servicing work.
3. A double pole isolating switch with a minimum contact gap of 3mm should be used in series with each fan.
4. For single units use a 3 amp fuse. When supplied from a 6 amp lighting circuit no local fuse is required.
5. To wire the unit:
 - a. Remove the fan cover.
 - b. Remove screws securing connector block.
 - c. Remove earth test wire and discard.
 - d. Make all connections on rear of connector block

Note: No mains connections are to be made to the front of the electrical connector at this will by-pass the electrical isolator.

- e. Replace screws securing connector block.
- f. Replace cover, ensuring printed circuit tongue engages in the electrical connector and is fully home.

