

Zehnder ComfoAir 155 WM

The Zehnder ComfoAir 155 WM is a heat recovery unit designed to enable better and easier specification of ventilation in new properties. It contains features such as its automatic true summer by-pass, high heat recovery efficiency and integrated humidity sensor to provide a comfortable, healthy and energy-efficient indoor climate.



ZGRC1 Speed controller



ZGS2 Switch



ZGS1 Switch

Key Features

- Left or right hand configuration through software alone, no mechanical alteration required.
- 100% full and filtered summer bypass.
- Modern, discreet design.
- Easy installation to wall, cupboard or kitchen cupboard.
- Light to handle.
- BMS capability.
- Tool free filter access.
- Volt free contact boost capability.
- CommissionSMART is a commissioning wizard that enable a quick and simple set-up process.
- SummerSMART ensures automatic full by-pass activation providing filtered supply air 365 days a year.
- TimerSMART eliminates nuisance noise and over-ventilation by determining the duration of occupancy and allocating a suitable overrun time.
- HumidiSMART continuously monitors the humidity level within the home and looks for a man-made spike before boosting the unit, irrespective of distance or dilution.
- 100% variable AUX speed for use as away mode, medium speed or purge boost.
- Independently tested sound data.

SAP PCDB Test Results

	SFP (W/l/s)		Efficiency (%)	
	2009	2012	2009	2012
K+1	0.5	0.56	93%	92%
K+2	0.54	0.69	92%	91%
K+3	0.64	0.88	91%	90%
K+4	0.78	1.15	90%	89%
K+5	0.95	1.41	89%	88%
K+6	1.13		89%	
K+7	1.35		88%	

SEC Class



Based on average climate with local demand control

Article Numbers

Description	Product Code
Zehnder ComfoAir 155 WM for wall or cupboard mounting with SMART technology	CA155WM-GB
Controls, two position switch for ComfoAir 155/185 and Centair range	ZGS2
Controls, three position switch for ComfoAir 155/185 and Centair range	ZGS1
Controls, dual speed controller for ComfoAir 155/185 range with operational and service indicators	ZGRC1
Controls, remote air quality sensor	AQR
Controls, remote humidity sensor	HHRW
Controls, remote passive infra-red movement sensor	PIRR
Controls, remote temperature sensor	THR

Article Numbers

Description

Filter for Zehnder ComfoAir 155 WM, ISO Coarse >45% (G3), 2 Pieces
Heat exchanger for Zehnder ComfoAir 155 WM

Product Code

CA155FIL
CA155EX

Technical Specification

Weight	18 Kg
Ducting ø	125 mm
Condensate connection ø	21.5 mm
Filter grade	ISO Coarse >45% (G3)
Materials	Internal PP/EPS External ABS
Supply voltage	230V / single-phase / 50Hz
Maximum power consumption	165 W
Current draw	1.1 amp
Fuse	3 amp
Specific Fan Power	0.5 W/l/s
Heat Recovery Efficiency	93%

Dimensions

Height	644 mm
Width	546 mm
Depth	298 mm

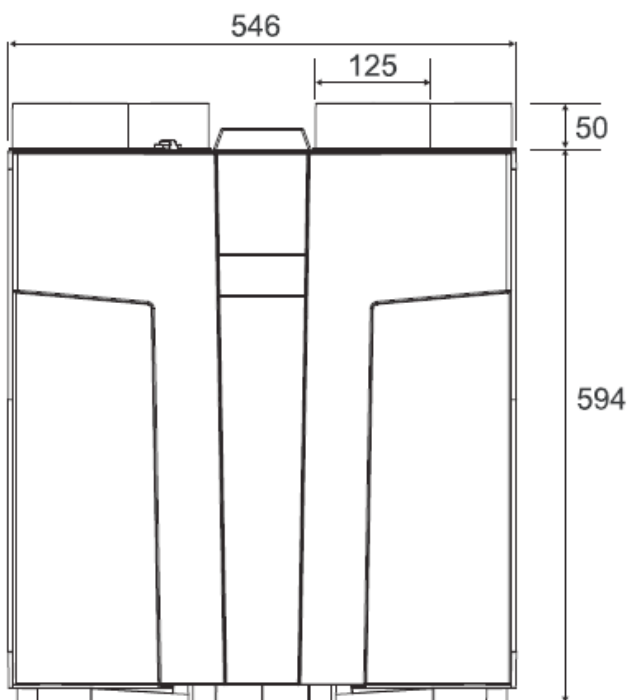

Front View

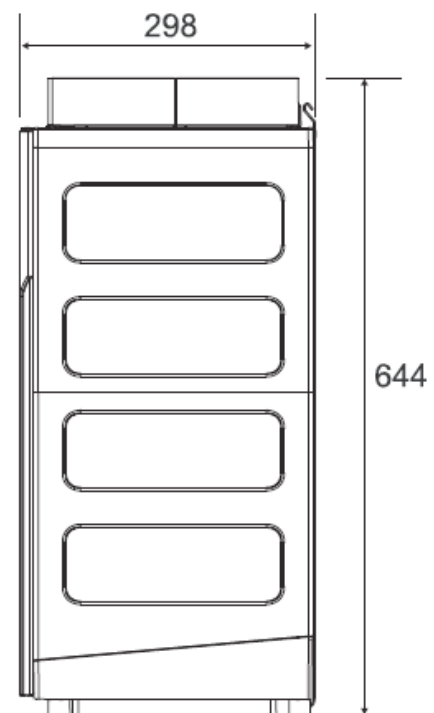

Side View

Pressure Curve

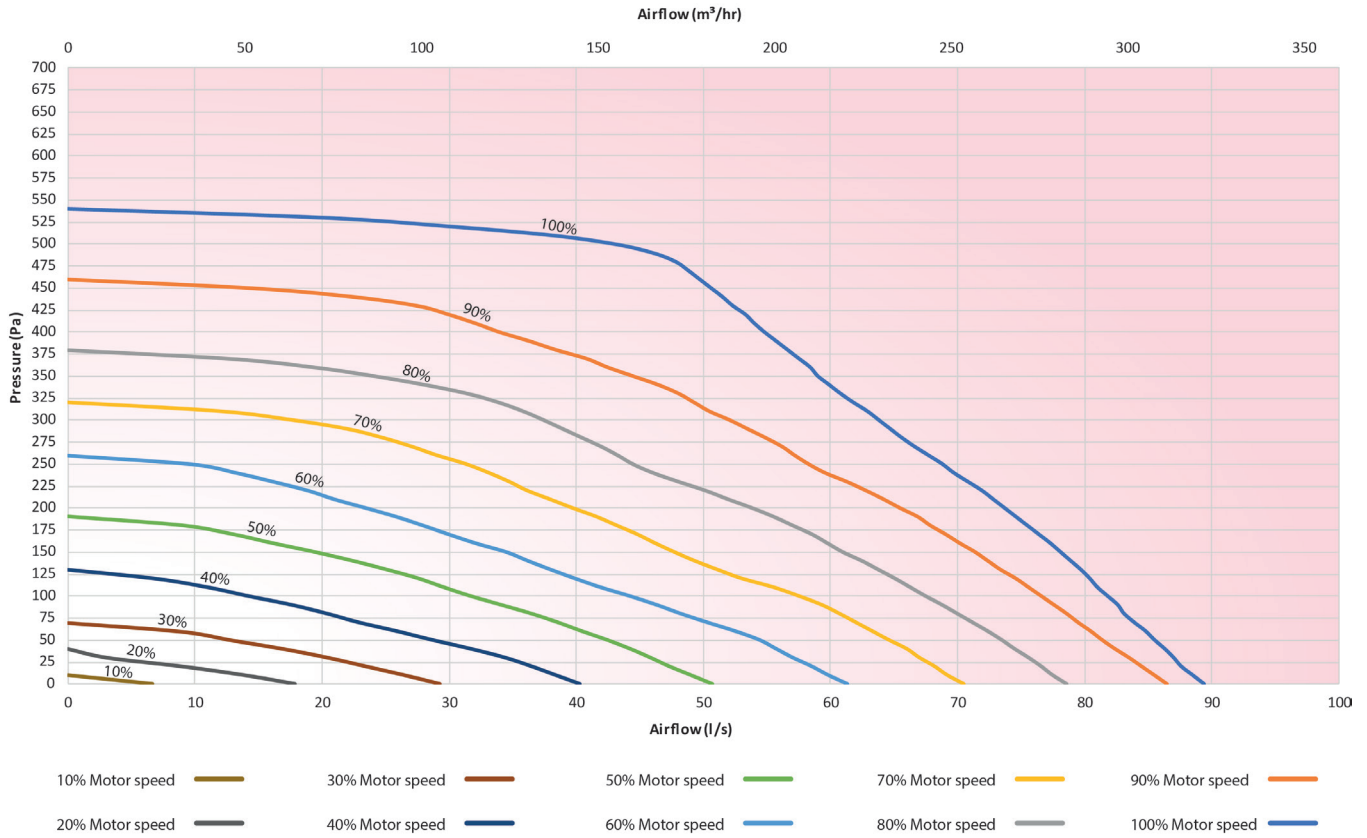

Sound Data

Speed	Test area	Octave Band (Hz) Sound Power Level, dB								Overall LwA, dB	dB(A) @ 3m
		63	125	250	500	1000	2000	4000	8000		
20%	Casing	27.3	26.1	23.9	26.6	20.6	15.4	18.1	23.1	28.2	10.7
	Supply/Exhaust	49.4	42.6	33.8	33.7	26.7	16.4	18.1	23.1	34.5	
	Extract/Intake	49.9	42.5	31.4	26	20	14.5	17.9	23	31.2	
40%	Casing	34	41.1	40.8	43.3	41.4	34.7	28.8	24.6	44.9	27.4
	Supply/Exhaust	63.9	60.8	52.7	53.2	53.6	45.7	37.6	34	56.5	
	Extract/Intake	53.1	50.8	43.7	40	40.1	31.3	22.7	23.3	43.7	
60%	Casing	37.9	47.7	47.6	48.3	46.2	42.7	37.1	31.3	50.6	33.1
	Supply/Exhaust	68.3	66.6	58.9	57.4	58.6	55.3	45.9	44.8	62.4	
	Extract/Intake	54.7	55.7	51	44.8	44.5	38.6	29.1	26.2	49	
80%	Casing	41	50.1	49.4	50.7	47.5	45.4	39.9	34.8	52.7	35.2
	Supply/Exhaust	69.7	70	60.9	60	59.7	58	48.8	48.4	64.6	
	Extract/Intake	56.8	58.4	52.6	47.2	46	40.9	32.1	28.5	51	
100%	Casing	42	55.1	54	55.6	50.5	50.1	44.6	39.9	57	39.5
	Supply/Exhaust	73.1	73.5	65.1	63.9	62.5	61.8	53.6	53.9	68.1	
	Extract/Intake	58.4	61.2	57.6	51.6	48.8	45.2	37.1	34.1	54.9	

Air Direction/Connection

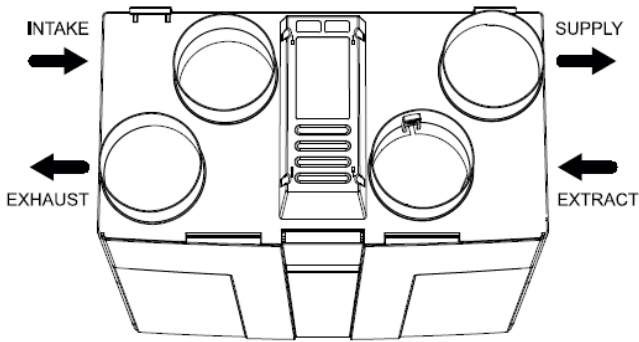

Right Hand (factory setting)

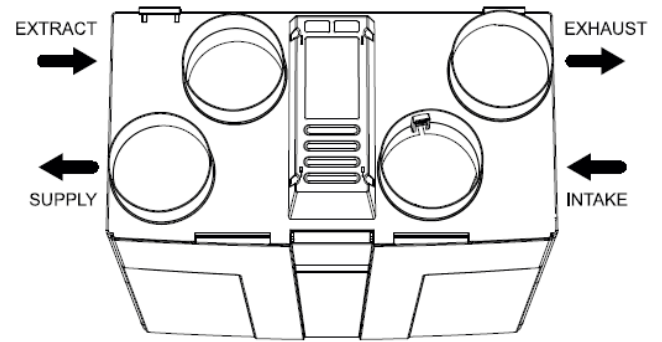

Left Hand

Wiring

Electrical connections should be carried out in accordance to IEE regulations by a qualified electrician. The unit is supplied with a flying lead for connection to the mains supply.

Three speed control via ZGS1 switch

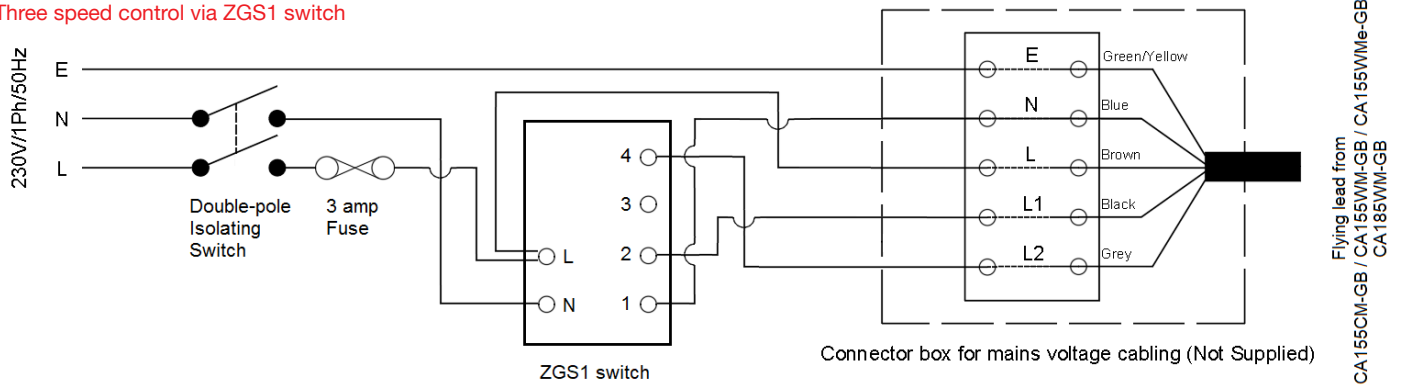

Two speed control via ZGS2 Switch

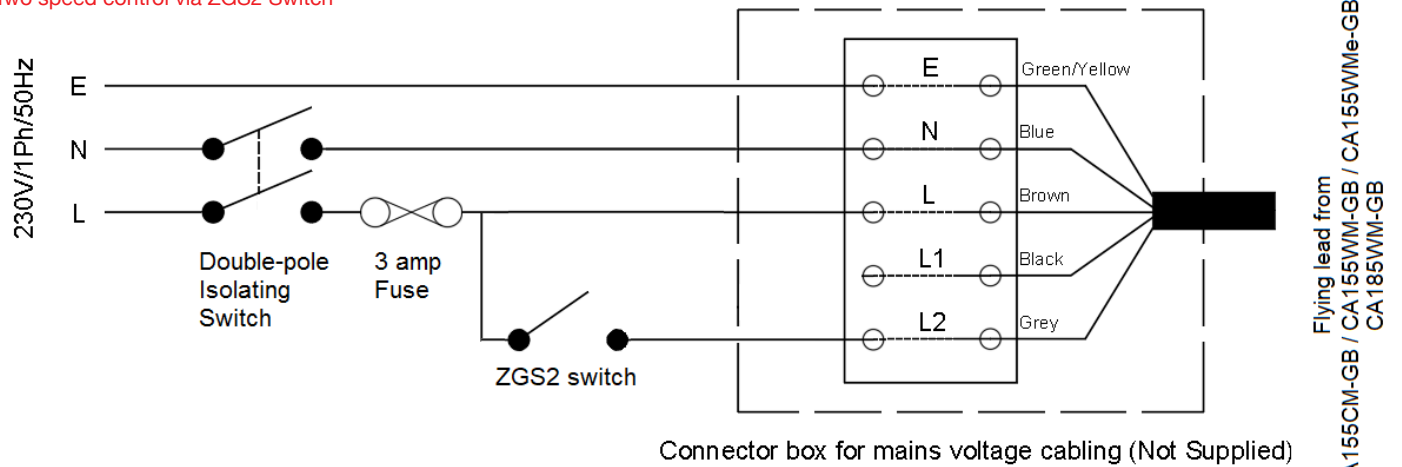

Wiring

Two speed control via light switch

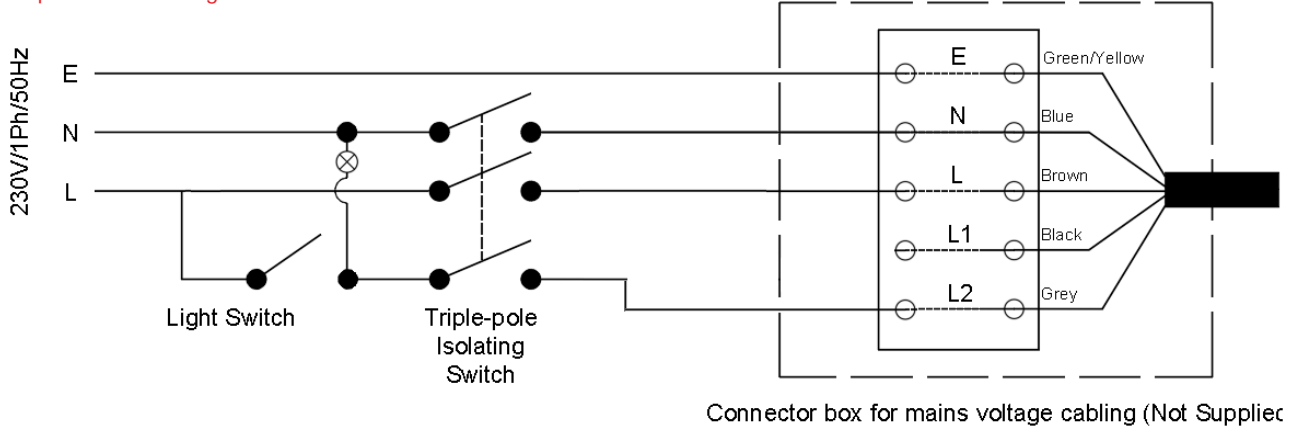

Flying lead from
CA155CM-GB / CA155WM-GB / CA155WMe-GB /
CA185WM-GB

Two speed control via ZGRC1 switch

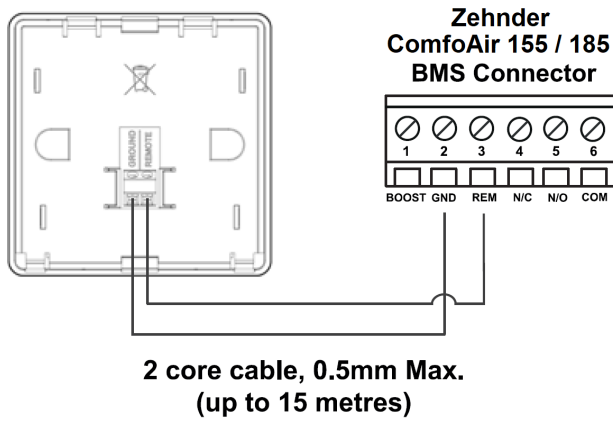

ComfoAir + BMS Connection

ELECTRICAL CONNECTION / TERMINAL DIAGRAM

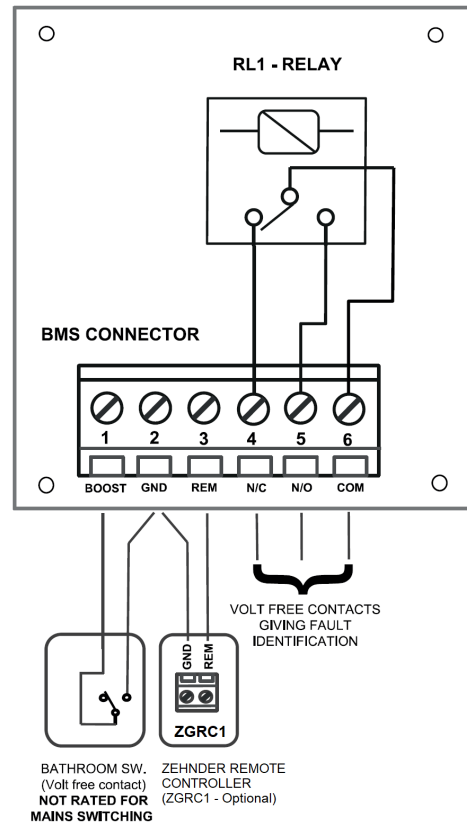

Controls

Intelligent ventilation control for customised year round comfort. Power is nothing without control... Our MEV, MVHR units and extraction fans can be simply and effectively controlled to ensure optimal performance around the clock.

ZGS1



The Zehnder ZGS1 is a three position switch designed to enable the user to manually select the desired ventilation systems flow rate.

Key Benefits

- 3 separate ventilation flow rate options to select in 1 controller

Technical Specification

Mounting options	Recessed
Supply voltage	Mains power - 230V / single-phase / 50Hz

Dimensions (recessed)

Height	84mm
Width	84mm
Depth	22mm

Description

Suitable for MEV and MVHR units:

Description	Product Code
Centair CMEV.4eHT for wall, floor or cupboard mounting with SMART technology	CMEV.4eHT
Zehnder ComfoAir 155 CM for ceiling mounting with SMART technology	CA155CM-GB
Zehnder ComfoAir 155 WM for wall or cupboard mounting with SMART technology	CA155WM-GB
Zehnder ComfoAir 155 WMe for wall or cupboard mounting with SMART technology	CA155WMe-GB
Zehnder ComfoAir 185 WM for wall or cupboard mounting with SMART technology	CA185WM-GB

Dimensions (surface mounted)

Height	84mm
Width	84mm

Article

ZGS1

ZGS2



The Zehnder ZGS2 is a two position switch designed to enable the user to manually select the desired ventilation systems flow rate.

Key Benefits

- 2 separate ventilation flow rate options to select in 1 controller

Technical Specification

Mounting options	Recessed
Supply voltage	Mains power - 230V / single-phase / 50Hz

Dimensions (recessed)

Height	86mm
Width	86mm
Depth	15mm

Description

Suitable for use with MEV and MVHR units:

Description	Product Code
Centair CMEV.4e for wall, floor or cupboard mounting	CMEV.4e
Centair CMEV.4eHT for wall, floor or cupboard mounting with SMART technology	CMEV.4eHT
Zehnder ComfoAir 155 CM for ceiling mounting with SMART technology	CA155CM-GB
Zehnder ComfoAir 155 WM for wall or cupboard mounting with SMART technology	CA155WM-GB
Zehnder ComfoAir 155 WMe for wall or cupboard mounting with SMART technology	CA155WMe-GB
Zehnder ComfoAir 185 WM for wall or cupboard mounting with SMART technology	CA185WM-GB

Article

ZGS2

ZGRC1

The Zehnder ZGRC1 is a two position switch designed to enable the user to manually select the desired ventilation systems flow rate and provide system notifications.



Key Benefits

- 2 separate ventilation flow rate options to select in 1 controller
- Summer bypass indicator
- Frost protection indicator
- Service and Maintenance alert
- Automatic switching back to low speed after a preset time period to avoid the unit accidentally being left in its high speed

Technical Specification

Mounting options	Recessed / Surface
Supply voltage	Low voltage direct from the MVHR units BMS connector
Recommended cable	2 core cable, 0.5mm Max. (up to 15 metres)
RAL colour	9016

Description

Suitable for MVHR units:

Zehnder ComfoAir 155 CM for ceiling mounting with SMART technology	CA155CM-GB
Zehnder ComfoAir 155 WM for wall or cupboard mounting with SMART technology	CA155WM-GB
Zehnder ComfoAir 155 WMe for wall or cupboard mounting with SMART technology	CA155WMe-GB
Zehnder ComfoAir 185 WM for wall or cupboard mounting with SMART technology	CA185WM-GB

Dimensions (recessed)

Height	90mm
Width	90mm
Depth	21mm

Dimensions (surface mounted)

Height	90mm
Width	90mm
Depth	37mm

Product Code

Article

ZGRC1

AQR



The Zehnder AQR remote air quality sensor enables a signal to be sent to the ventilation system to automatically place the unit into a higher flow rate.

Key Benefits

- Set activation level covering a range of pollutants such as hydrogen, CO, methane, ethanol and isobutane
- Adjustable overrun timer between 2-40 minutes
- Can be fitted with locking security straps to prevent tampering
- Suitable for locating where temperatures don't exceed 45°C

Technical Specification

Mounting options	Surface
Supply voltage	Mains power - 230V / single-phase / 50Hz

Dimensions (recessed)

Height	86mm
Width	93mm
Depth	20mm

Dimensions (surface mounted)

Height	86mm
Width	93mm
Depth	37mm

Description

Suitable for use with MEV and MVHR units:

Centair CMEV.4e for wall, floor or cupboard mounting	CMEV.4e
Centair CMEV.4eHT for wall, floor or cupboard mounting with SMART technology	CMEV.4eHT
Zehnder ComfoAir 155 CM for ceiling mounting with SMART technology	CA155CM-GB
Zehnder ComfoAir 155 WM for wall or cupboard mounting with SMART technology	CA155WM-GB
Zehnder ComfoAir 155 WMe for wall or cupboard mounting with SMART technology	CA155WMe-GB
Zehnder ComfoAir 185 WM for wall or cupboard mounting with SMART technology	CA185WM-GB
Zehnder ComfoAir 160	471218950
Zehnder ComfoAir 200, left handed	471226010
Zehnder ComfoAir 200, right handed	471226015
Zehnder ComfoAir 350, left handed	471233400
Zehnder ComfoAir 350, right handed	471233405

Product Code

Article

AQR

HHRW

The Zehnder HHRW remote humidity sensor enables a signal to be sent to the ventilation system to automatically place the unit into a higher flow rate.



Key Benefits

- Set humidity activation between 30-90% relative humidity
- Adjustable overrun timer between 2-40 minutes
- Can be fitted with locking security straps to prevent tampering
- Suitable for locating where temperatures don't exceed 45°C

Technical Specification

Mounting options	Surface
Supply voltage	Mains power - 230V / single-phase / 50Hz

Dimensions (recessed)

Height	86mm
Width	93mm
Depth	20mm

Dimensions (surface mounted)

Height	86mm
Width	93mm
Depth	37mm

Description

Suitable for use with MEV and MVHR units:

Product Code

Article

HHRW

Centair CMEV.4e for wall, floor or cupboard mounting	CMEV.4e
Centair CMEV.4eHT for wall, floor or cupboard mounting with SMART technology	CMEV.4eHT
Zehnder ComfoAir 155 CM for ceiling mounting with SMART technology	CA155CM-GB
Zehnder ComfoAir 155 WM for wall or cupboard mounting with SMART technology	CA155WM-GB
Zehnder ComfoAir 155 WMe for wall or cupboard mounting with SMART technology	CA155WMe-GB
Zehnder ComfoAir 185 WM for wall or cupboard mounting with SMART technology	CA185WM-GB
Zehnder ComfoAir 160	471218950
Zehnder ComfoAir 200, left handed	471226010
Zehnder ComfoAir 200, right handed	471226015
Zehnder ComfoAir 350, left handed	471233400
Zehnder ComfoAir 350, right handed	471233405

PIRR



The Zehnder PIRR remote passive infra-red movement sensor enables a signal to be sent to the ventilation system to automatically place the unit into a higher flow rate.

Key Benefits

- Senses movement upto 7m away
- Adjustable overrun timer between 2-40 minutes
- Can be fitted with locking security straps to prevent tampering
- Suitable for locating where temperatures don't exceed 45°C

Technical Specification

Mounting options	Surface
Supply voltage	Mains power - 230V / single-phase / 50Hz

Dimensions (recessed)

Height	86mm
Width	93mm
Depth	20mm

Dimensions (surface mounted)

Height	86mm
Width	93mm
Depth	37mm

Description

Suitable for use with MEV and MVHR units:

Product Code

Article

PIRR

Centair CMEV.4e for wall, floor or cupboard mounting	CMEV.4e
Centair CMEV.4eHT for wall, floor or cupboard mounting with SMART technology	CMEV.4eHT
Zehnder ComfoAir 155 CM for ceiling mounting with SMART technology	CA155CM-GB
Zehnder ComfoAir 155 WM for wall or cupboard mounting with SMART technology	CA155WM-GB
Zehnder ComfoAir 155 WMe for wall or cupboard mounting with SMART technology	CA155WMe-GB
Zehnder ComfoAir 185 WM for wall or cupboard mounting with SMART technology	CA185WM-GB
Zehnder ComfoAir 160	471218950
Zehnder ComfoAir 200, left handed	471226010
Zehnder ComfoAir 200, right handed	471226015
Zehnder ComfoAir 350, left handed	471233400
Zehnder ComfoAir 350, right handed	471233405

THR

The Zehnder THR remote temperature sensor enables a signal to be sent to the ventilation system to automatically place the unit into a higher flow rate.



Key Benefits

- Set temperature activation between 5-35°C
- Fixed 2 minute overrun timer
- Can be fitted with locking security straps to prevent tampering
- Suitable for locating where temperatures don't exceed 45°C

Technical Specification

Mounting options	Surface
Supply voltage	Mains power - 230V / single-phase / 50Hz

Dimensions (recessed)

Height	86mm
Width	93mm
Depth	20mm

Dimensions (surface mounted)

Height	86mm
Width	93mm
Depth	37mm

Description

Suitable for use with MEV and MVHR units:

Product Code

Article

THR

Centair CMEV.4e for wall, floor or cupboard mounting	CMEV.4e
Centair CMEV.4eHT for wall, floor or cupboard mounting with SMART technology	CMEV.4eHT
Zehnder ComfoAir 155 CM for ceiling mounting with SMART technology	CA155CM-GB
Zehnder ComfoAir 155 WM for wall or cupboard mounting with SMART technology	CA155WM-GB
Zehnder ComfoAir 155 WMe for wall or cupboard mounting with SMART technology	CA155WMe-GB
Zehnder ComfoAir 185 WM for wall or cupboard mounting with SMART technology	CA185WM-GB
Zehnder ComfoAir 160	471218950
Zehnder ComfoAir 200, left handed	471226010
Zehnder ComfoAir 200, right handed	471226015
Zehnder ComfoAir 350, left handed	471233400
Zehnder ComfoAir 350, right handed	471233405

Consultant specification

Specification

The unit shall consist of a body manufactured in recyclable ABS. The unit shall be fully insulated with EPS to maintain excellent thermal characteristics. It shall have EC low energy motors with sealed for life bearings. The fan shall have a forward curved centrifugal impeller. The heat exchanger shall be a multi-plate, counter flow design constructed from Polystyrene with laser welded joints and shall retain up to 93% of the temperature differential of outgoing air.

The unit shall contain filters manufactured from synthetic material which has been tested to a minimum of ISO Coarse >45% (G3) standard. The filters shall be pleated to reduce the pressure drop whilst increasing the time between maintenance requirement. The unit shall have 125mm duct connections and be suitable for vertical wall mounting with the ability to allow left or right hand configuration through the unit's software alone – no mechanical reconfiguration shall be required. The unit shall be compatible with air conditioning systems as condensate can be taken from both sides of the product simultaneously.

The unit shall have 100% full summer by-pass and provide filtered supply air 365 days of the year, even under bypass conditions. The unit shall contain a temperature sensor for each air stream to ensure correct and logical operation of the bypass damper by evaluating differential as well as absolute temperature to maximise the opportunity for free cooling.

The unit shall be constructed to have a removable cover to allow full maintenance access.

The unit shall conform to LVD and EMC standards and be CE Marked in addition to having an EU compliant energy rating label (SEC) with a minimum grade of A. The unit shall be manufactured by Zehnder.

Operation

The supply and extract unit shall be a ComfoAir manufactured by Zehnder and shall be suitable to mount on a wall or in a cupboard in accordance with the specification.

The fresh filtered air from outside shall be supplied to each of the habitable rooms and pre-heated by the warm extract air from the wet areas, such as kitchen or bathroom, via the plastic counter flow heat exchanger. The unit shall vary its speed of the EC motors automatically when it receives a signal from one of the inbuilt sensors or via external switches.

The unit shall have the ability to adjust and commission the supply and extract motors independently via the front mounted in-built LCD interface. The motors shall both offer 100% variable speed control.

Controls

All ComfoAir 155/185 units shall contain the following functions within the unit pre-wired and factory fitted by the manufacturer:

- 100% variable supply and extract motor control
- Variable low and high speed flow rate set point
- BMS compatibility offering speed control and status indication
- Switched live input
- Volt free contact
- Automatic filtered summer bypass with timed manual override option
- Heat exchanger frost protection
- Commissioning wizard to enable commissioning of the unit in just 8 simple steps
- Integral service, fault and operation indicators
- Control panel PIN protection
- Tool free filter access
- Runtime counter
- Humidity sensors to operate the unit in response to humidity spikes above natural background humidity levels as opposed to a single threshold humidity point to activate the high set point
- Variable overrun timer relative to high speed activation period
- 100% variable 3rd "AUX" speed for use as away mode, medium speed or purge boost activated via switched live input

zehnder
always the
best climate