



## American Flyer Bikes

E-Wave 2.0 Display  
User Manual



American Flyer Bikes  
640 N. Tustin, Suite 100  
Santa Ana, CA 92705

Phone: 949-791-8099  
Sales: [Sales@americanflyerbikes.com](mailto:Sales@americanflyerbikes.com)  
Support/Warranty: [warranty@americanflyerbikes.com](mailto:warranty@americanflyerbikes.com)

# TABLE OF CONTENTS

<b>ABOUT THE USER MANUAL</b> .....	3
<b>PHYSICAL DIMENSION</b> .....	3
MAIN MATERIAL AND COLOR .....	3
<b>BUTTON DEFINITION</b> .....	4
<b>FUNCTIONAL OVERVIEW</b> .....	4
FULL DISPLAY AREA .....	5
NORMAL DISPLAY AREA.....	5
<b>NORMAL OPERATION</b> .....	5
1、POWER ON/OFF .....	5
2、CURRENT DISPLAY .....	6
3、INSTANT SPEED.....	6
4、KILOMETER MILE SELECTION .....	6
5、BACKLIGHT .....	6
6、6KM/H IMPLEMENTATION .....	6
7、POWER-ASSISTED GEAR .....	7
8、ACCELERATOR .....	7
12、BATTERY DISPLAY .....	13
13、LINE ORDER DEFINITION .....	13
14、10 MINUTES OF AUTOMATIC SLEEP.....	13
<b>INSTALLATION NOTES</b> .....	14
<b>FREQUENTLY ASKED QUESTIONS AND ANSWERS</b> .....	14
<b>QUALITY COMMITMENT AND WARRANTY COVERAGE</b> .....	15
WARRANTY INFORMATION : .....	15
NON-WARRANTY CLAUSE : .....	15
<b>ERROR CODE DEFINITION TABLE</b> .....	

## About the user manual

Dear users, in order to better operate your electric bicycle, please read the instructions of the LWDC3T instrument carefully before use. We will tell you every step of the instrument in the most concise language, from hardware installation and setup to normal use of the instrument. It also helps you solve possible confusions and obstacles.

## physical dimension





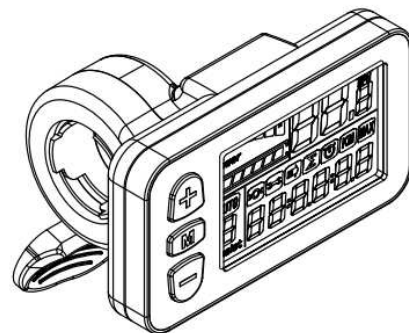
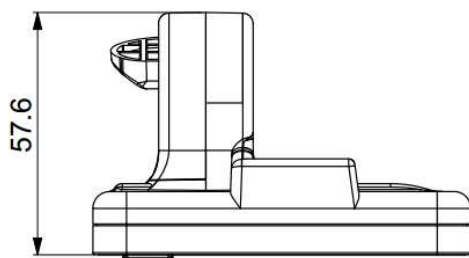
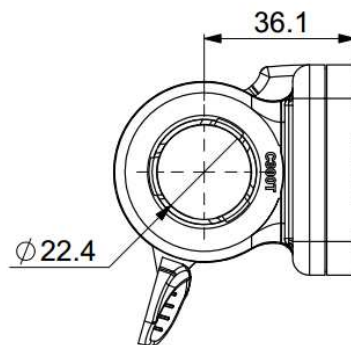
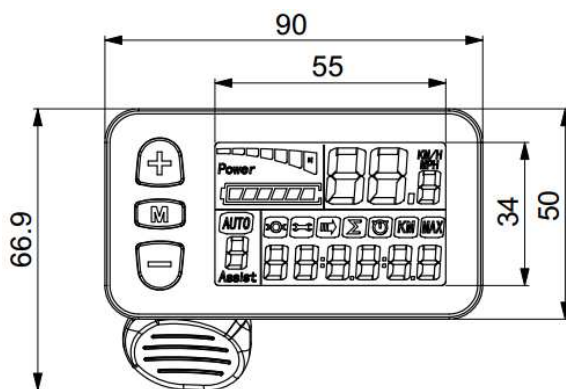

### Main material and color

The LWDC3T is made of black ABS material and the bracket is made of nylon. The material of the outer casing allows normal use at temperatures between  $-20\text{ }^{\circ}\text{C}$  and  $60\text{ }^{\circ}\text{C}$  and guarantees good mechanical properties.

Dimensions (unit : mm)



## Button definition

The instrument is equipped with 3 buttons, including 、 and 。 “” Mode/open key , “” Add key , “” Reduce key 。

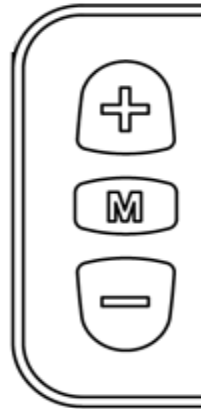

## Functional Overview

The LWDC3T gives you a variety of features and displays to meet your cycling needs.

The contents displayed by LWDC3T are:

1. Switch
2. Current display
3. Instant speed
4. Kilometer mile selection
5. Backlight
6. 6KM/H walking
7. Power-assisted gear
8. Accelerator
9. Error code display
10. Setup operation
11. Mileage display
12. Battery display
13. Line order definition
14. 10 minutes of automatic sleep

## Full display area

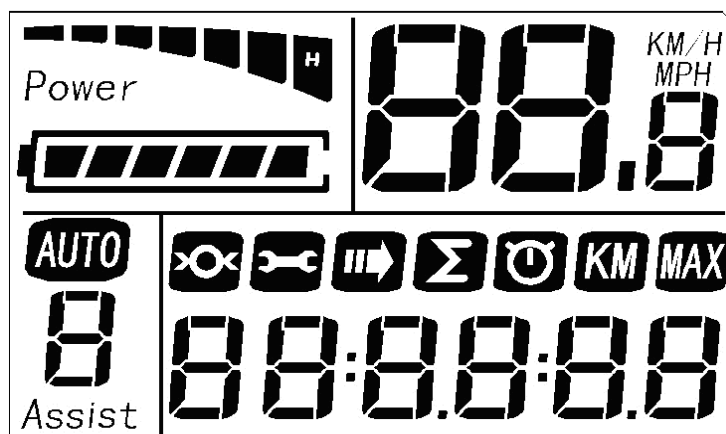

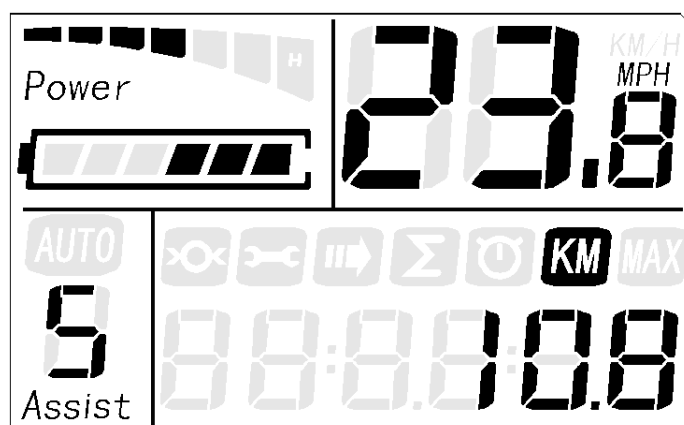

## Normal display area

When the meter is turned on, the current, power, instant speed, total mileage, and power assist position are preset. Press  to switch display information.



## Normal operation

### 1、Power on/off

After pressing the  button, the meter starts to work and provides the controller analog circuit working power. In the power on state, long press the  button for 2 seconds to power off the system.

In the off state, the meter no longer uses the battery's power supply, and the meter's leakage current is less than 2 $\mu$ A.

※ **If the electric bicycle is not used for more than 10 minutes, the meter will automatically shut down.**

## 2、Current display

Indicates the current controller discharge current, each grid is 2A, greater than 12A display 6 grids.



## 3、Instant speed



The meter shows the current riding speed of the electric vehicle. The display is as follows :



## 4、Kilometer mile selection

Choose kilometers or miles, and the speed and mileage will correspond to the corresponding selection.

## 5、Backlight

With the meter on, press  for 1.5s to turn on the backlight, then press  for 1.5s to turn off the backlight.



## 6、6KM/H implementation

Press and hold the  button for 2 seconds to start the 6KM/H implementation function, and the function is automatically released after the hand is loosened.

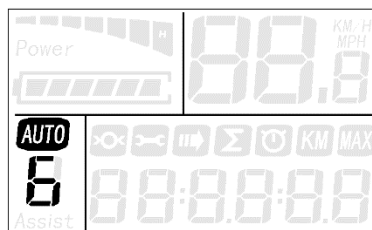
The Auto 6 icon lights up while in the walking state. The display is as follows :



## 7、Power-assisted gear

Touch the  or  button to switch the power assist position of the electric vehicle and change the output power of the motor.

The default output power range of the meter is 0-5.

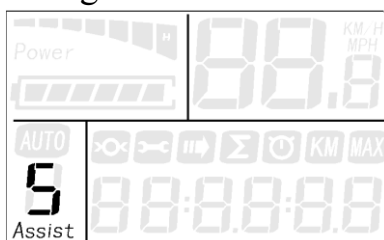

## 8、Accelerator

Rotating the accelerator can change the motor output power (output power from small to large).

※Since it will self-protect detection when it is turned on, there is no output in 1.5s.





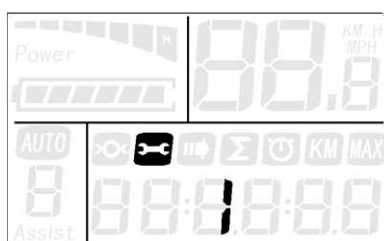

## 9、Error code display

When the system fails, the Error icon and the error code flash together at a frequency of 1 Hz. Different fault codes indicate different fault information. The error code is defined on the last page of this manual.





❖ Exit the fault display interface only when the fault is eliminated.

## 10 · Setup operation

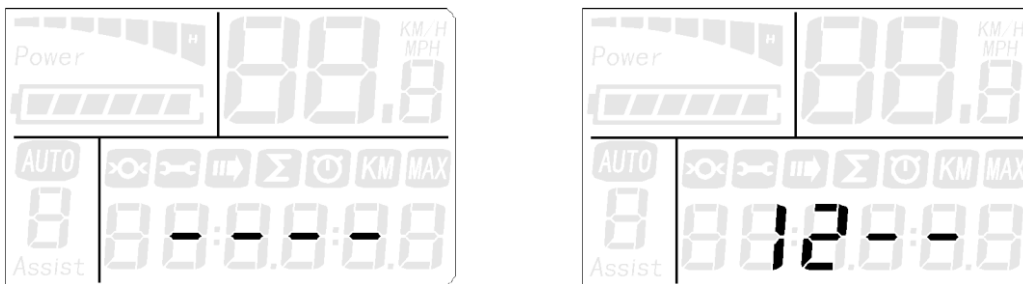

Press and hold the  and  buttons for two seconds at the same time to enter the setting interface. Enter the password before entering, press the  button to switch the digits, touch the  button to select the number, and finally press the  button to confirm. If the input is correct, enter the setting interface. Otherwise, re-enter . Press and hold the  and  keys simultaneously to jump out of the password interface.





In the settings interface, press the  key to switch the setting parameters, long press the  and  keys to exit and save the settings.

### 10.1 Single mileage, riding time clear

Tap the  button to clear the single mileage and riding time.

❖ Press and hold the  and  for 2 seconds in the main screen to clear the single mileage, riding time, and maximum speed.

❖ The maximum speed is automatically cleared after shutdown.

❖ Press and hold the  and  for 10 seconds in the main screen to clear the total mileage, single mileage, riding time, and maximum speed.

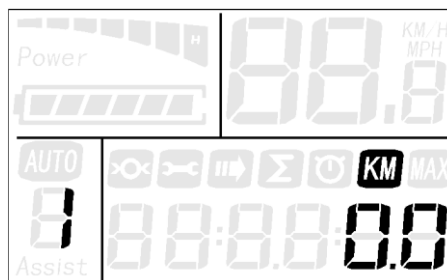



## 11、Mileage display



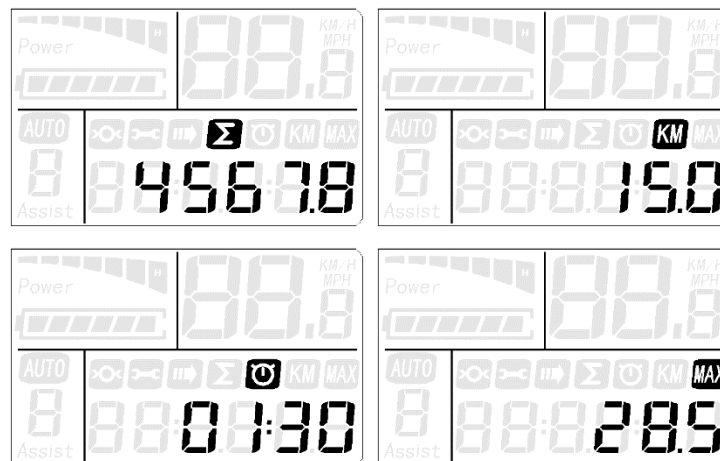





In the normal display mode, touch the  button to select the display total mileage, single mileage, riding time, maximum speed and loop display.



※  Turn on the automatic loop display.

## 12、Battery display

There are six grids in the battery frame. When the battery is fully charged, the six grids are all bright. When the battery is low, the last grid will flash. This indicates that the battery is already low and needs to be charged immediately.

Battery display	Percentage	Remarks
	100%~90%	
	90%~80%	
	80%~60%	
	60%~40%	Suggest charging or replacing the battery.
	40%~20%	Must to charge or replace the battery.
	20%~10%	Must to charge or replace the battery.
 flashing	10%↓	Stop Motor action and show  1

## 14、10 minutes of automatic sleep

When the electric bicycle does not operate for more than 10 minutes, the system will automatically sleep.

## Installation Notes

Place the metal clamp into the clamp placement area at the lower end of the meter and lock it slightly with the M4\*14 socket head cap screw. It is recommended that the screw locking torque is 5kgfcm (maximum 7kgfcm). Place the instrument in the appropriate position on the handlebar, adjust the proper angle of view, and tighten the screw. When the electric bicycle is powered off, the connector of the meter can be inserted into the connector corresponding to the controller to complete the installation.

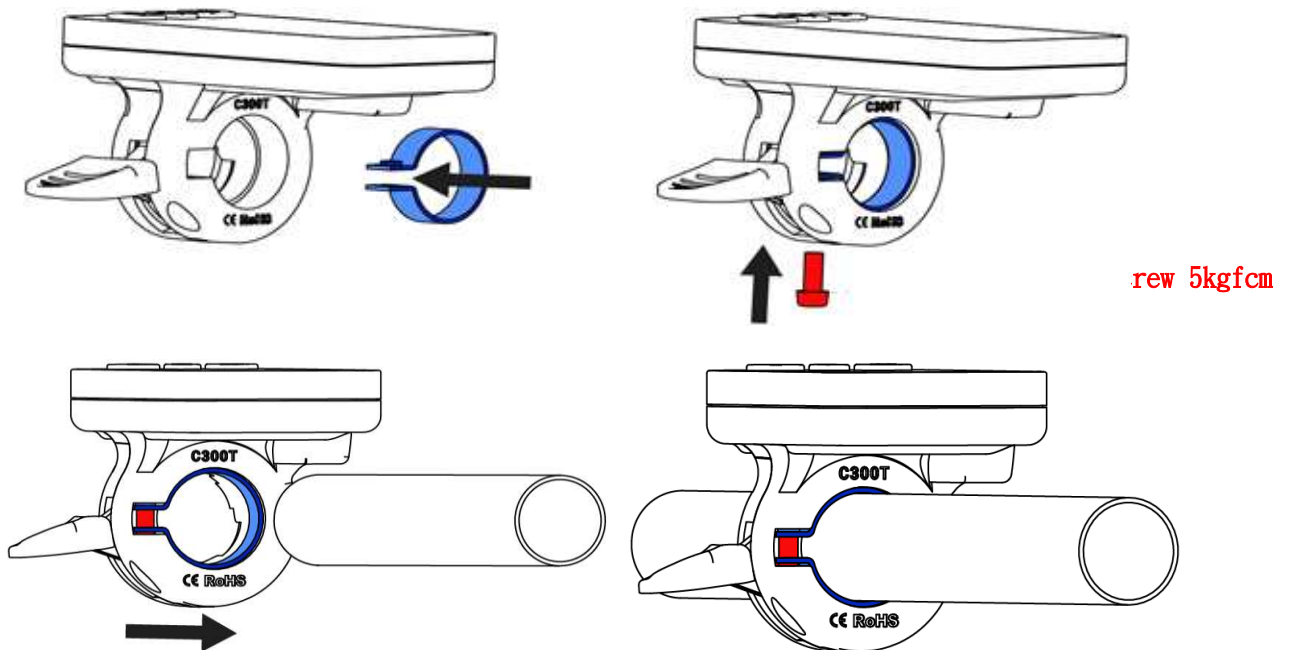

## Frequently asked questions and answers

- Q: Why can't I boot?
- A: Check that the instrument connector is securely connected to the connector of the controller.
- Q: What should I do if the meter displays the fault code?
- A: First find out the corresponding problem according to the displayed error code. If you can't solve it yourself, you should immediately go to the electric vehicle maintenance point for repair.

## **Quality commitment and warranty coverage**

### **Warranty information :**

1. In the case of normal use, due to the quality problems caused by the product itself, the company will be responsible for giving a limited warranty during the warranty period.
2. The warranty period of the product begins within 18 months from the user's purchase of the company's instrument.

### **Non-warranty clause :**

The following conditions are not covered by the warranty :

- 1、 Unauthorized disassembly and modification.
- 2、 Failure or damage caused by misuse or incorrect installation test by the user or third-party manufacturer.
- 3、 After the instrument is shipped, the casing is scratched or the casing is damaged.
- 4、 The instrument line is scratched or broken.
- 5、 Failure or damage caused by natural disasters (such as fires, earthquakes, lightning strikes, etc.).
- 6、 The product is out of warranty.

## Error code definition table

Instrument error display corresponding fault definition :

Error code	Definition	Solution
0	Trouble free	
1	Lithium battery voltage 48V system : <b>42V</b> under 36V system : <b>32V</b> under 24V system : <b>21V</b> under	Check the power resource ; charge or replace the battery
2	Brake stuck or shorted (power on detection)	Check the brake or unplug the brake wire
3	Accelerator stuck or shorted (power on detection)	Check the throttle ; accelerator return the origin
4	LWABS-03(PAS) no signal or phase anomaly	Check the distance between sensor and disc (4mm under) , or disconnect (※1)
	LWP24L(PAS) no signal	Check the sensor doesn't embed in BB groove , or disconnect(※1、※2)
5	Motor overload , reduce motor output	Reboot Restore the maximum output of the motor (prevent the motor over heat)
6	Controller temperature exceeds <b>70°C</b>	power off then wait until the temperature decrease back to normal
7	Motor Hall is abnormal	Check motor line Is it loose or broken
8	Torque sensor signal is abnormal	Re-adjust the torque sensor
9	Motor overcurrent	Reboot
14	Wheel diameter Sensor abnormal	Check this sensor or Induction magnet
15	Lithium battery voltage 48V system : <b>60V</b> above 36V system : <b>44V</b> above 24V system : <b>31V</b> above	Check the power resource ; replace the battery
17	Abnormal communication	Reboot
99	LCD did not receive the correct signal for 5 seconds	Please reconnect the LCD signal line; Still communication is abnormal, please replace the signal line, LCD meter, controller in sequence.

※1. Error code A04 : Pedal Sensor detection (With the Assistance Level on 0 within 30 seconds & Error Code 4 appears when power on):

Pedal Forward, you should see the Sensor LED Flash. If not, it needs to be replaced.

A04 will automatically disappear after 30 seconds of power on or when the segment is not 0.

※2. Stepping on the pedal forward, LED which back of the LWP24L (PAS) outlet will flash, indicating that the signal is correct;

If the LED of LWP24L (PAS) doesn't work, the LWP24L (PAS) body must be replaced.

※3. When power on and the LWDC3T screen lights up over 5 sec, this error indicates that the communication is abnormal. Replace the signal wire, LWDC3T, controller in order.