



# ADAPTOR PLATE

N.T.S.

## TOP VIEW

13-3/4"

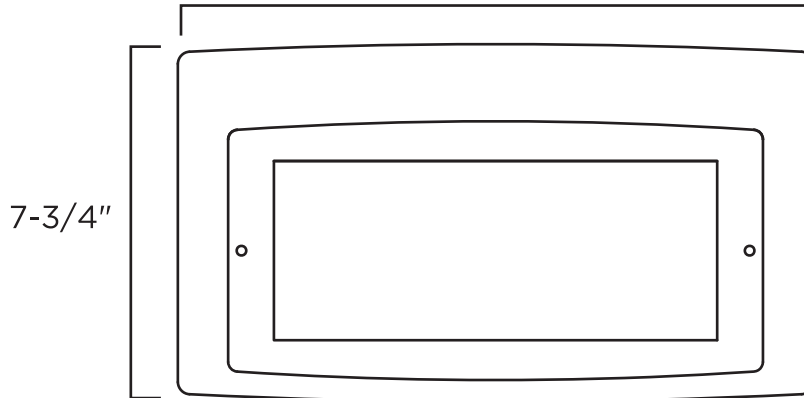

## BACK VIEW

11"

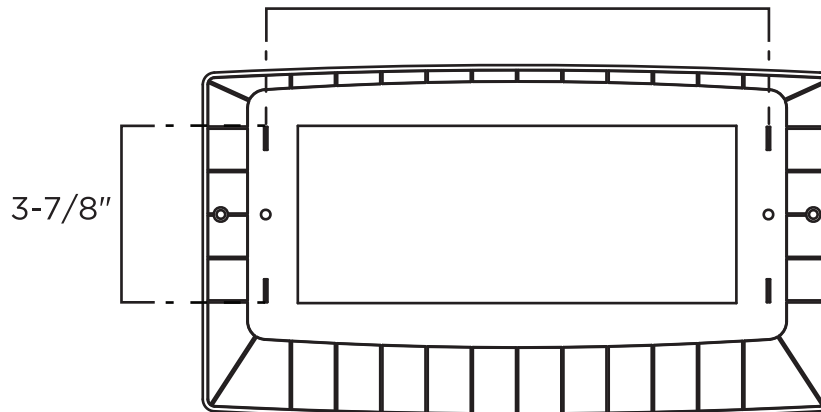

## SIDE VIEW

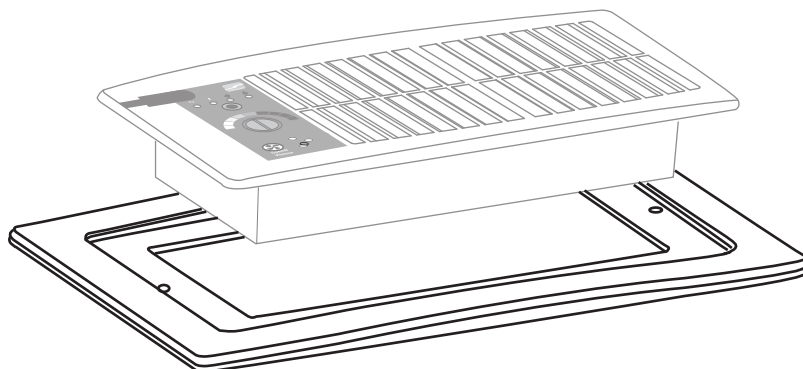
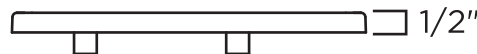

**MODEL: HC5PL1-W & HC5PL1-B**

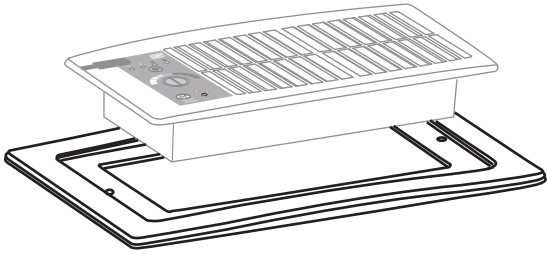

Model #'s: HC5PL1-W & HC5PL1-B  
Fits 4"x12", 6"x10" & 6"x12" wall/floor registers  
1 Year Limited Warranty  
Made in USA  
Primary UOM: EA  
Shipping Multiple: 6  
Available in pearl white (HC5PL1-W) & brown (HC5PL1-B)

#### PERFORMANCE

Used with Suncourt's Flush Fit™ Register Booster™

#### HAZARDOUS MATERIAL INFO:

Not Applicable

#### CUSTOMS TARIFF CLASSIFICATION:

HS Code	Country of Origin	NAFTA Preference Criterion	NAFTA Producer Index
8414901000	USA	C	Y

#### PACKAGING METRICS:

	UPC / SCC	WIDTH (in)	HEIGHT (in)	DEPTH (in)	WEIGHT (lbs)
Unit (1qty):	066028000286	13.75	1.00	7.75	0.50
Master Case (6qty):	40066028000284	14.25	5.25	8.25	3.00

## MODEL: HC5PL-W & HC5PL-B