



N.T.S.

**BOOSTS AIRFLOW TO ROOMS  
THAT ARE TOO HOT OR TOO COLD**

TOP VIEW

11-5/8"

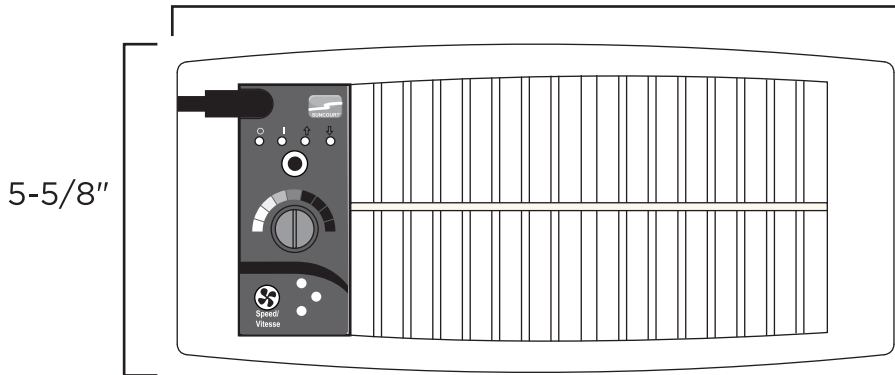

BACK VIEW

11-1/32"

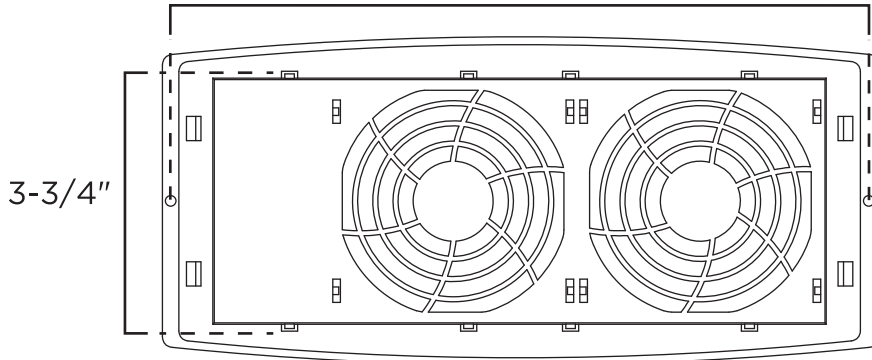

SIDE VIEW

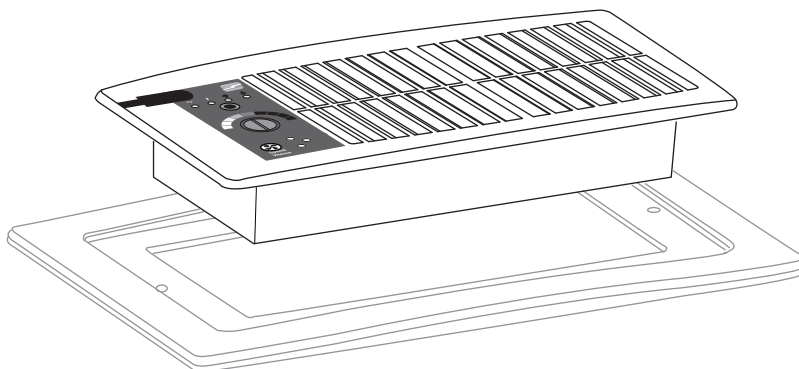
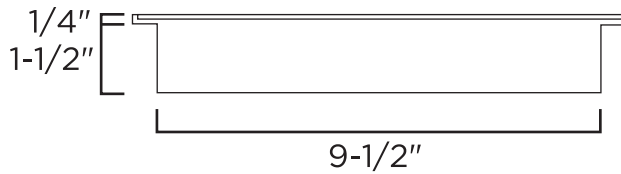

HC5PL1  
ADAPTOR PLATE  
SOLD SEPARATELY

**MODEL: HC500-W & HC500-B**

SUNCOURT INC. | P.O. Box 40 | Durant, IA 52747-0040 | 1.800.999.FANS (3267) | [suncourt.com](http://suncourt.com)

HC500-SS-DS-1220

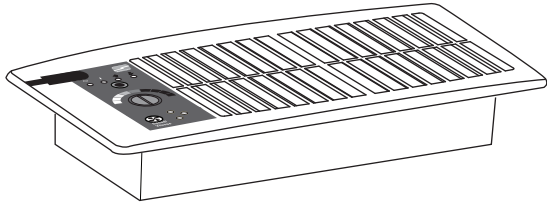

**Model #'s: HC500-W & HC500-B**  
**Fits in 4"x10" floor or wall registers**  
**Adaptor Plate available for larger registers:  
 4"x12", 6"x10" & 6"x12"**  
**1 Year Limited Warranty**  
**Assembled in USA**  
**Primary UOM: EA**  
**Shipping Multiple: 12**  
**Available in white (HC500-W) &  
 brown (HC500-B)**

Model	Unit Weight	Unit Size	Volts	CFM	Running Watts	DBA	Cord Length
HC500-W / HC500-B	1.45 lbs.	11-5/8" x 5-5/8"	12Vdc 500 mA	Up to 132	Up to 3.9	Up to 53	6'

**HAZARDOUS MATERIAL INFO:**

Not Applicable

**CUSTOMS TARIFF CLASSIFICATION:**

HS Code	Country of Origin	NAFTA Preference Criterion	NAFTA Producer Index
8414519090	USA	B	Y

**PACKAGING METRICS:**

	UPC / SCC	WIDTH (in)	HEIGHT (in)	DEPTH (in)	WEIGHT (lbs)
Unit (1qty):	066028000224	13.75	2.25	6.00	1.50
Master Case (12qty):	40066028000222	13.00	14	14.50	19.50

**MODEL: HC500-W & HC500-B**