

TOP VIEW

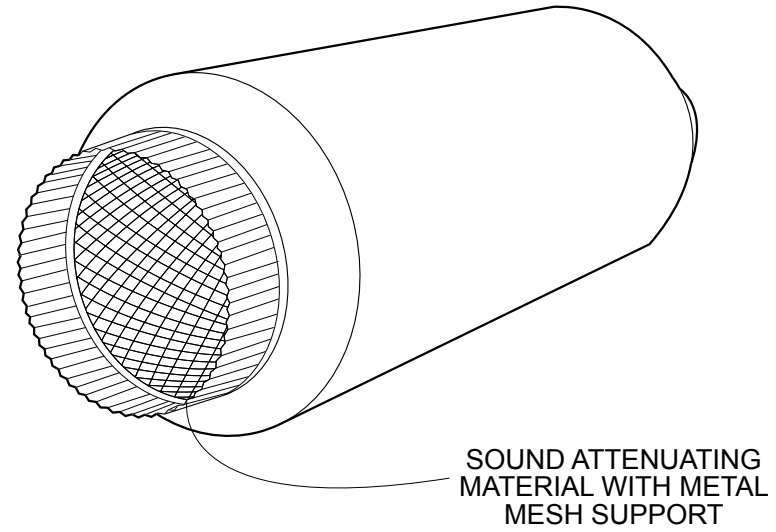

SOUND ATTENUATING MATERIAL WITH METAL MESH SUPPORT

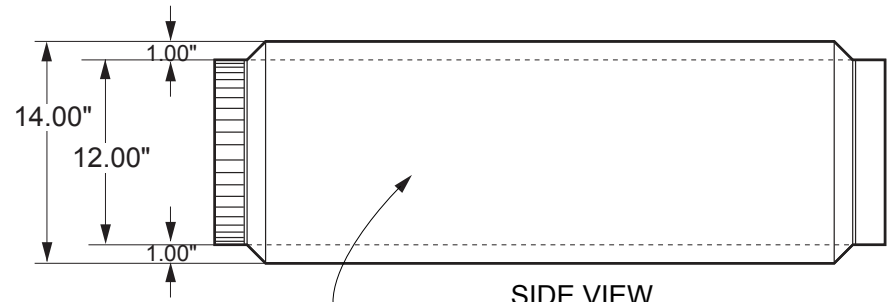

SIDE VIEW

26 GAUGE GALVANIZED STEEL

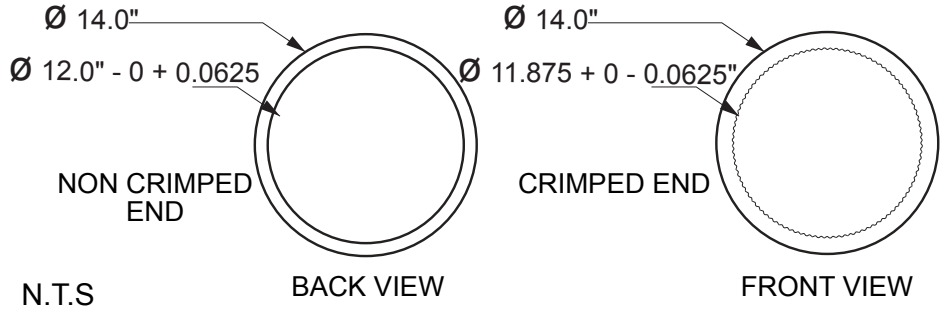

NON CRIMPED END

CRIMPED END

BACK VIEW

FRONT VIEW

N.T.S



DUCTMUFFLER™ IN-LINE NOISE MUFFLER™

MODEL DM112

The DuctMuffler™ In-Line Noise Muffler™ reduces noise heard through registers from adjacent rooms or noisy neighbors.

BUILDING CODE COMPLIANT • MEETS NFPA STANDARDS 90A & 90B
 UL® LISTED • CLASS I AIR DUCT • DUCT DIAMETER: 8"
 UNIT WEIGHT: 15.05 LBS. • ONE YEAR LIMITED WARRANTY
 SOUND REDUCTION: AT 250 Hz: 8.8 dBA
 AT 500 Hz: 16.5 dBA
 AT 1000Hz: 21.8 dBA

SUNCOURT INC.
 P.O. Box 40
 Durant, IA 52747-0040
 1.800.999.FANS (3267)
 www.suncourt.com

PRODUCT DATA SHEET

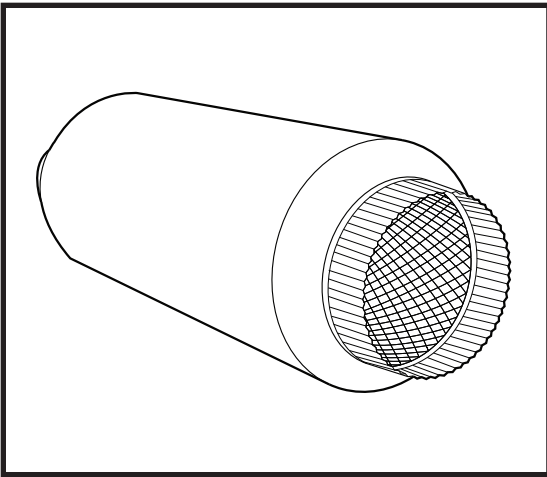

Model: DM112
12" DuctMuffler™ In-Line Noise Muffler™
UL® Listed Acoustic Liner
1 Year Limited Warranty
12" Diameter
Made In USA
Primary UOM: EA
Shipping Multiple: 1

Performance

The DuctMuffler™ In-Line Noise Muffler™ reduces noise heard through registers from adjacent rooms or noisy neighbors.

Hazardous Material Info

Not Applicable

Customs Tariff Classification

HS Code	Country of Origin	NAFTA Preference Criterion	NAFTA Producer Index
7307910000	USA	B	Y

Packaging Metrics

	UPC/SCC	Width (in)	Height (in)	Depth (in)	Weight (lbs)
Unit	066028001122	39.50	16.50	16.50	21.00
Master Case	40066028001120	39.50	16.50	16.50	21.00