



- Length Without Main Blades: 1383mm
- Overall Height: 351mm
- Width: 217mm
- Main Gear: 106T Mod 1
- Pinion Gear: 11T (10-13T Optional)
- Motor Shaft Diameter: 6mm (Length 20-55mm)
- Main Gear Ratio: 9.636 (10.6 - 8.38 Optional)
- Front Tail Pulley: 100T
- Rear Tail Pulley: 21T (20T Optional)

- Tail Ratio: 4.767 (5.0 Optional)
- Frame Weight: 2060g
- Main Shaft Diameter: 15mm
- Feathering Shaft Diameter: 10mm
- Tail Boom Diameter: 32mm
- Tail Belt Width: 8mm
- Main Gear Thickness: 18mm
- Battery Compartment Size: 380mm\*68mm\*70mm

*If you do not observe these instructions, you may be held liable for injury or damage.*

*Operate the helicopter in open areas with no people nearby. Do NOT operate the helicopter in these situations or areas:*

*In places where children gather or people pass through  
In residential areas and parks  
Indoors and in limited space  
Extremely windy weather or when there is rain, snow, fog or other precipitation*

*When operating and tuning/adjusting your model, keep the following in mind:*

*ALWAYS check radio control system for proper operation before operating the model.  
ALWAYS check radio control system power levels before operating the model. Flying with low transmitter or receiver battery may cause loss of control.  
ALWAYS pay attention to your surroundings, and look out for others who are also operating a radio control model nearby.  
ALWAYS check that all screws are tight and not coming loose before flying the model. A single loose screw on the model may cause a major accident.  
ALWAYS perform necessary maintenance and preflight checks to keep the helicopter in a good and safe flying condition.*

*NEVER use the same control frequency as someone else. Doing so may cause interference or loss of control of the model.  
NEVER continue flying if the model is displaying irregular behavior or noises. Bring the model to a halt immediately and disconnect the batteries.  
NEVER fly the model with known broken or defective parts. Always replace damaged parts before attempting to fly again.  
NEVER approach the model while the rotors are still spinning. Doing so can result in serious personal injury.  
NEVER touch the motor immediately after flying. It may be hot enough to cause moderate burns.*

*Operate only outdoors and out of bystanders reach, as the main rotor operates at high rpm and is very dangerous.  
While adjusting and testing, pilots and observers should stand at least 10 meters from the model.  
Novice pilots should be assisted by an experienced pilot and never fly alone!*

<p>Swashplate Servos: Standard size(Qty.3)</p>	<p>ESC: 130HV-250HV Typical</p>	<p>Hex Screwdriver Sizes: 1.5mm     3mm 2mm     4mm*2 2.5mm*2</p>
<p>Tail Servo\Thrttle Servo Standard Size(Qty.1)</p>	<p>Main Blades: Carbon Fiber 690mm - 720mm</p>	<p>     Where indicated, use Thread lock MEDIUM</p> <p></p>
<p>Trasmitter Receiver/Satellites Flybarless Unit</p>	<p>Tail blades: Carbon Fiber 105mm to 116mm</p>	<p>     Wicking compound bearing retainer</p> <p></p>
<p>Battery Pack (Typical): LiPo 6s 4000-5500mAh * 2 or LiPo 7s 4000-5500mAh * 2</p>	<p>Motor: 4525-4530 500kv-550kv Typical</p>	<p>Thrust Bearing Grease Pitch Gauge</p>

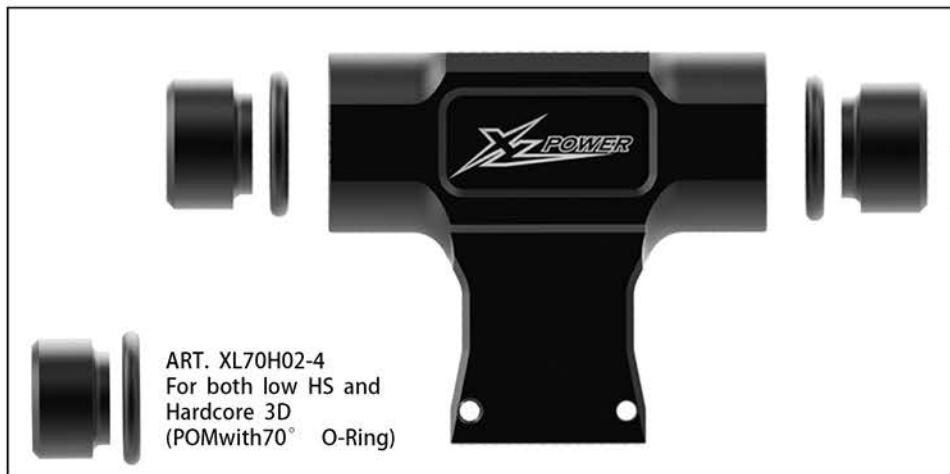

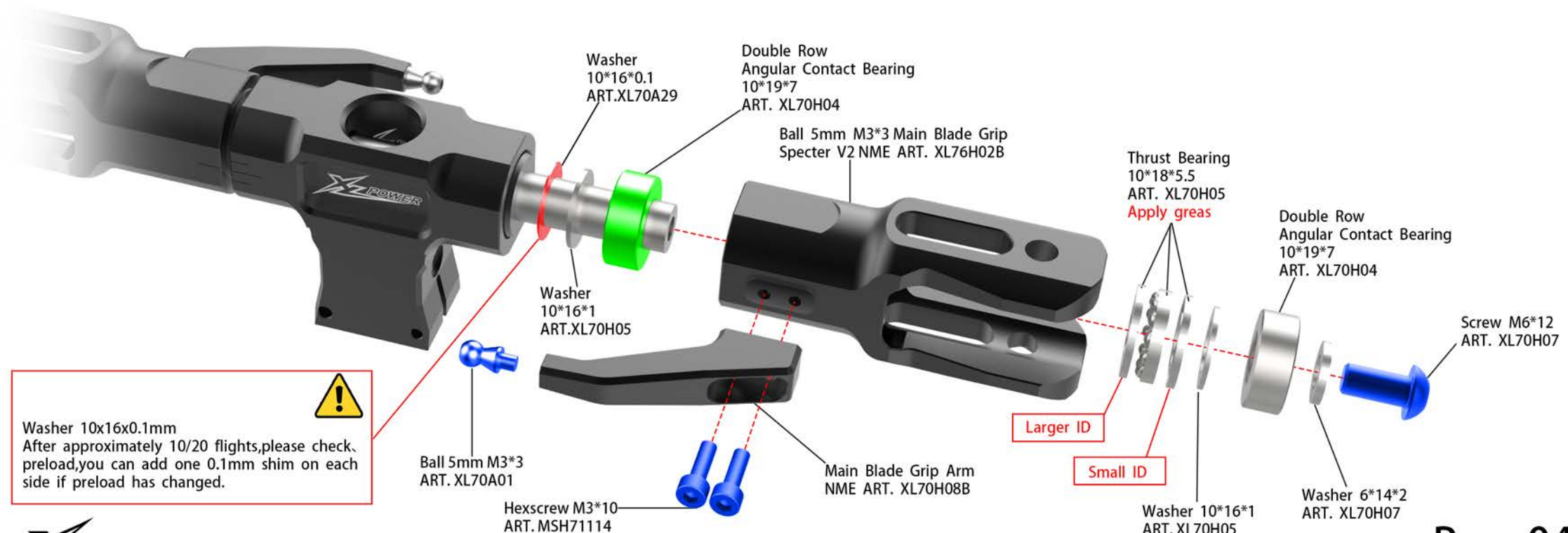
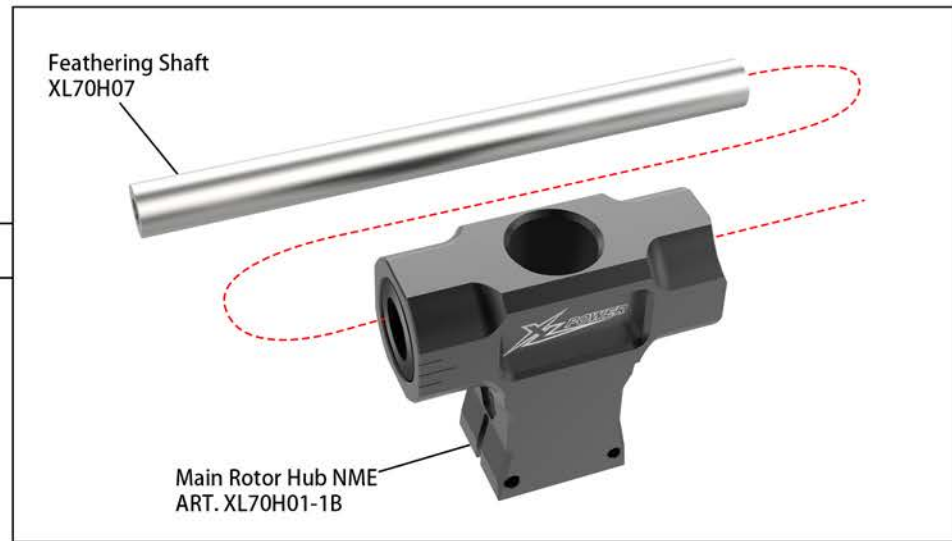

Head Dampener

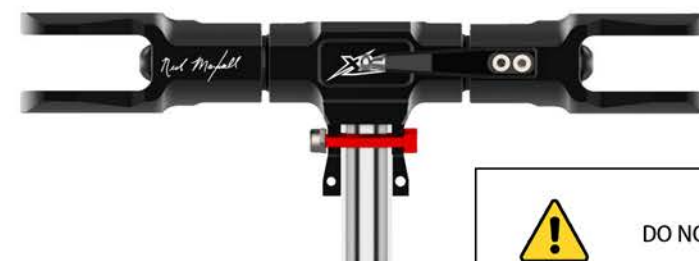
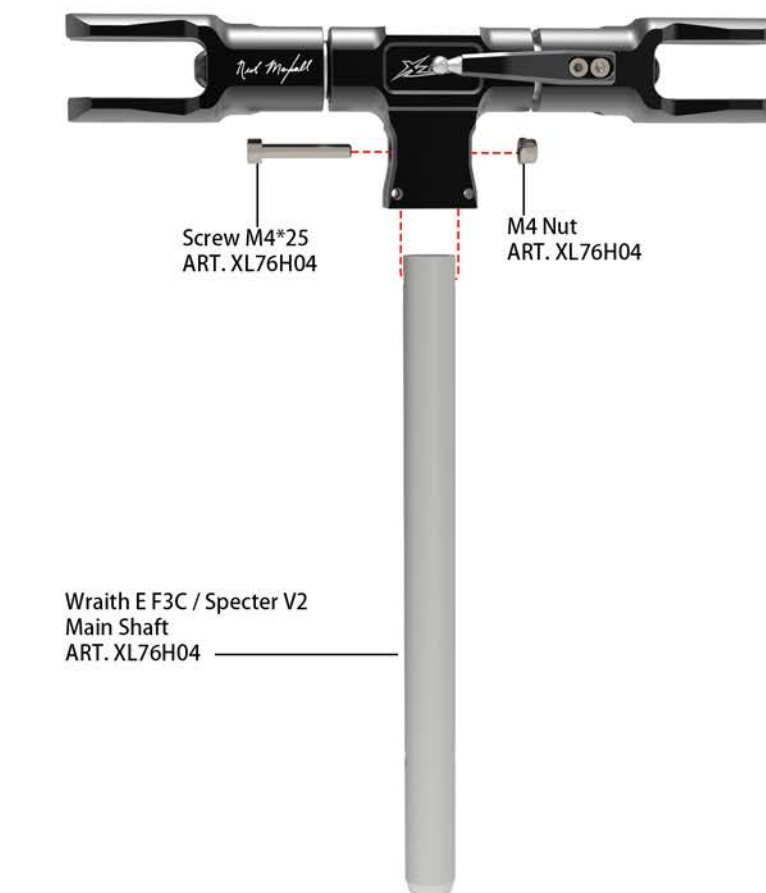
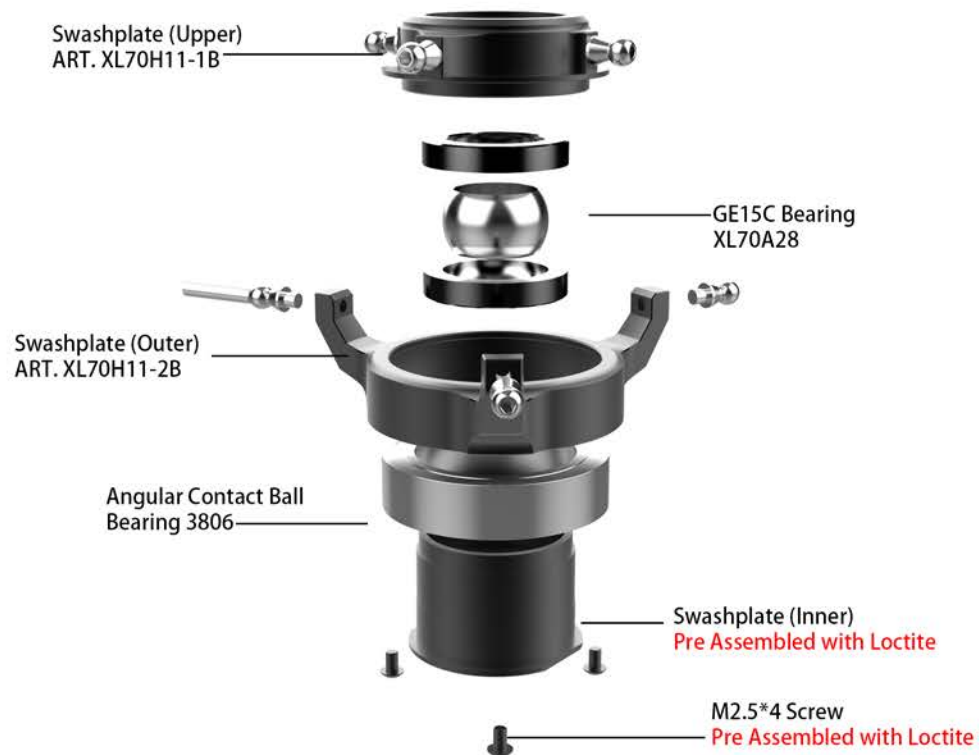

**!**

Washer 10x16x0.1mm  
After approximately 10/20 flights, please check preload, you can add one 0.1mm shim on each side if preload has changed.



 DO NOT TIGHTEN YET

Fully tighten M4\*25 screw

Spacer 3\*5\*0.5  
ART. XL70H09B

Control arm NME  
ART.XL70H09B

Ball Bearing  
3\*7\*3  
ART. XL52A12  
ART.XL70H09B

Radius Arm  
ART.XL70H09  
ART.XL70H10

Pin 3\*14  
ART.XL70H09B

 Pinch bolts together

**x2**

Screw M3\*25  
ART. XL70H09B

Spacer 3\*5\*0.5  
ART. XL70H09B

  
Pre Assembled

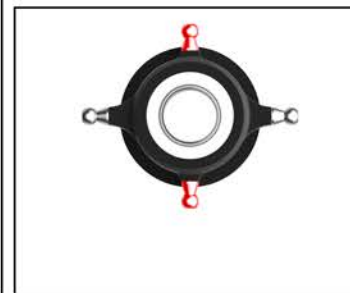
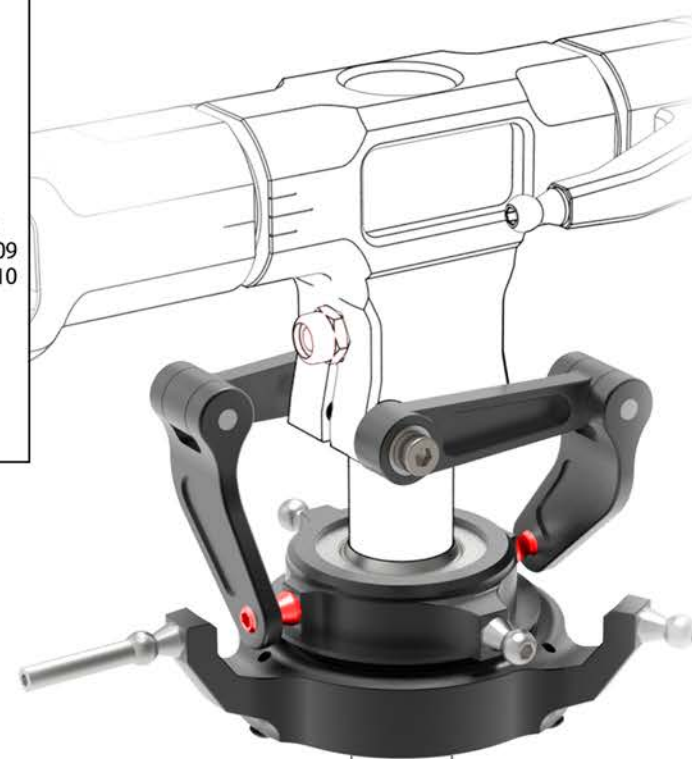

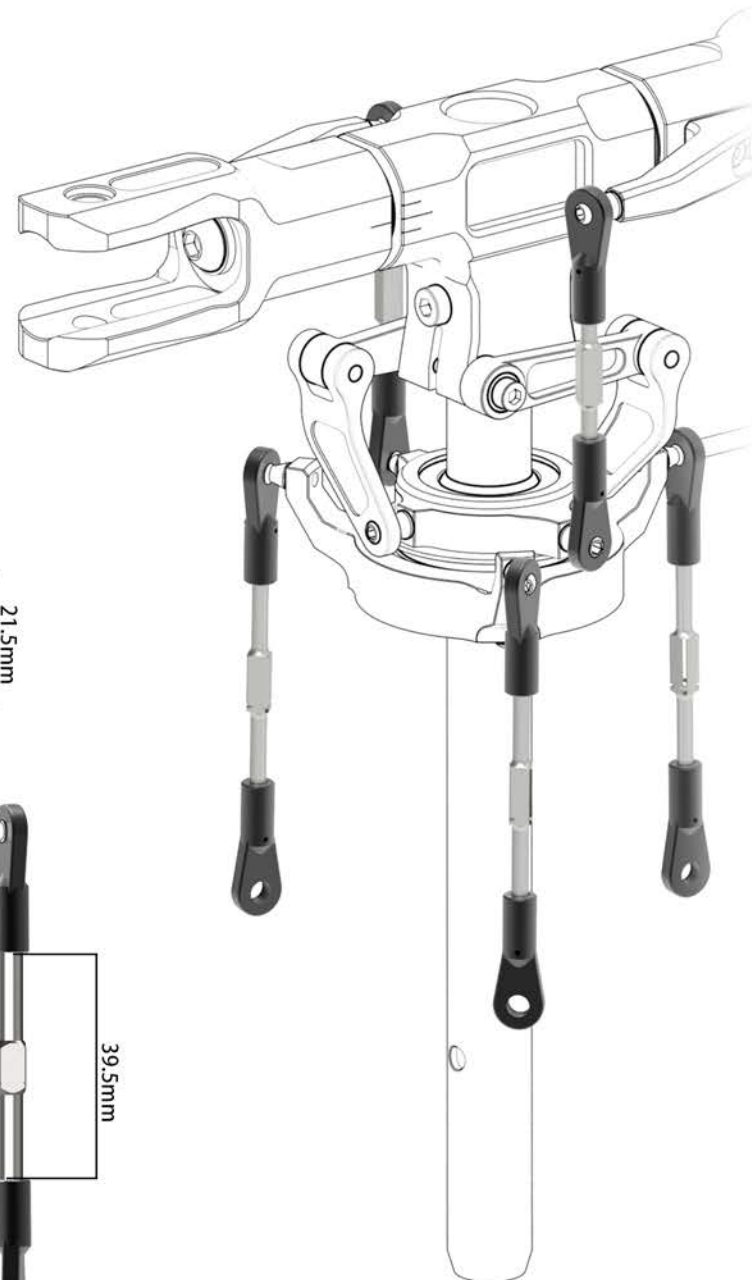
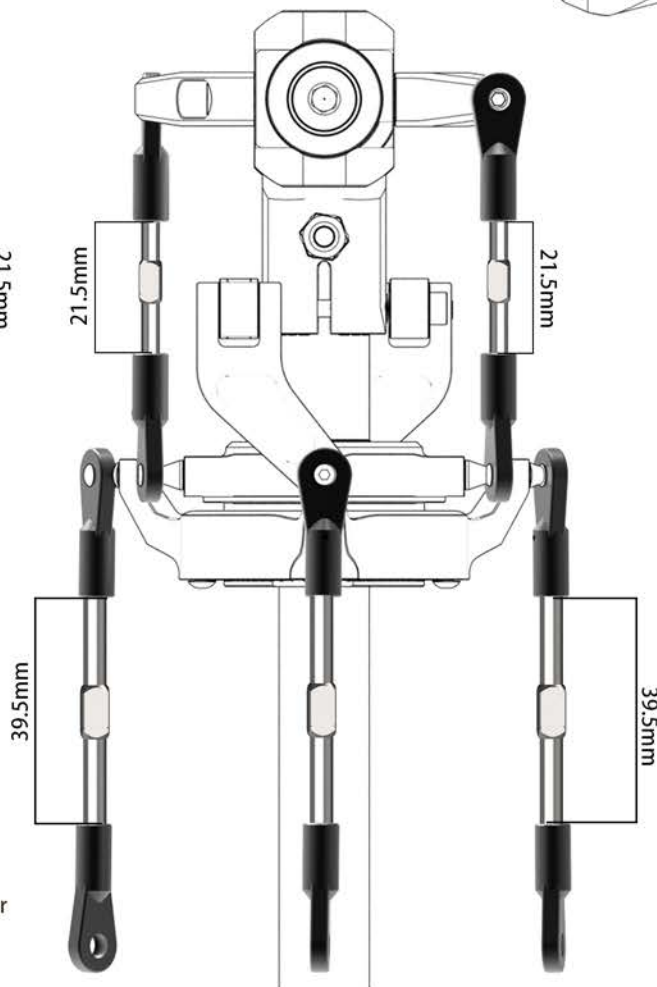
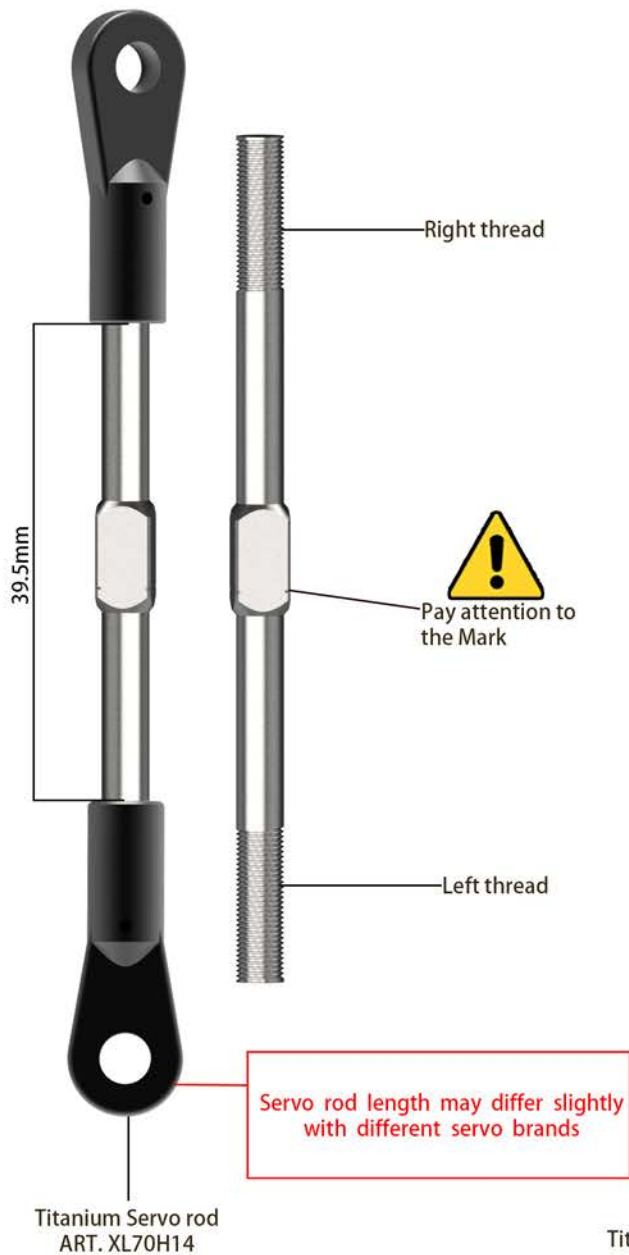

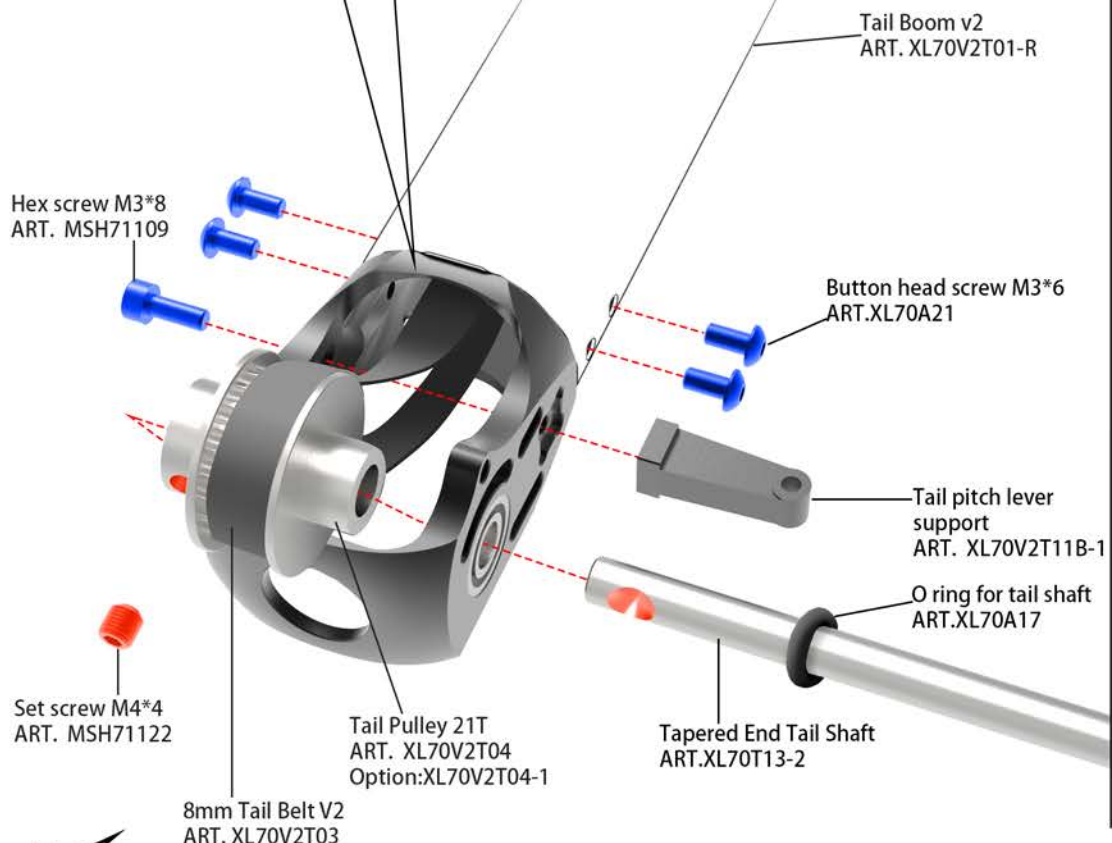
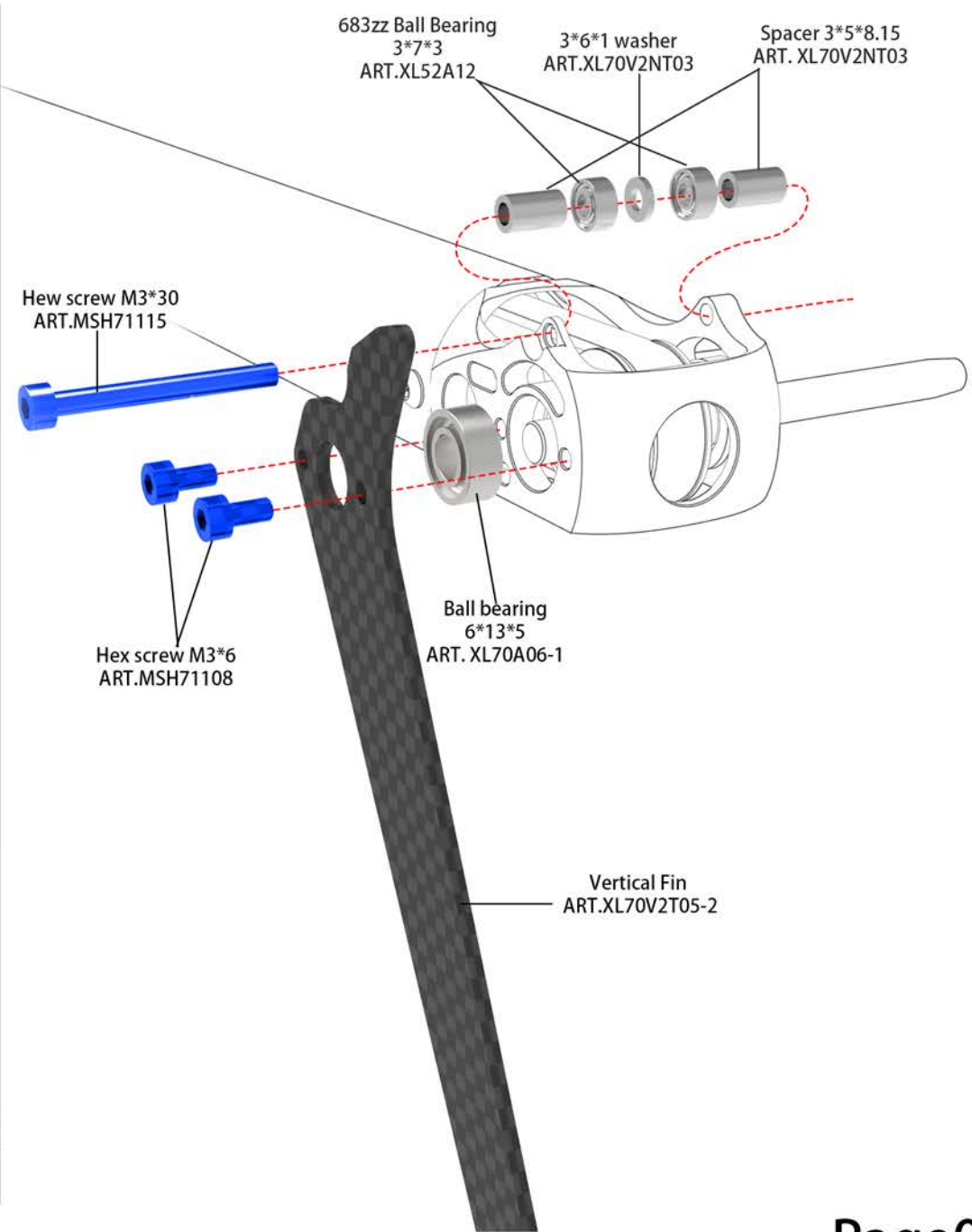
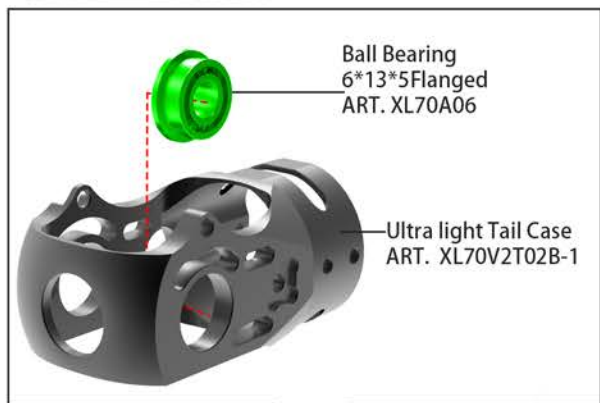



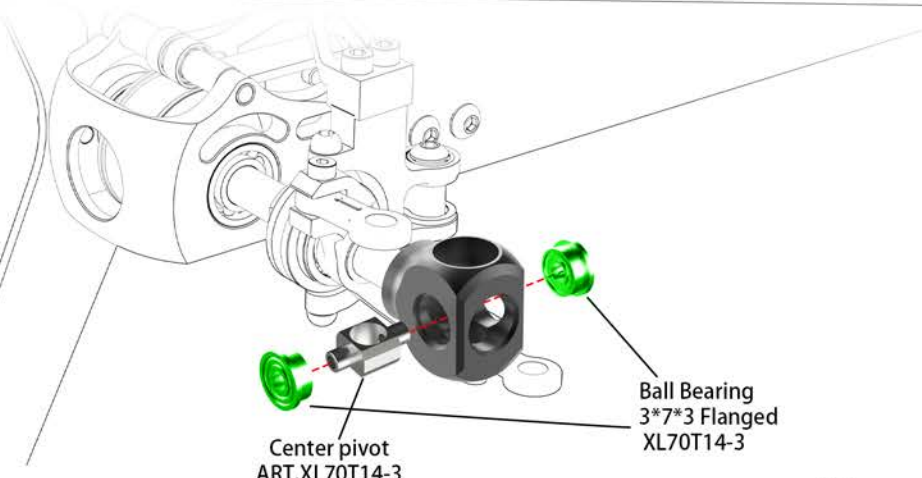
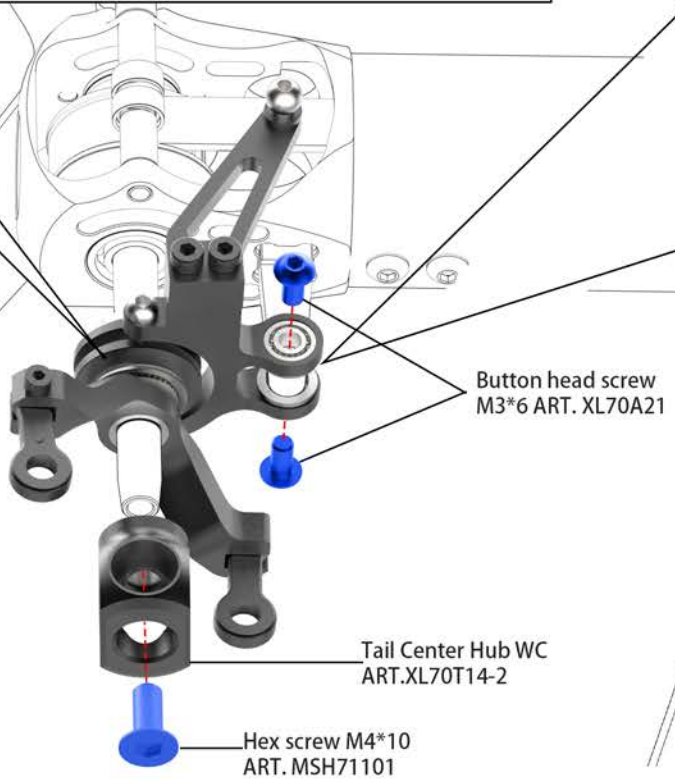
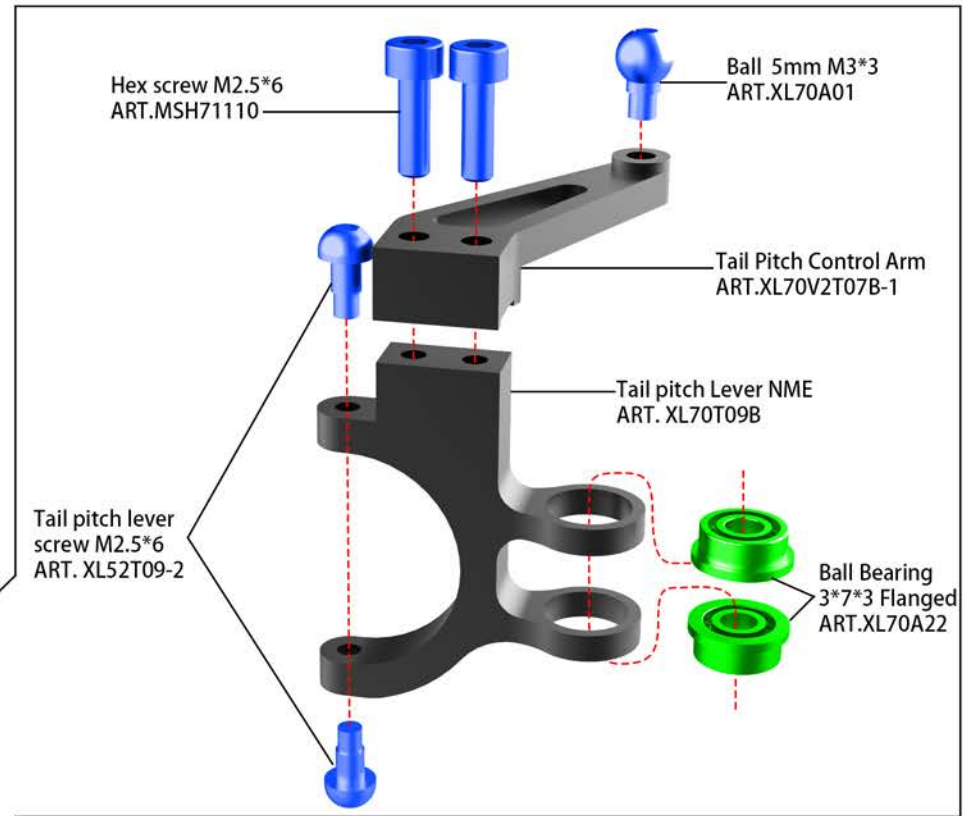
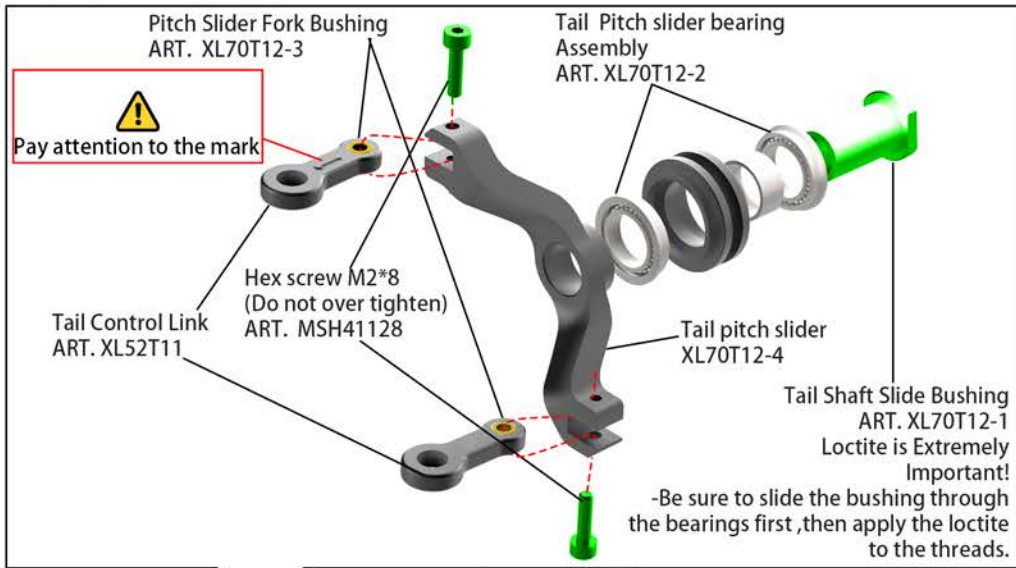

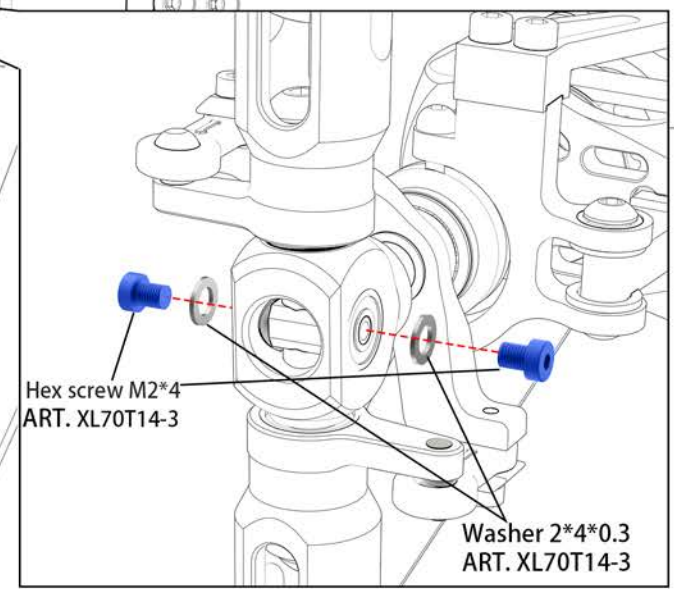
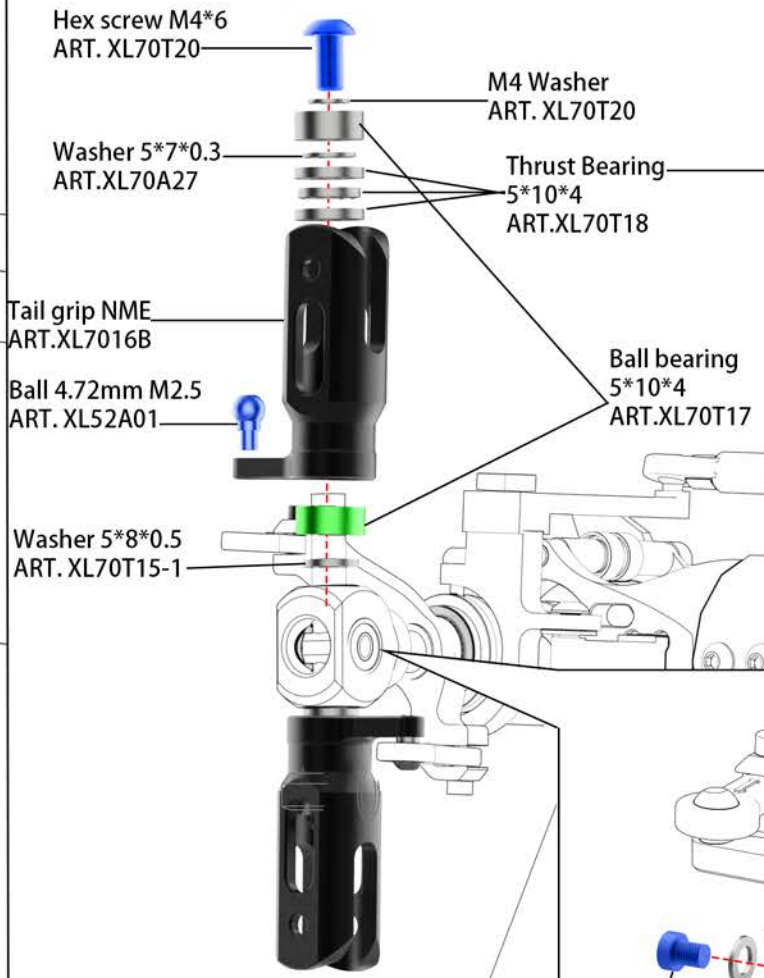
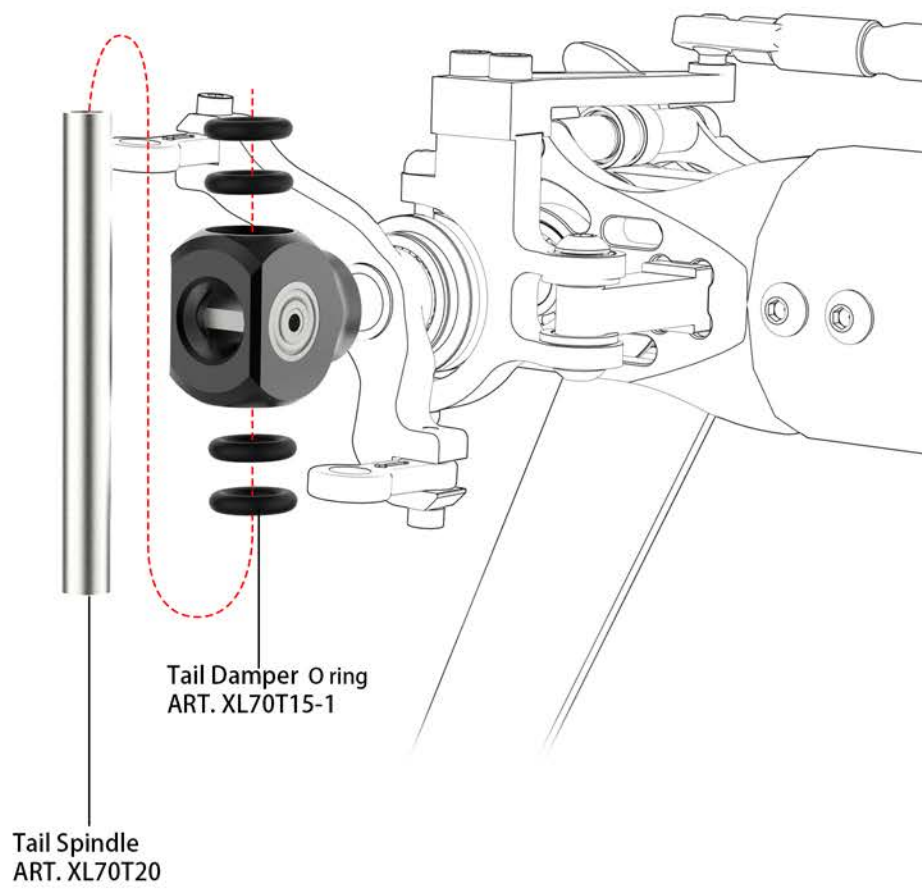

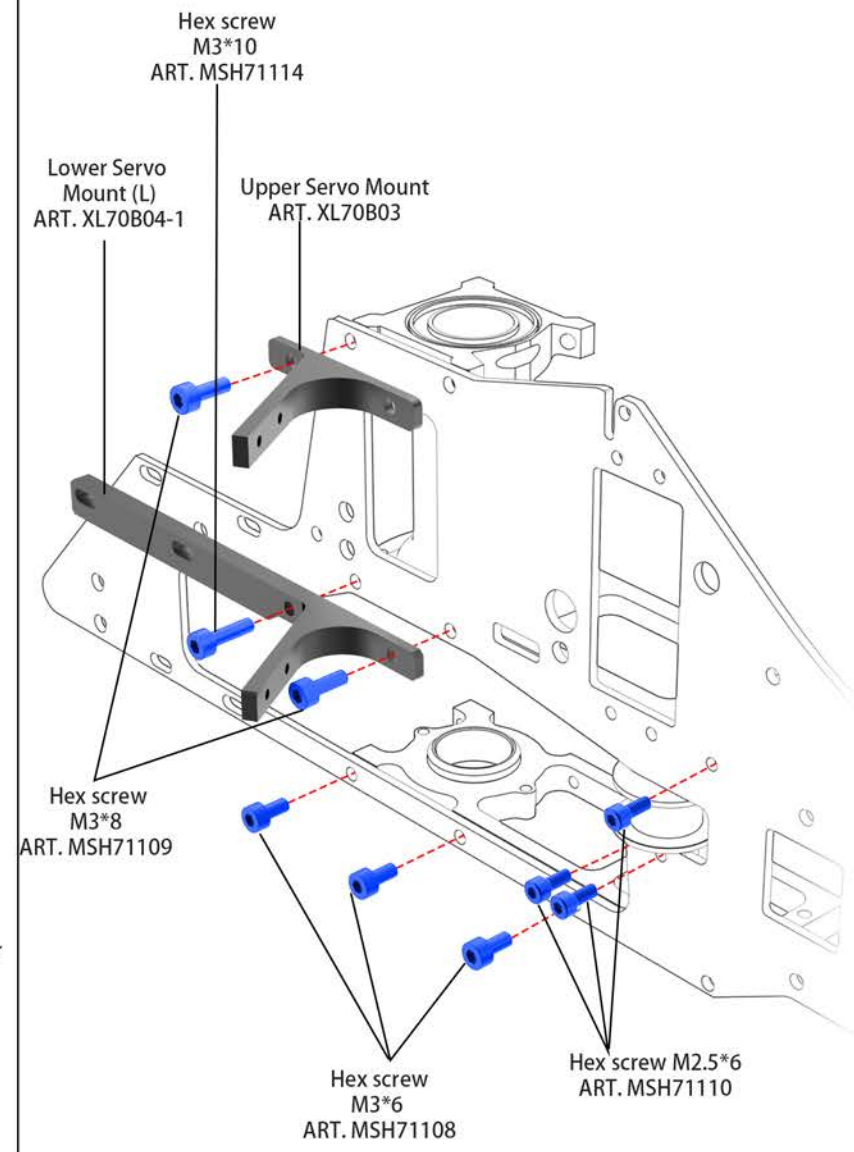
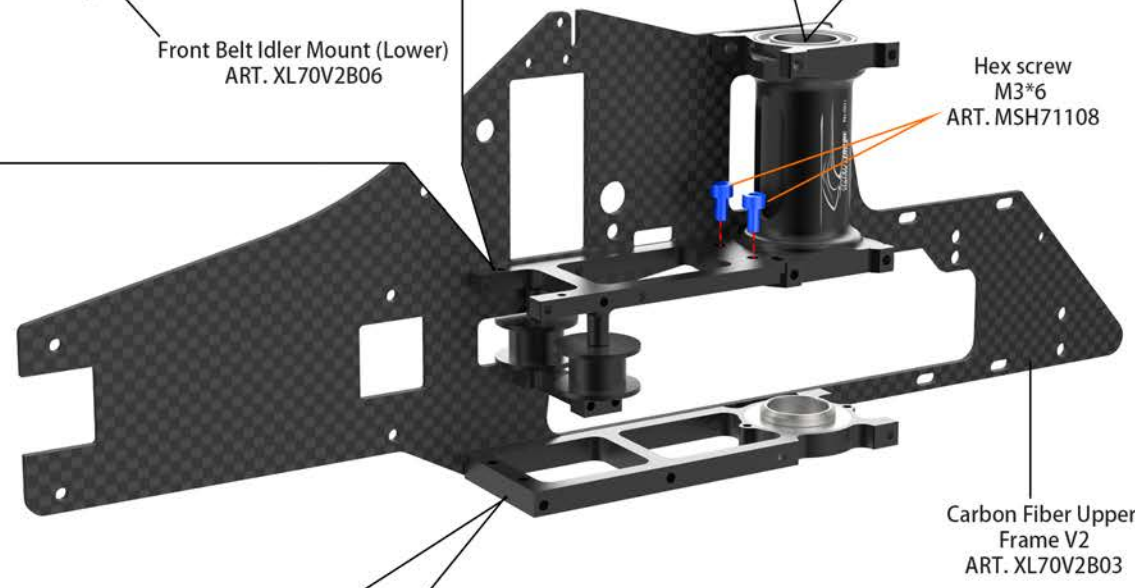
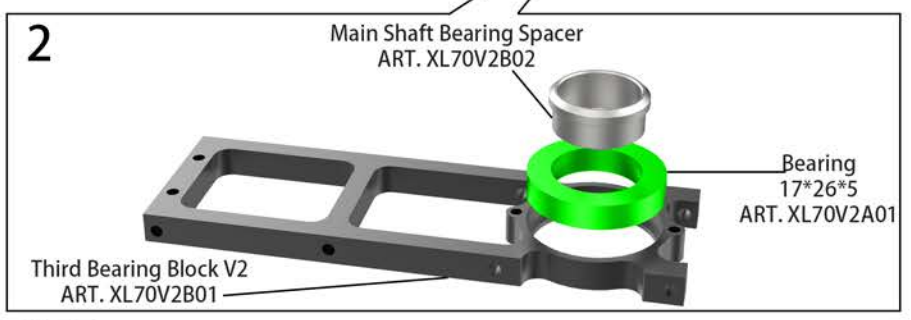
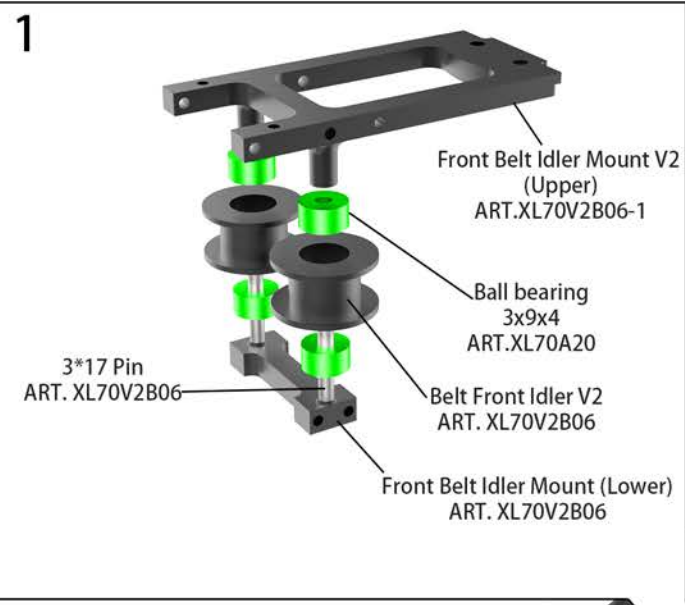

Pom Anti-Rotation Bracket  
ART. XL70B13-2

Hex screw M3\*8  
ART. XL70B13-2

Anti-Rotation  
Bracket Mount WC  
ART. XL70B13-3

Hex screw M2.5\*6  
ART. MSH71110

**!** Do Not Install This Silver Screw Yet

Flat screw M3\*4  
ART. XL70V2B05

Carbon Fiber Plate  
ART. XL70V2B07

Threaded

Tail Boom Clamp V2  
ART. XL70V2B05

**!** Unthreaded Hole Faces Right

Set screw M3\*12  
ART. XL70V2B04-1

Alu spacer  
ART. XL70V2B04-1

Ball 5mm M3\*12  
ART. XL70V2B04-1

Hex screw M3\*6  
ART. MSH71108

Hex screw  
M3\*14  
ART. MSH71112

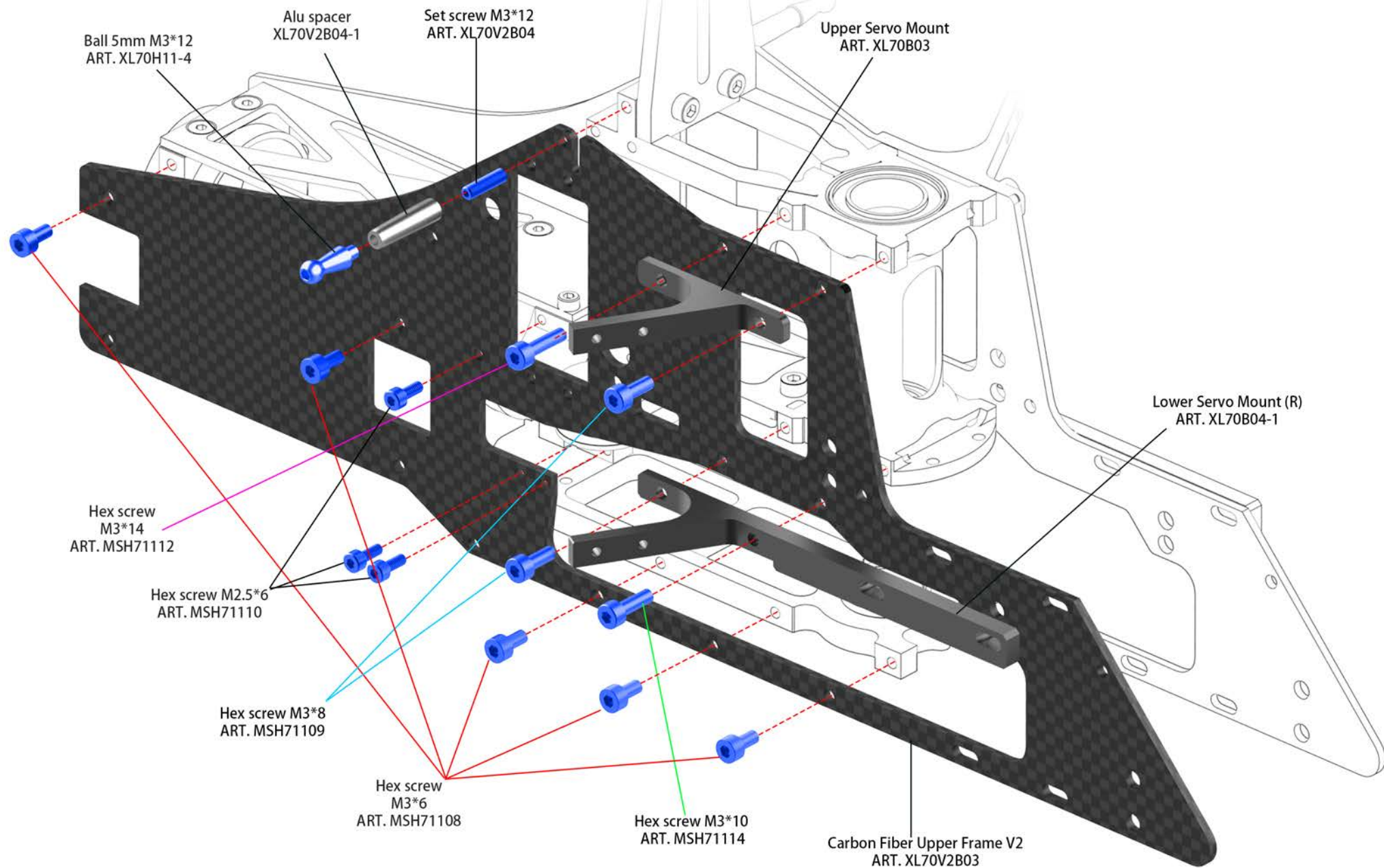



The exact number of "Carbon Servo Washer 2mm" you use will vary depending on the exact servo and servo horn used. Only add enough spacers to prevent the tail servo from binding on the elevator servo arm/ball throughout it's full range of travel.

Servo Horn For 520/550  
XL52A19



Ball 5mm M2\*4.8  
ART.XL70A26

M2 nut  
MSH71095

Hex screw  
M3\*6  
ART. MSH71108

Carbon Servo Washer  
ART. MSH71032

Carbon Servo Washer  
ART. MSH71032

Carbon Servo Washer  
ART.XL70V2A02

Hex Screw M2.5\*10  
ART. MSH71032

Carbon Servo Washer  
ART. MSH71032



14-17mm

×2

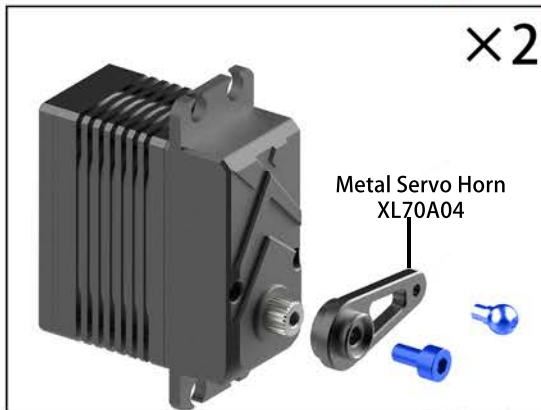

Metal Servo Horn  
XL70A04

×1

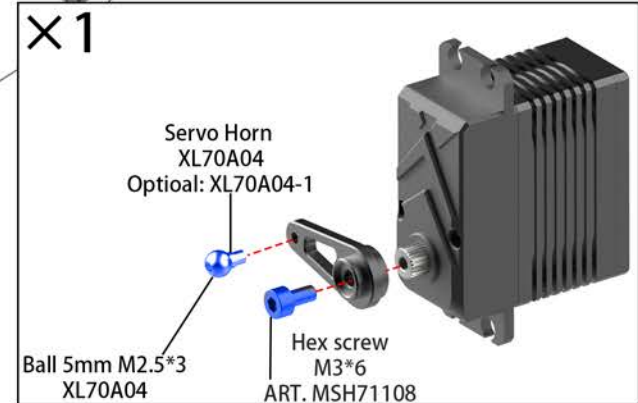

Servo Horn  
XL70A04  
Optioal: XL70A04-1

Ball 5mm M2.5\*3  
XL70A04

Hex screw  
M3\*6  
ART. MSH71108

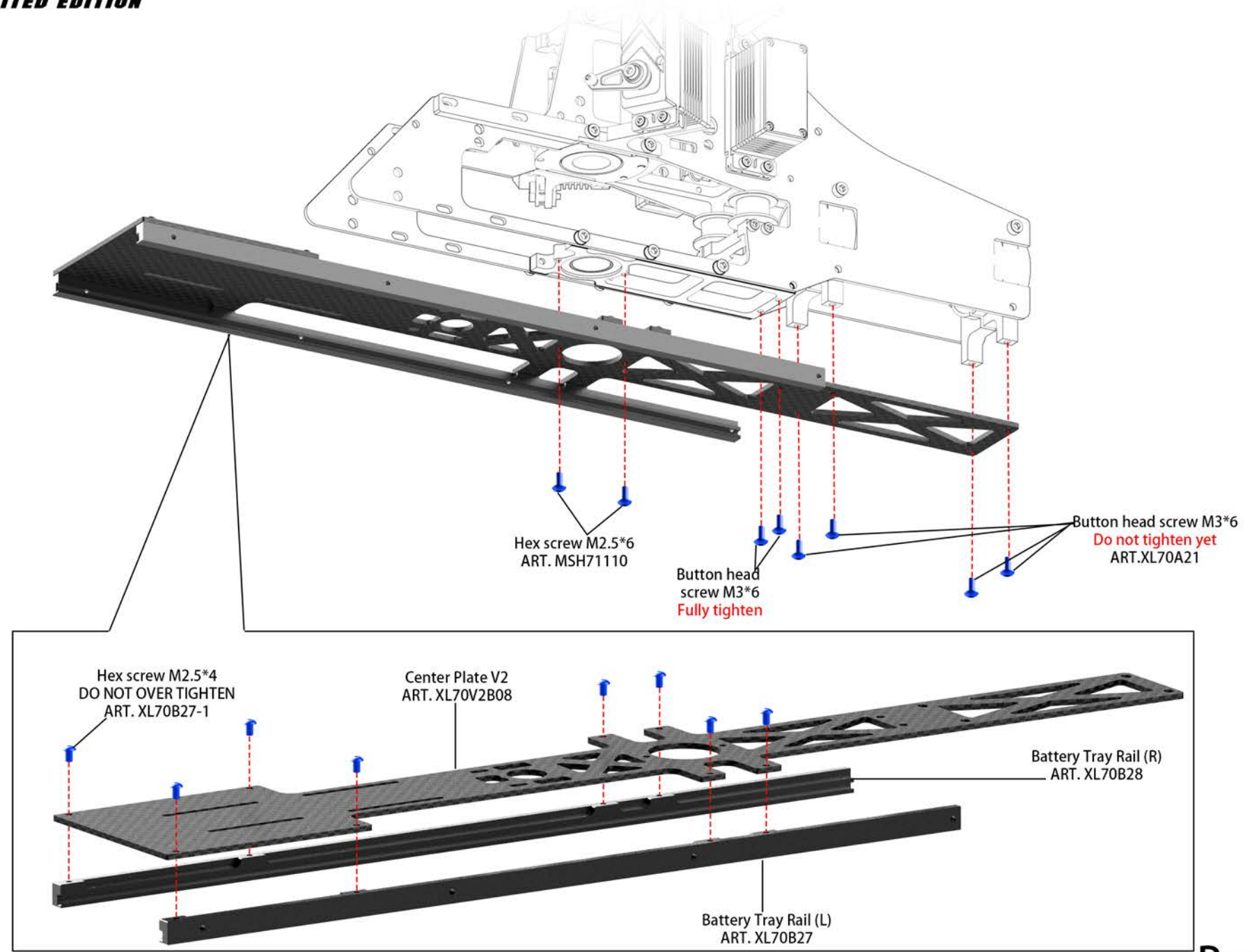

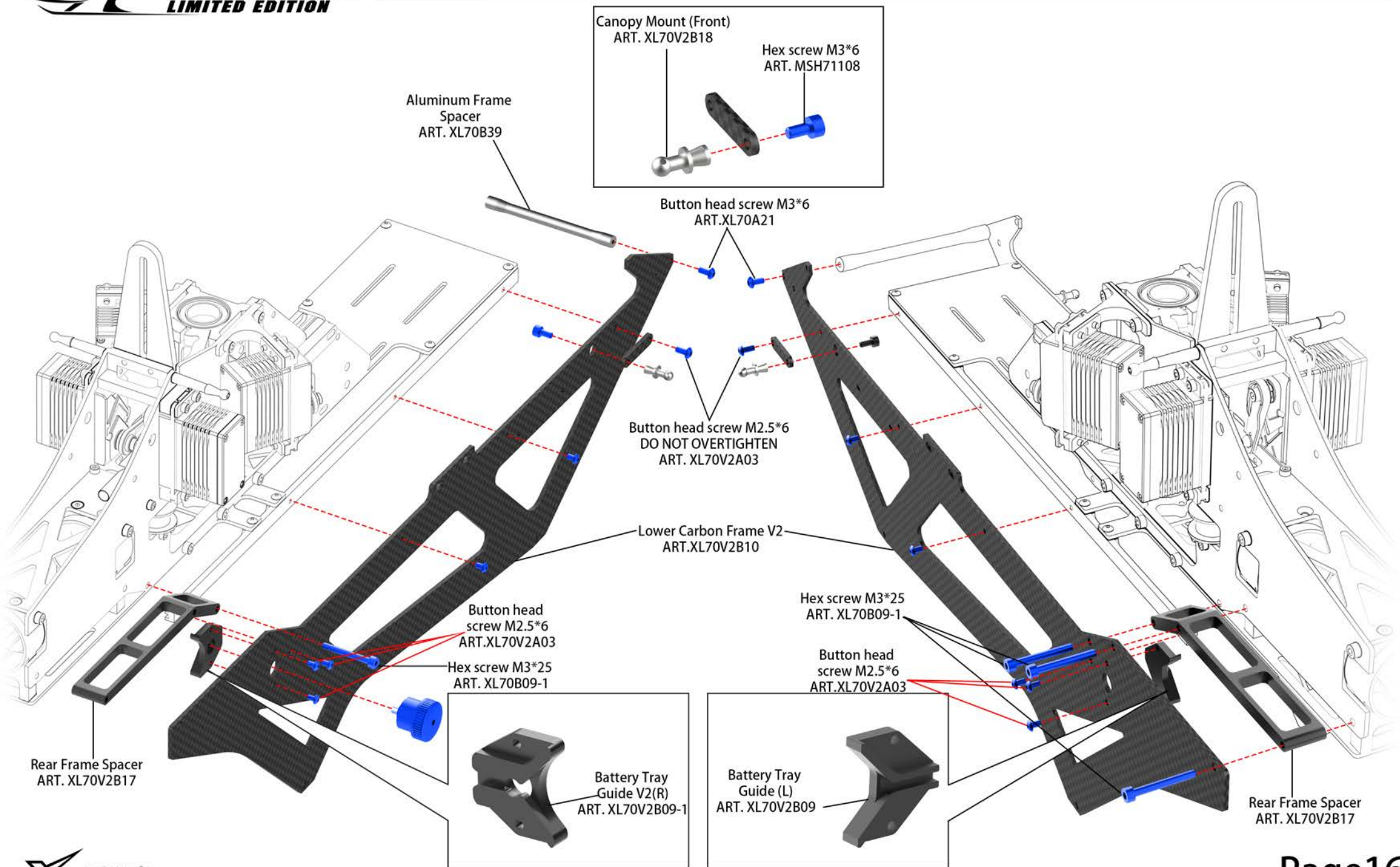



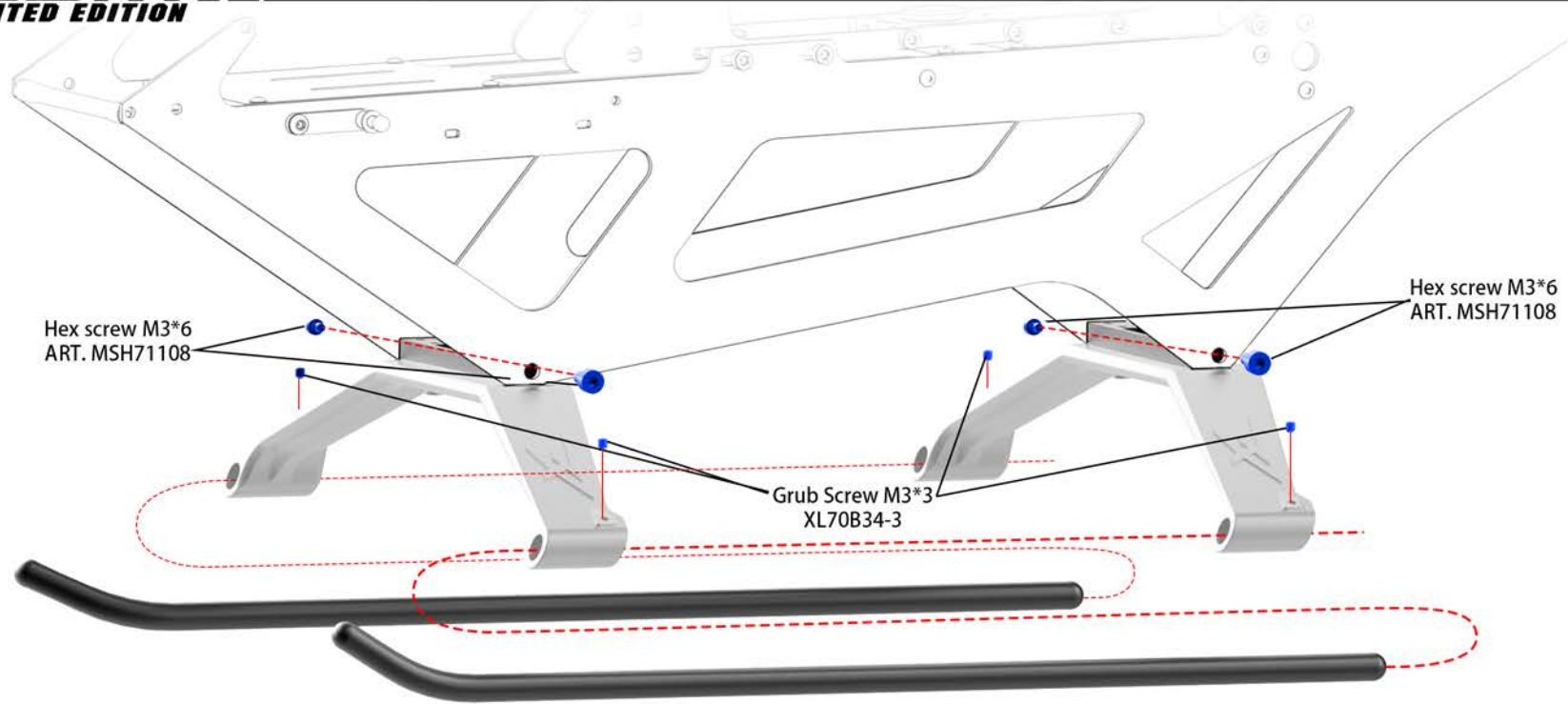

Hex screw M3\*6  
ART. MSH71108

Hex screw M3\*6  
ART. MSH71108

Grub Screw M3\*3  
XL70B34-3

×2

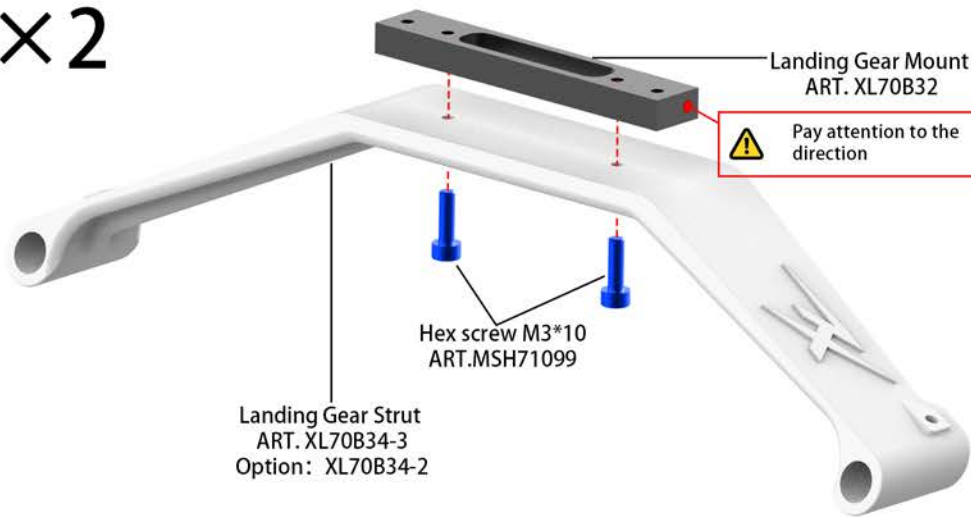

Landing Gear Mount  
ART. XL70B32

⚠ Pay attention to the direction

Hex screw M3\*10  
ART. MSH71099

Landing Gear Strut  
ART. XL70B34-3  
Option: XL70B34-2

×2

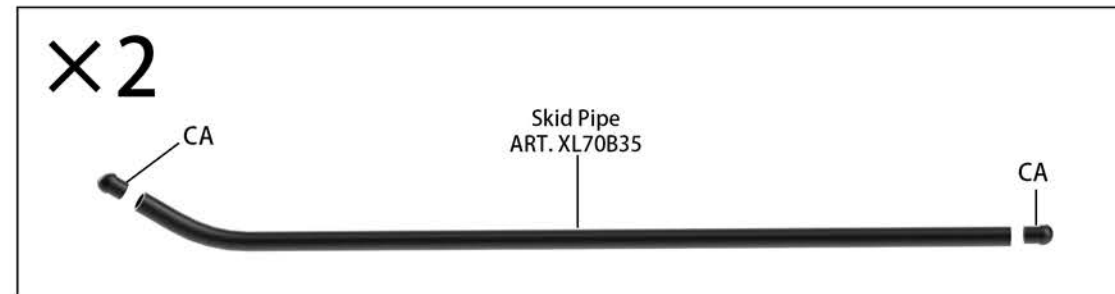

Skid Pipe  
ART. XL70B35

CA

CA

Button Head screw M3\*14  
ART. XL70V2B12

Ball bearing  
15\*21\*4  
ART. XL70B21-3

Upper one way hub  
ART. XL70V2B21

100T Front Pulley  
ART. XL70V2B12

Hex screw M4\*25  
Into Main Shaft  
ART. XL70A23

One way bearing  
(pay attention to the direction)  
You may add grease to  
one-way bearing  
ART. XL70B21-1

Lower one way hub  
ART. XL70V2B21

Grub screw M4\*4  
ART. XL70H13-1  
MSH71122



Hex screw M3\*12  
ART. XL70H13-1  
MSH51149

-Pull up main shaft  
-Push down shaft collar  
-Fully tighten M3\*12

18mm Heavy Duty Main Gear 106T V2  
(ART. XL70V2B11-1)Included in Kit

Ball bearing  
15\*21\*4  
ART. XL70B21-3

Option:  
Main Gear 106T Mod1 (ART. XL70B20)  
Must use V1 Pinions (ART. XL70G10, XL70G11, XL70G12)  
Main Gear 109T Mod1 (ART. XL70B20-1)  
Must use V2 Pinions (ART. XL70G11-1, XL70G12-1, XL70G13)

Check the rotation direction during the installation of the belt

Turn belt 90 degree CCW

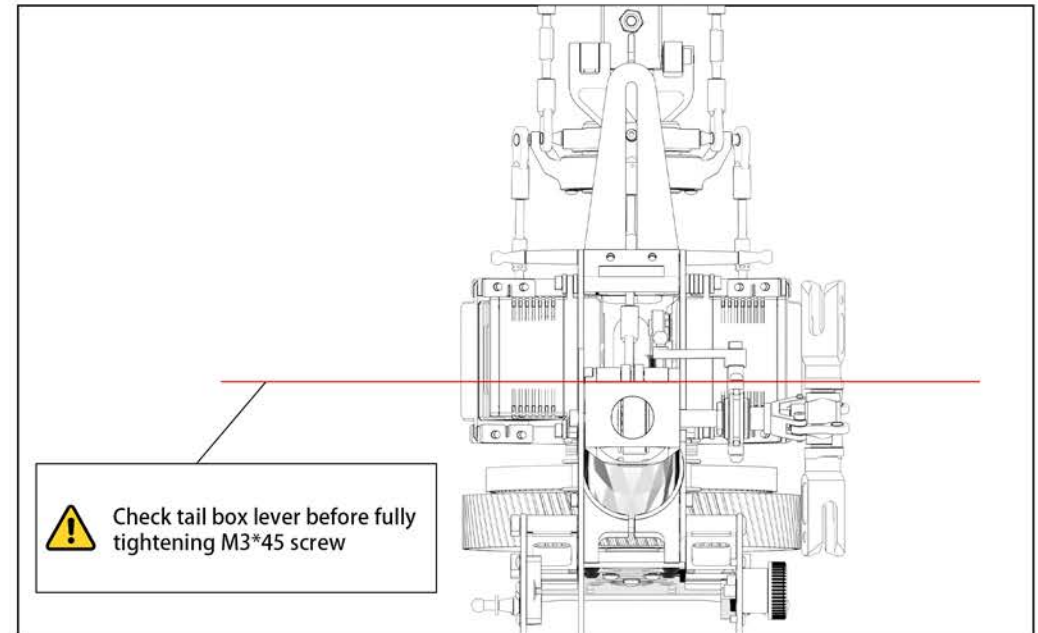
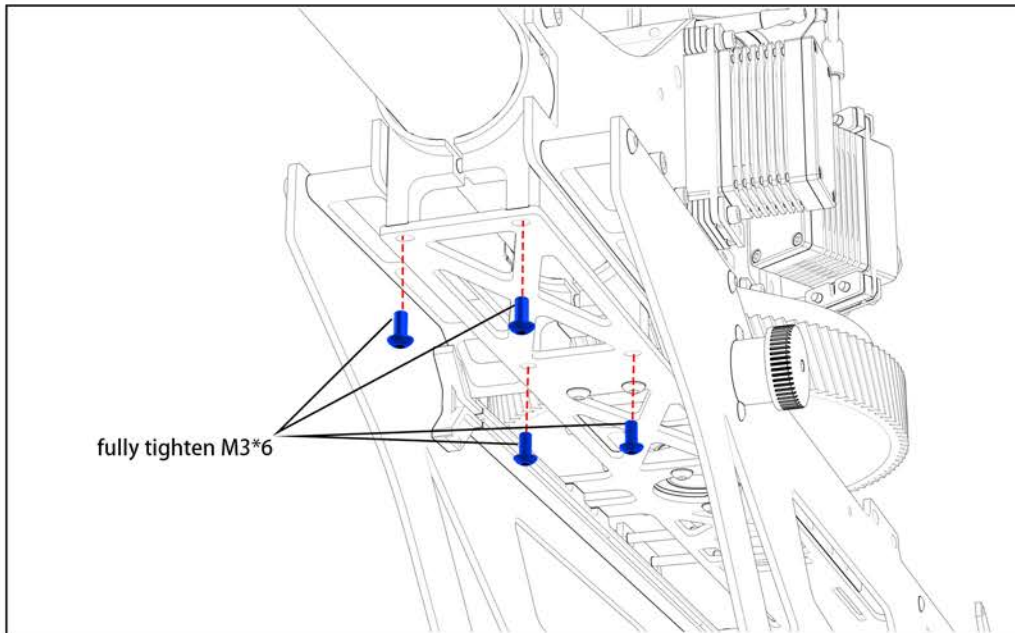
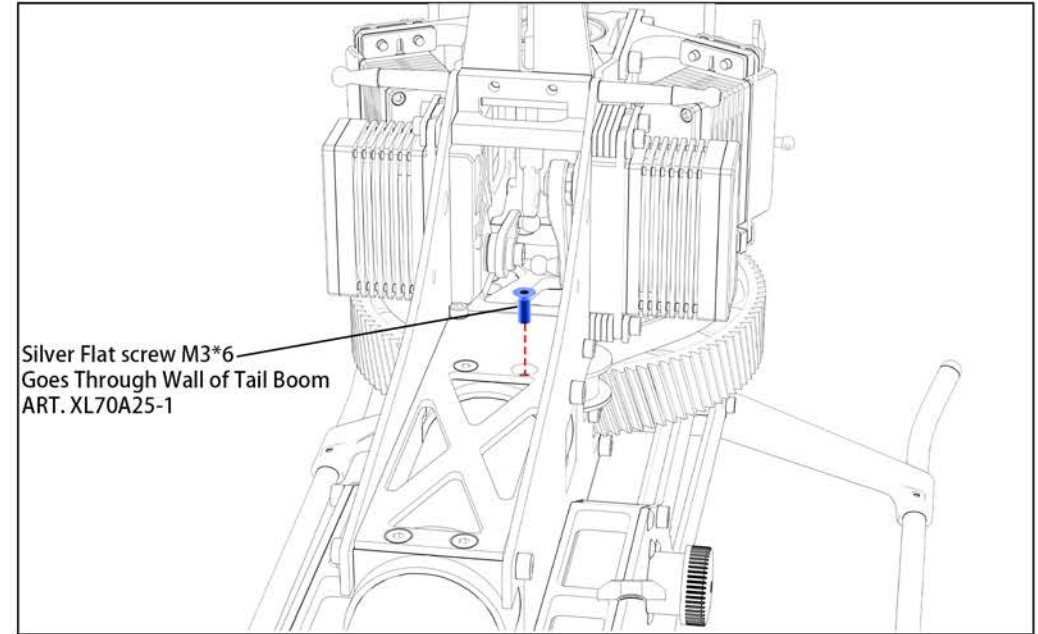
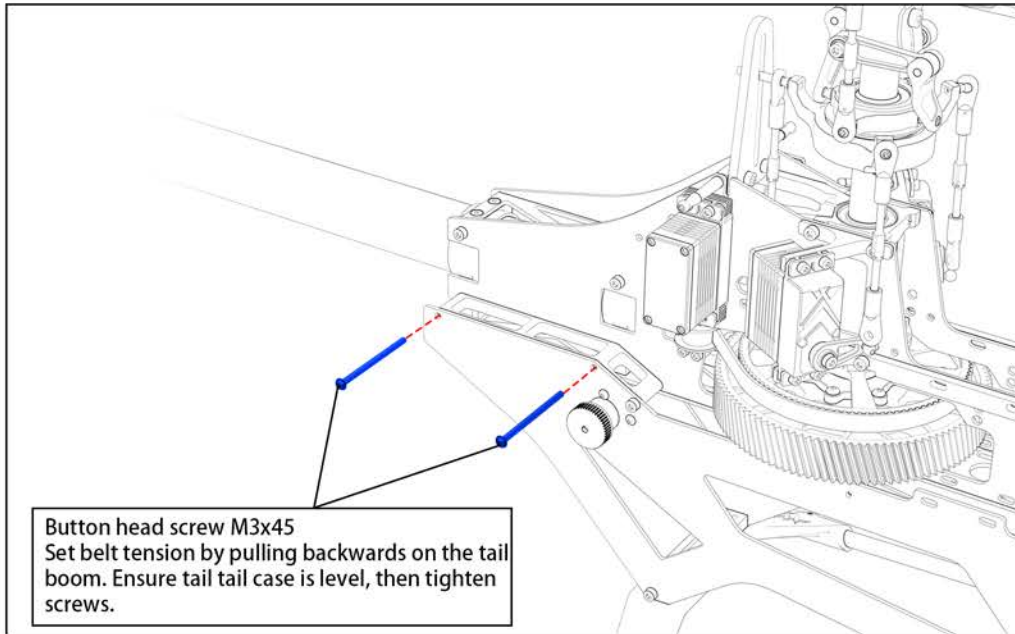

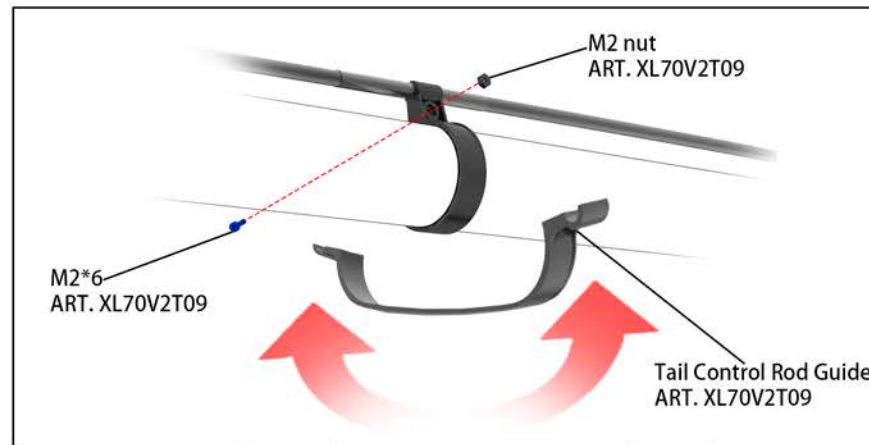
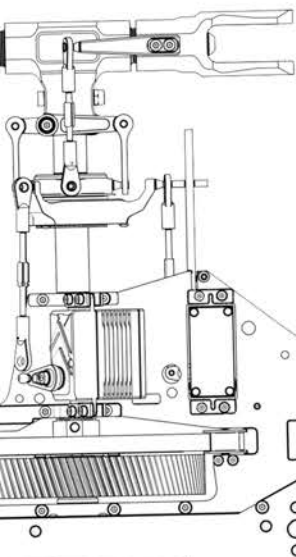

Attach the tail rod guide slightly offset from the exact middle of the tail boom, bias towards the tail case

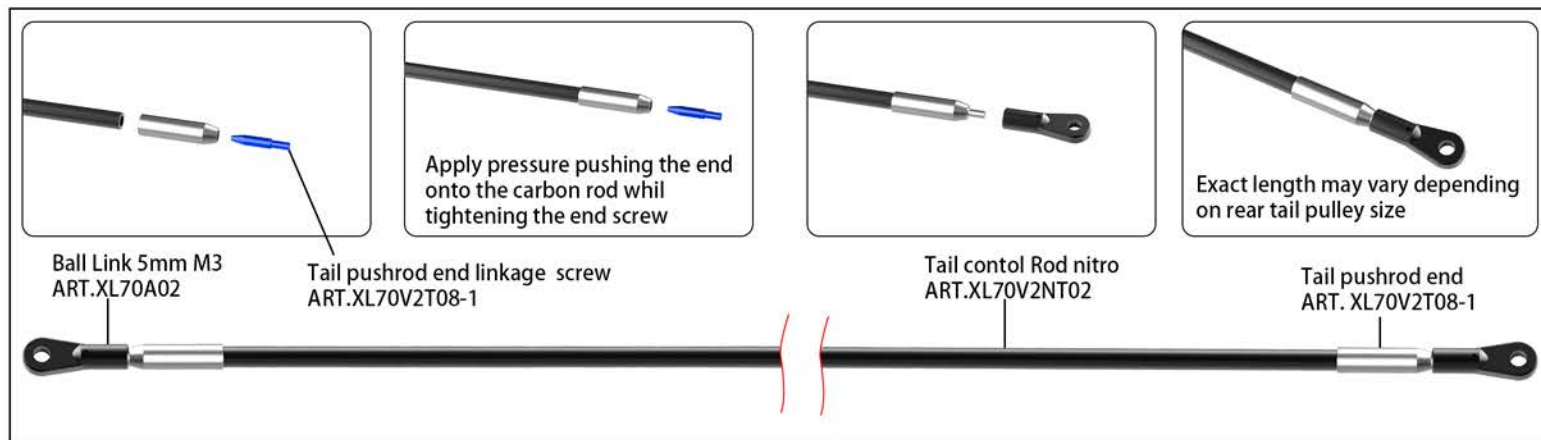

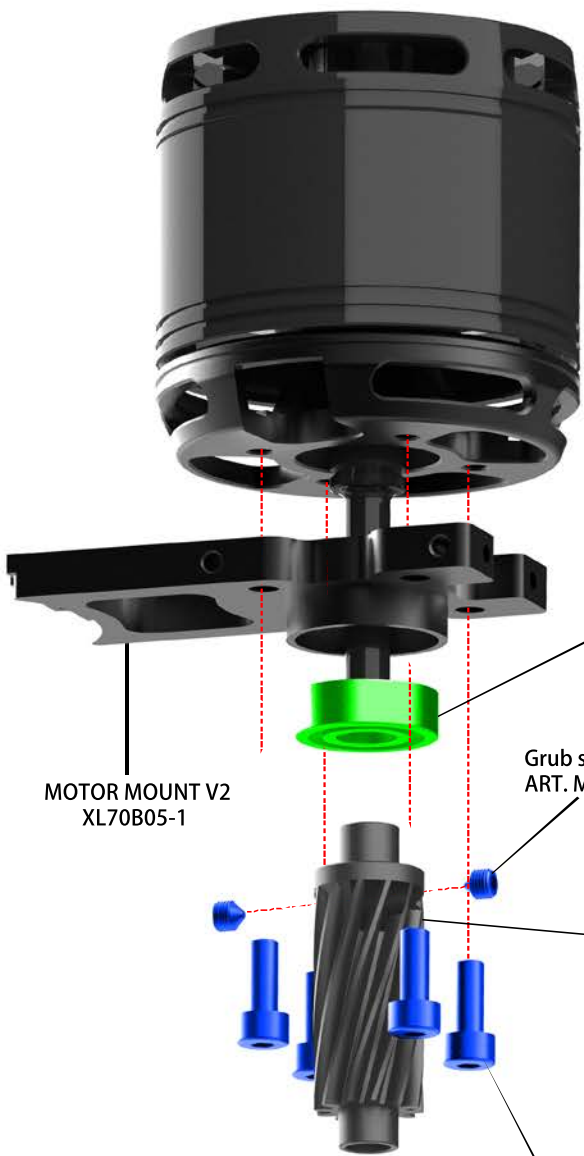

MOTOR MOUNT V2  
XL70B05-1

Grub screw M4\*4  
ART. MSH71122

Hex screw M4x10  
ART. MSH71116

 Pay attention to the bearing direction (Pre-assembled)

UP



Down

Motor pinion 11T  
ART. XL70G11  
Included in Kit  
Option:  
XL70G10  
XL70G12  
XL70G11-1 for XL70B20-1  
XL70G12-1 for XL70B20-1  
XL70G13 for XL70B20-1

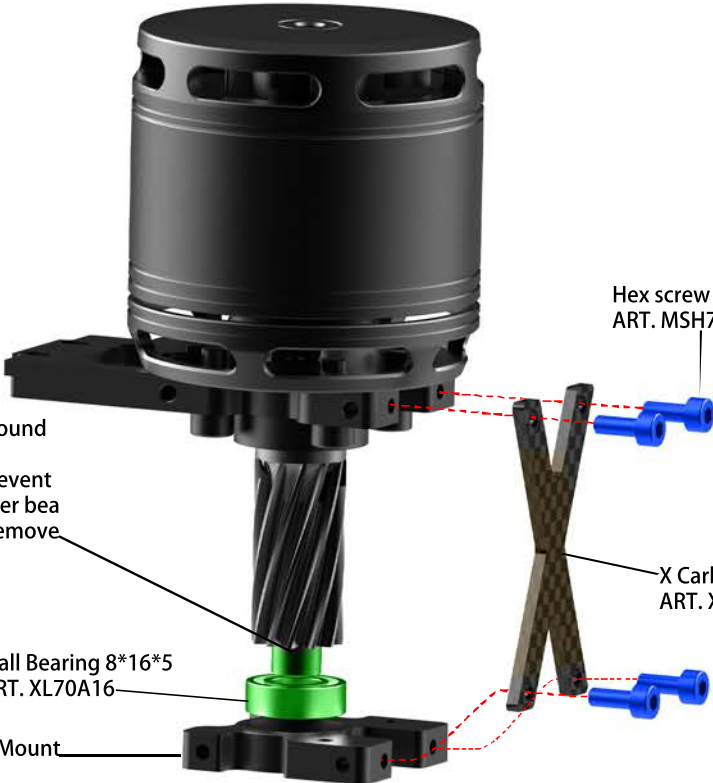

Hex screw M3x6  
ART. MSH71108

X Carbon Fiber Brace  
ART. XL70B08

Ball Bearing 8\*16\*5  
ART. XL70A16

Lower Motor Mount  
ART. XL70B07

Add a small dab of green retaining compound (638/648/680/620) to outside of pinion to prevent wear to pinion and inner bearing race. Use heat to remove for maintenance.

 Pay attention to the bearing direction (Pre-assembled)



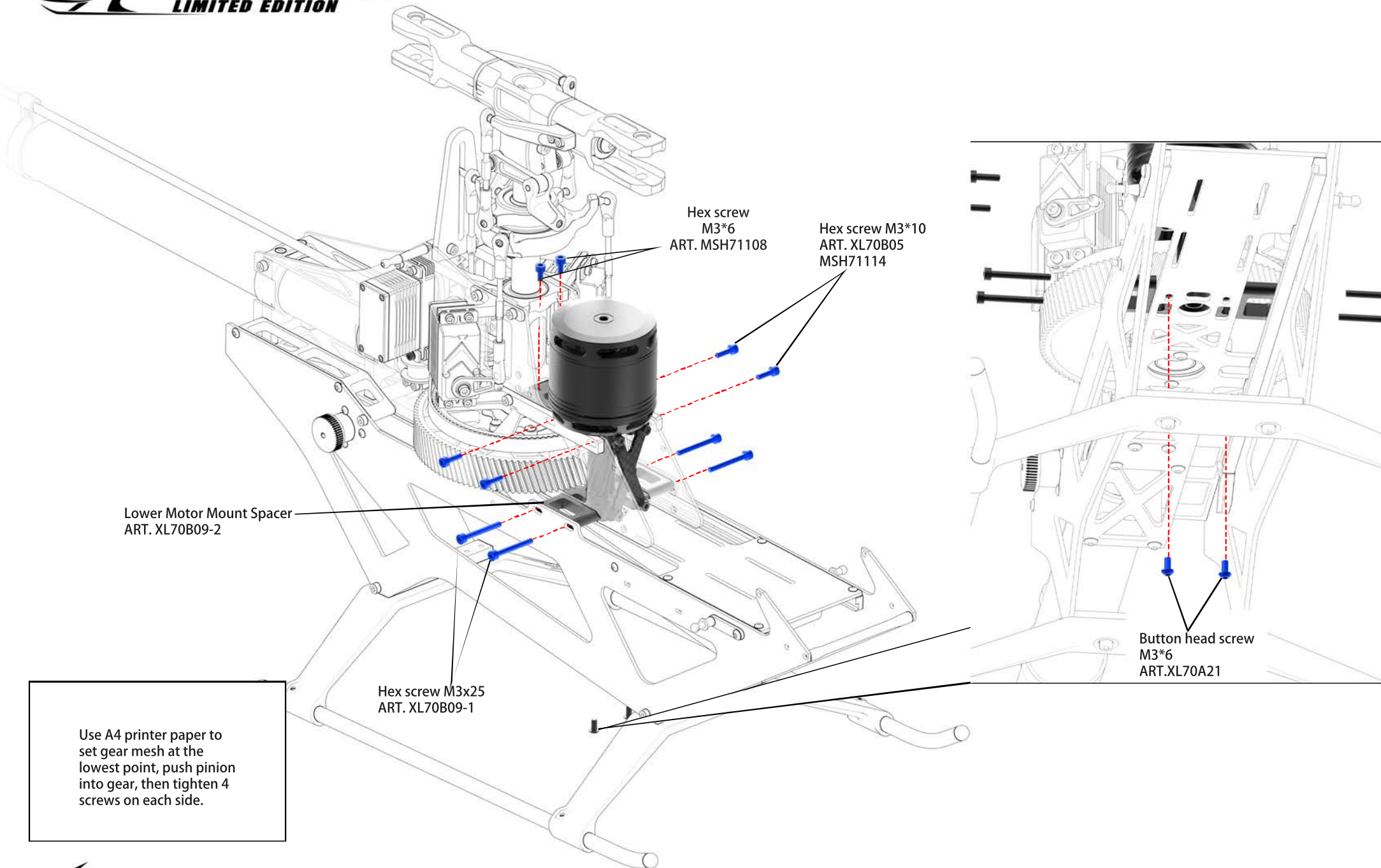

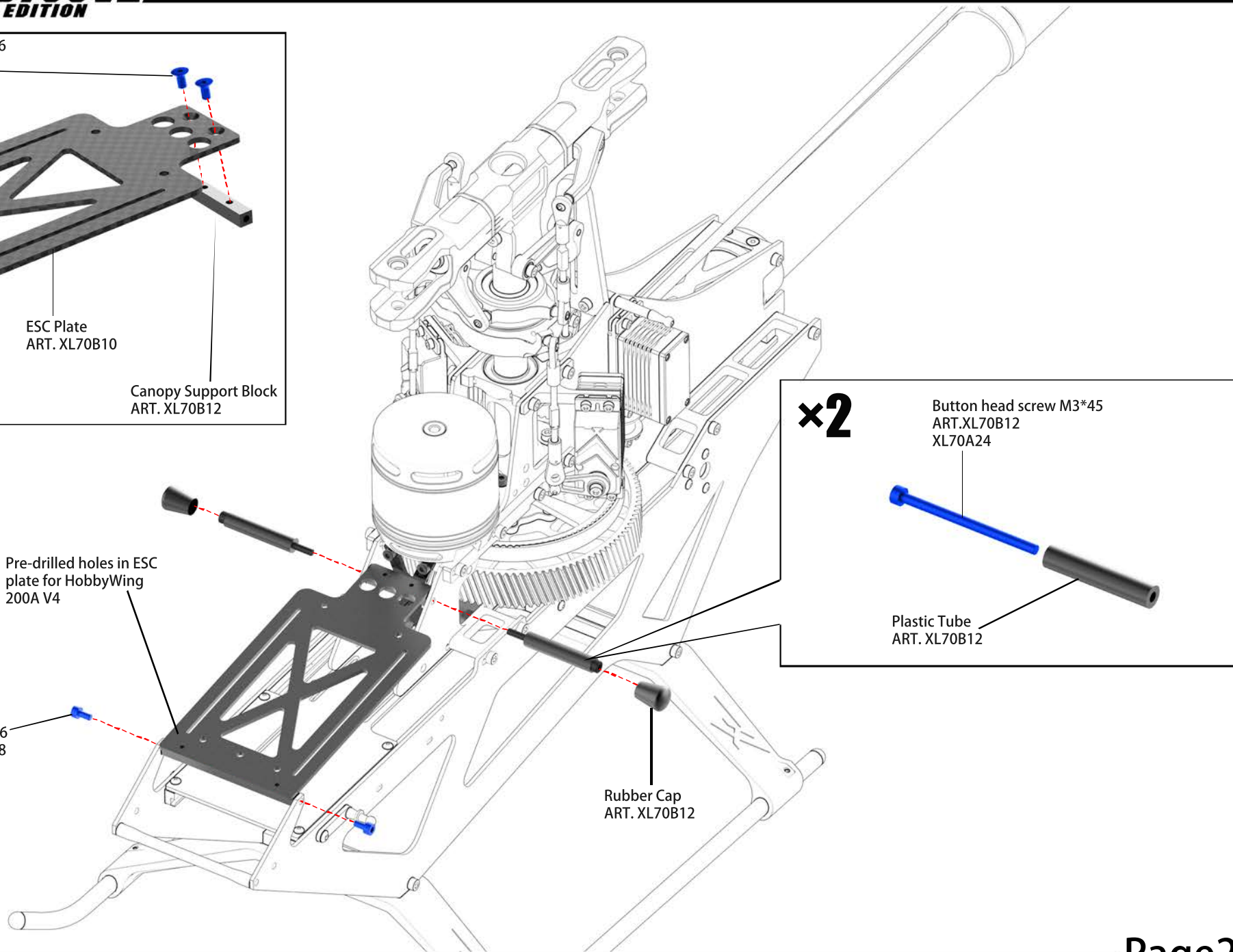
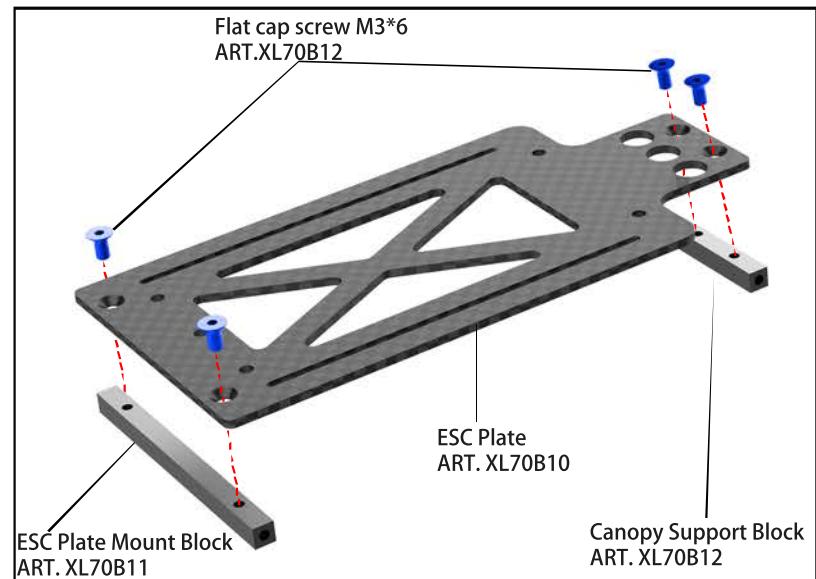

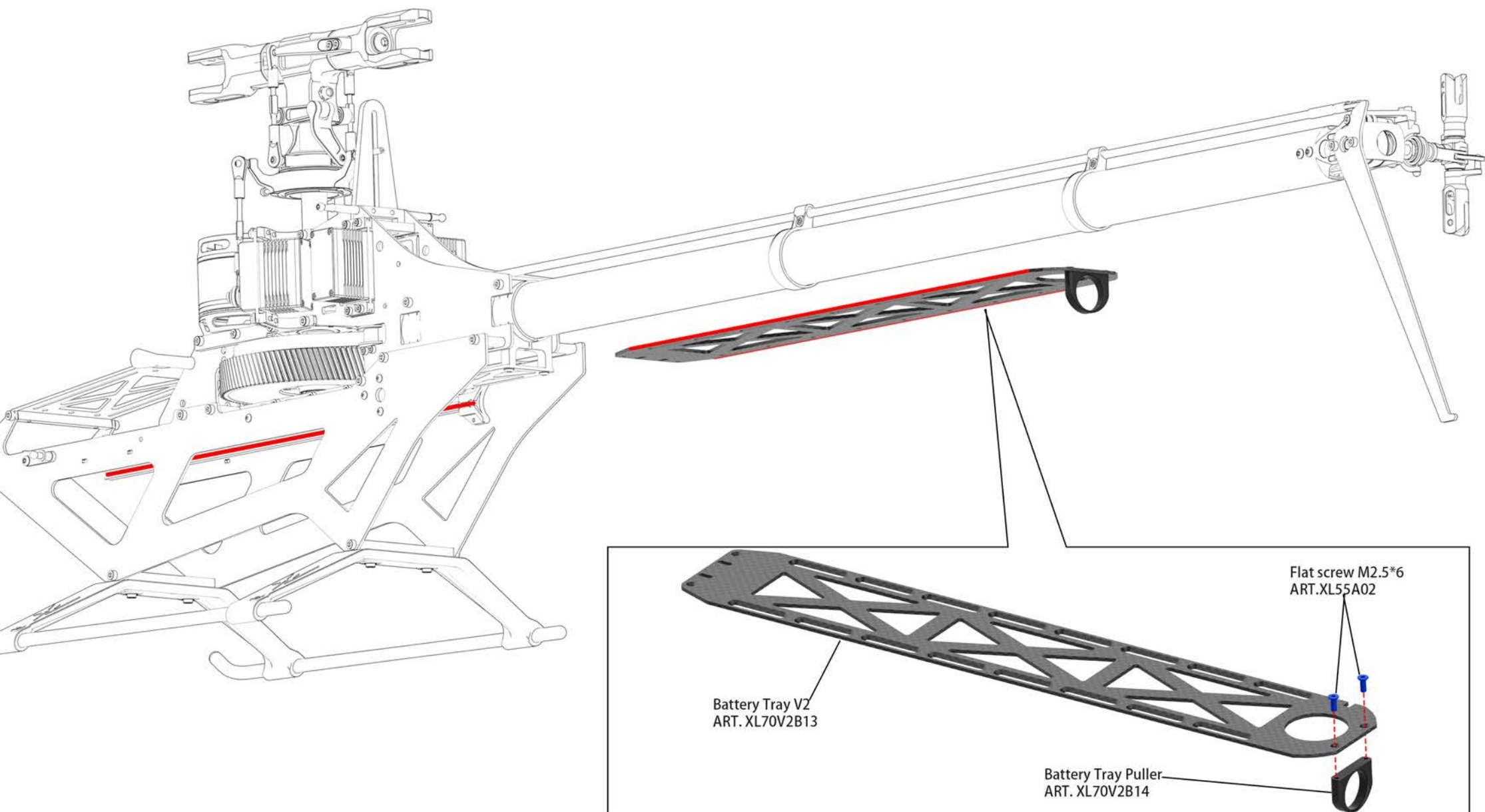



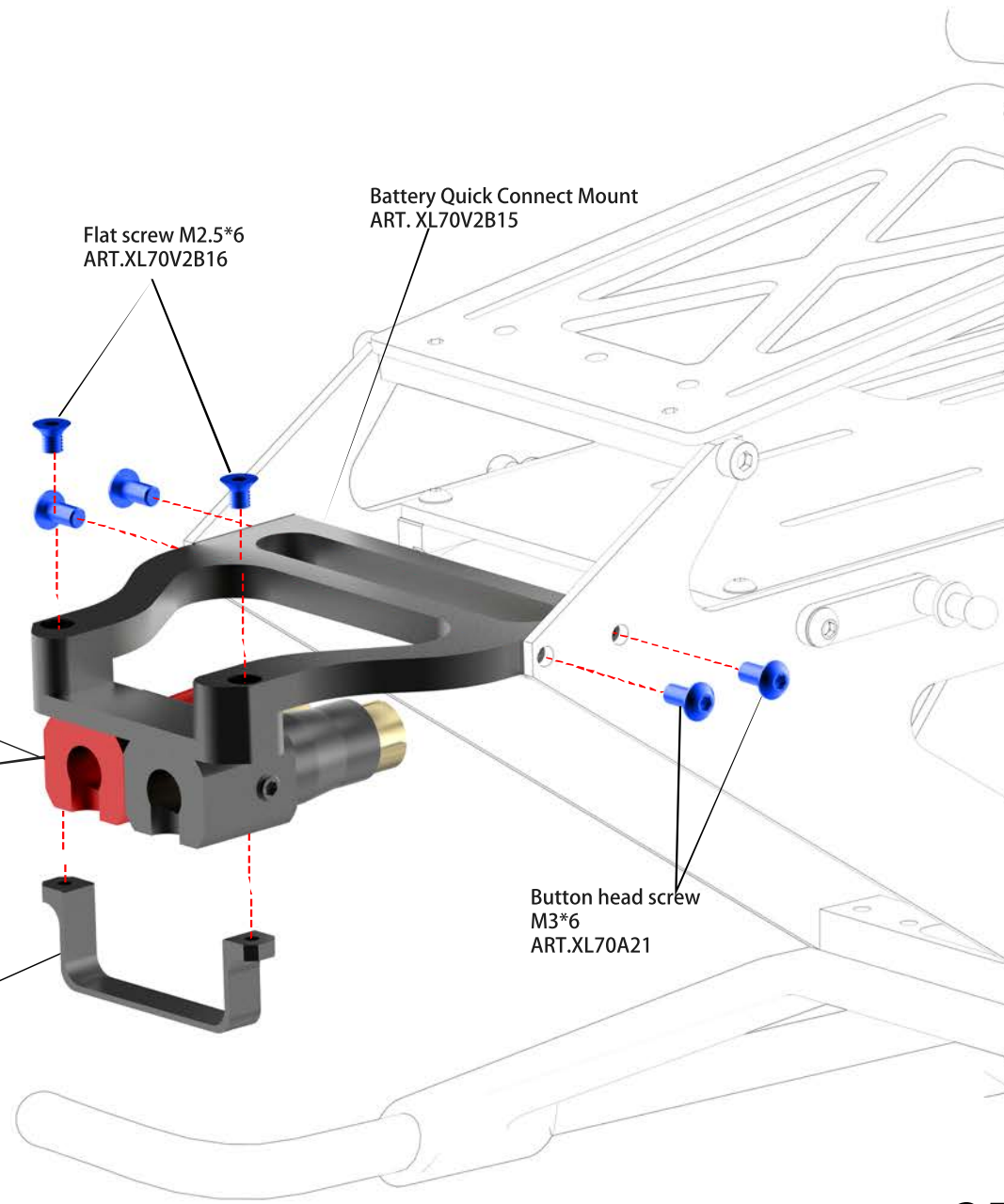
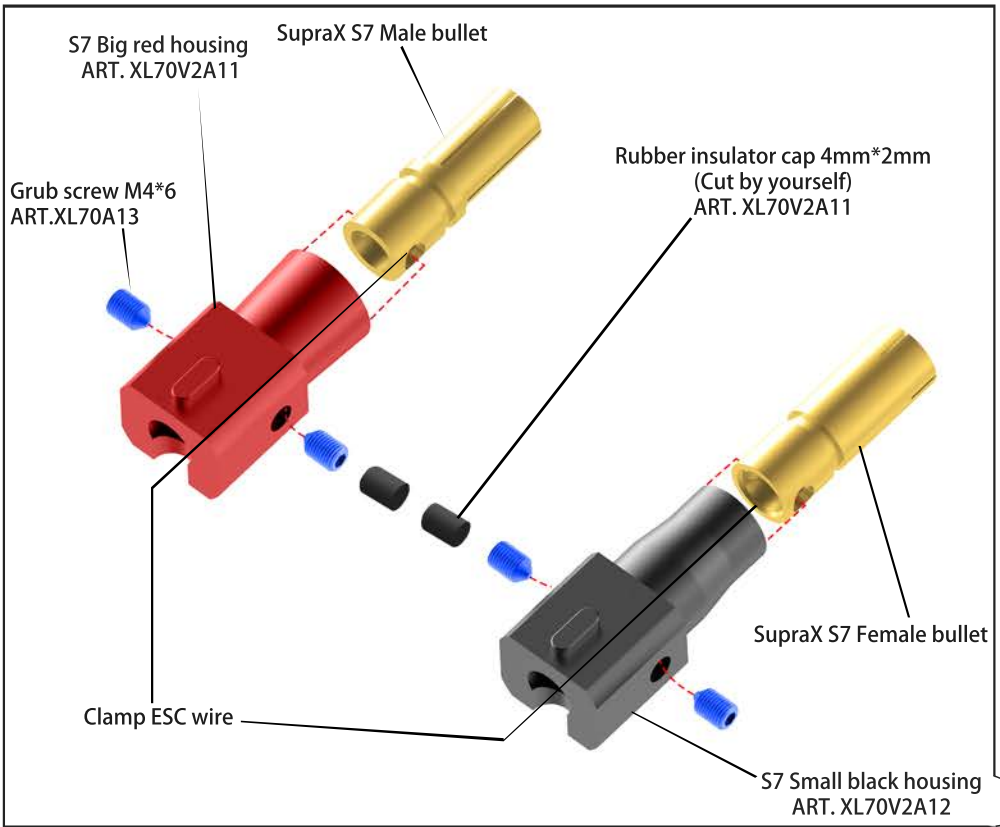

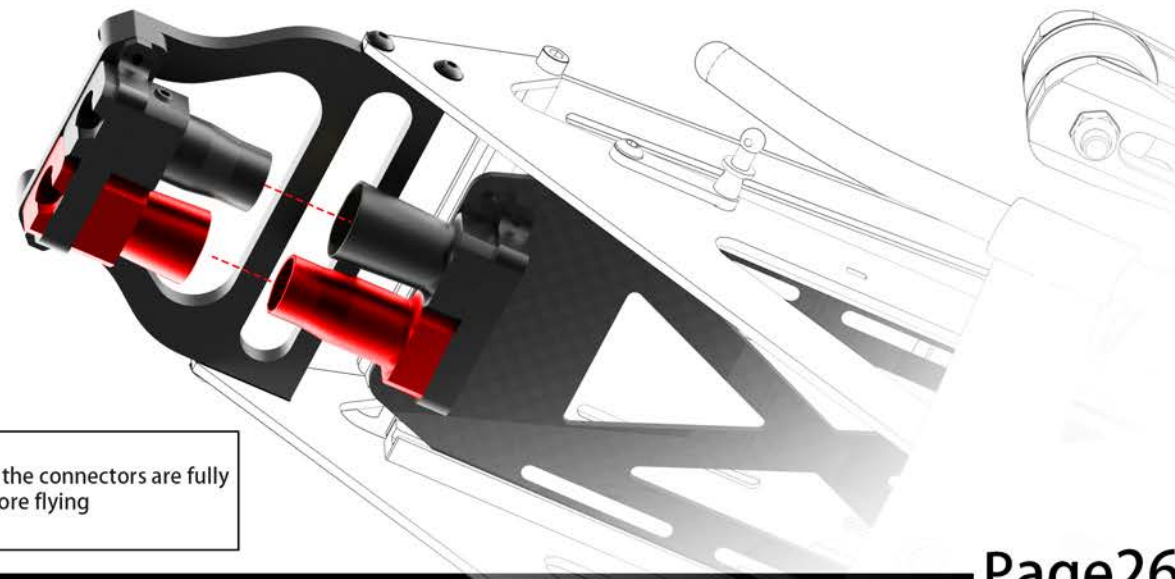
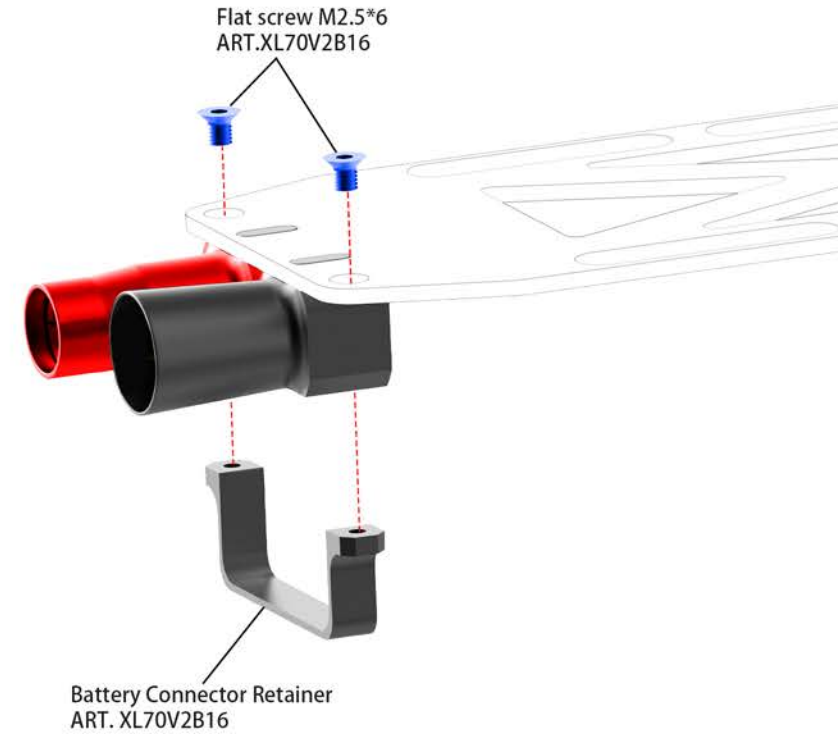
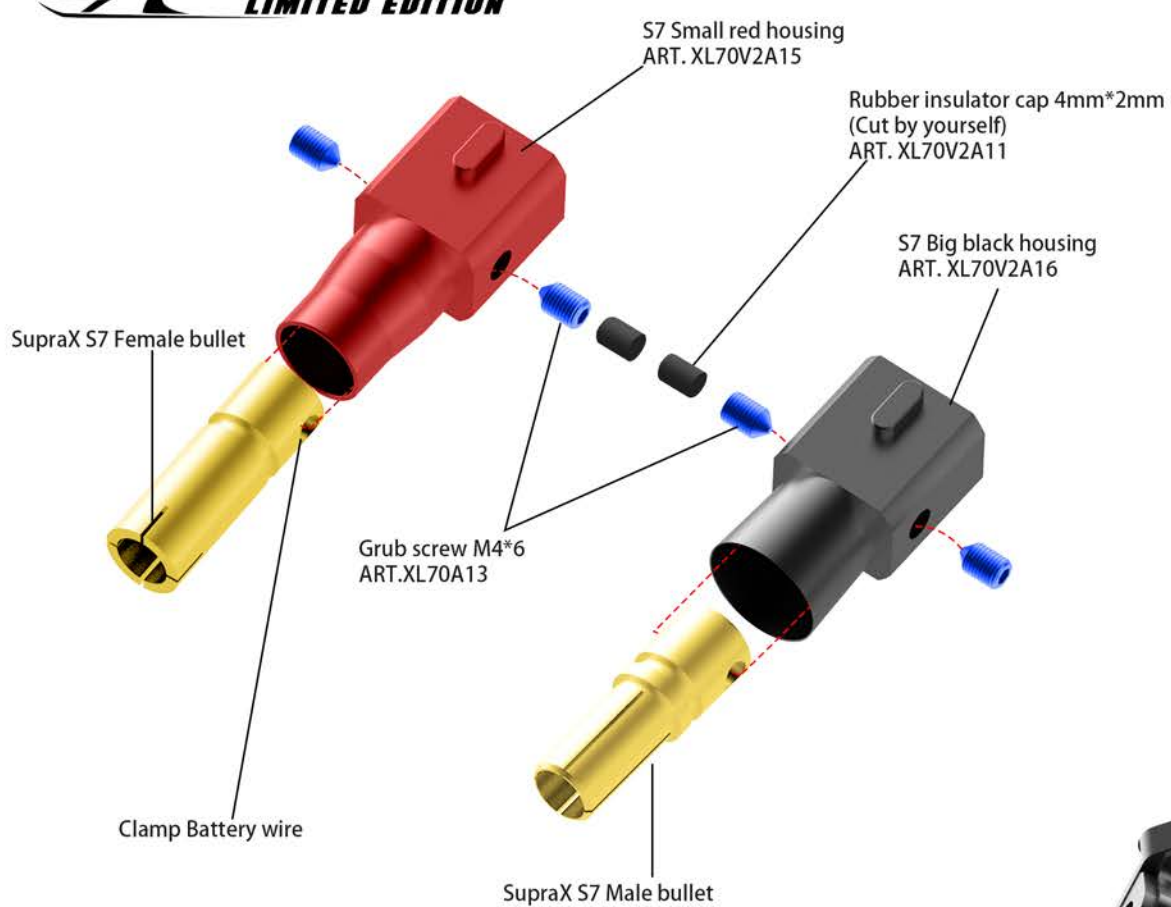



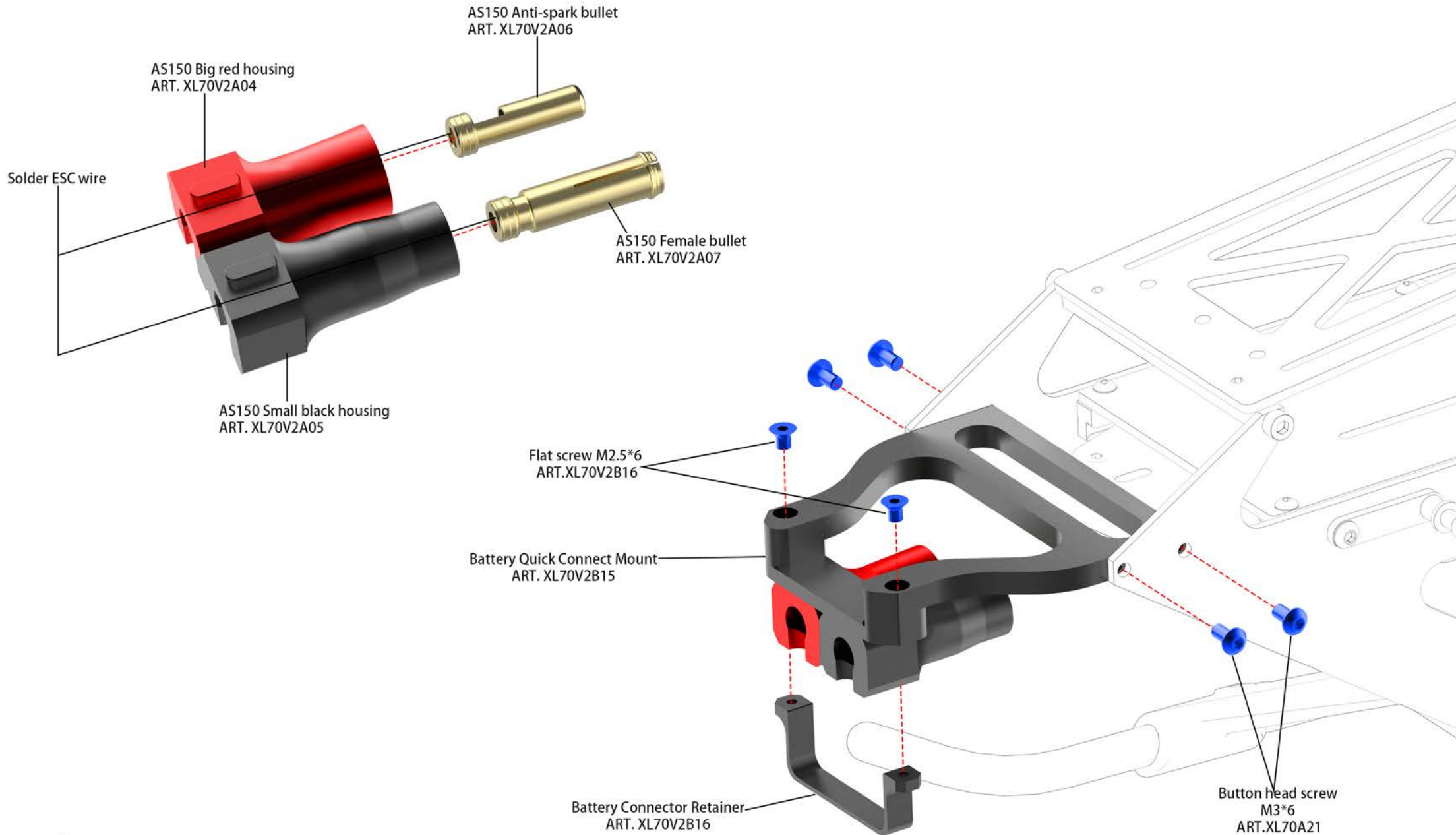

 Make sure the connectors are fully mated before flying

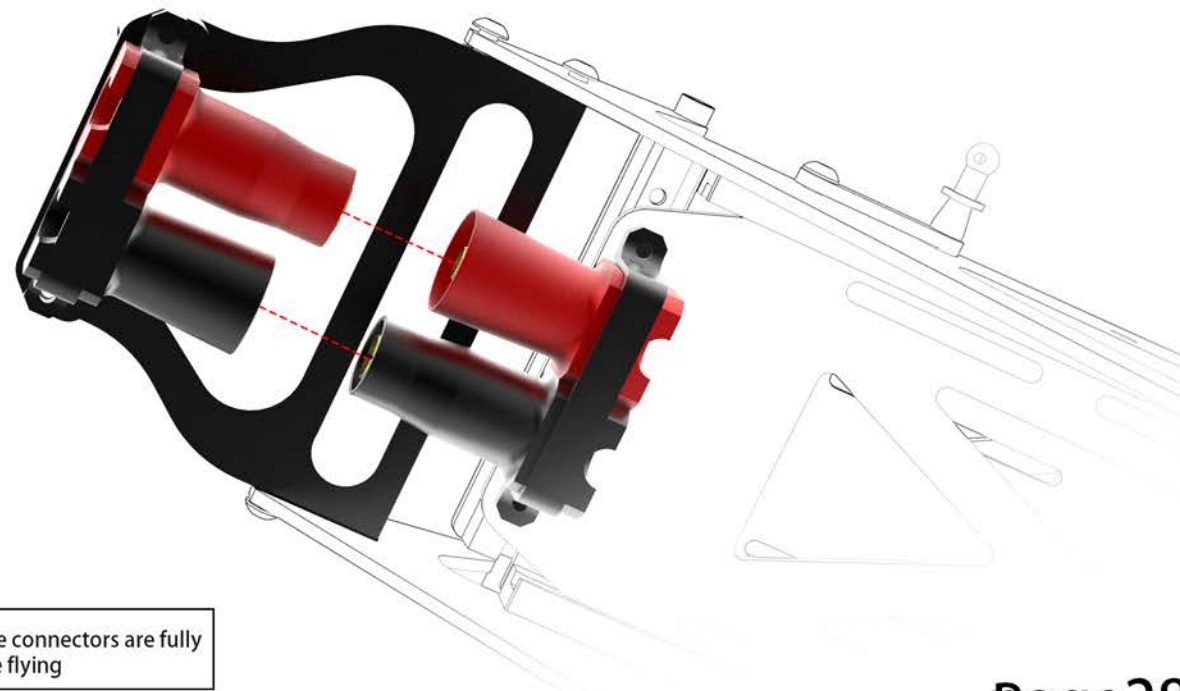
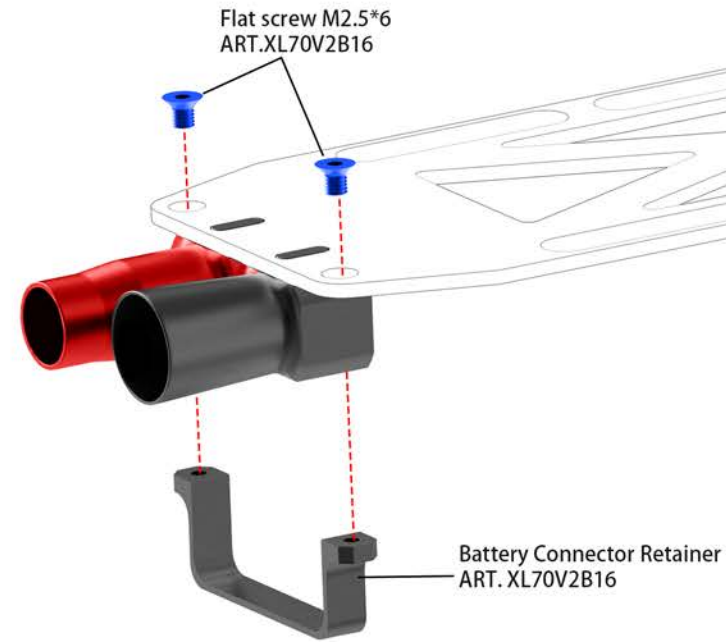
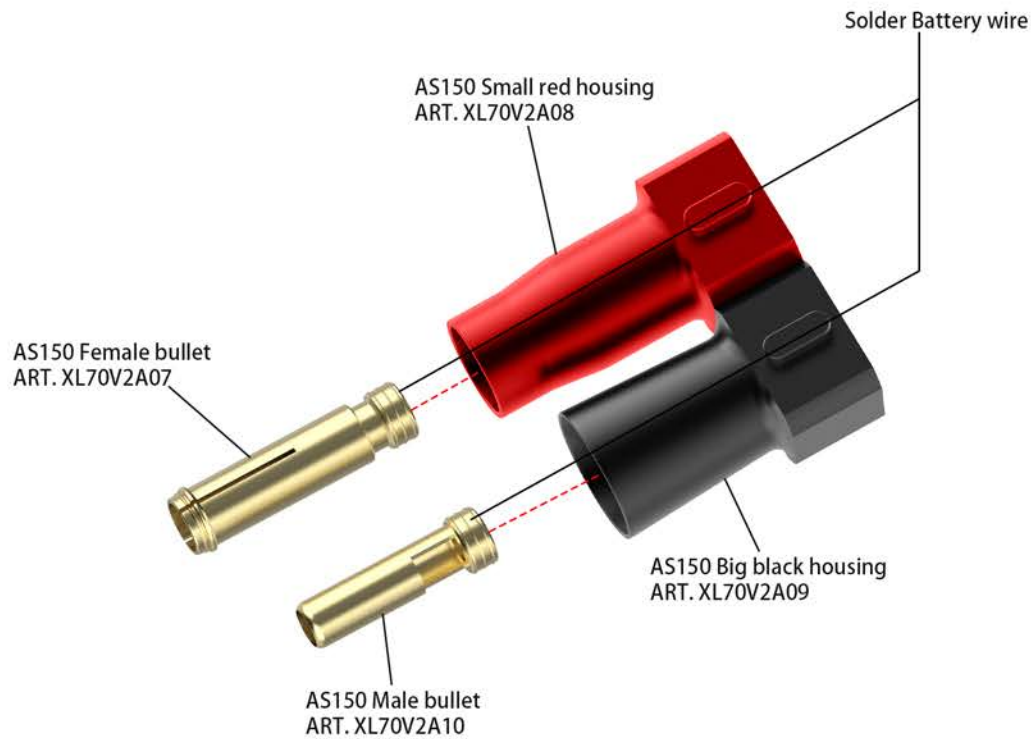



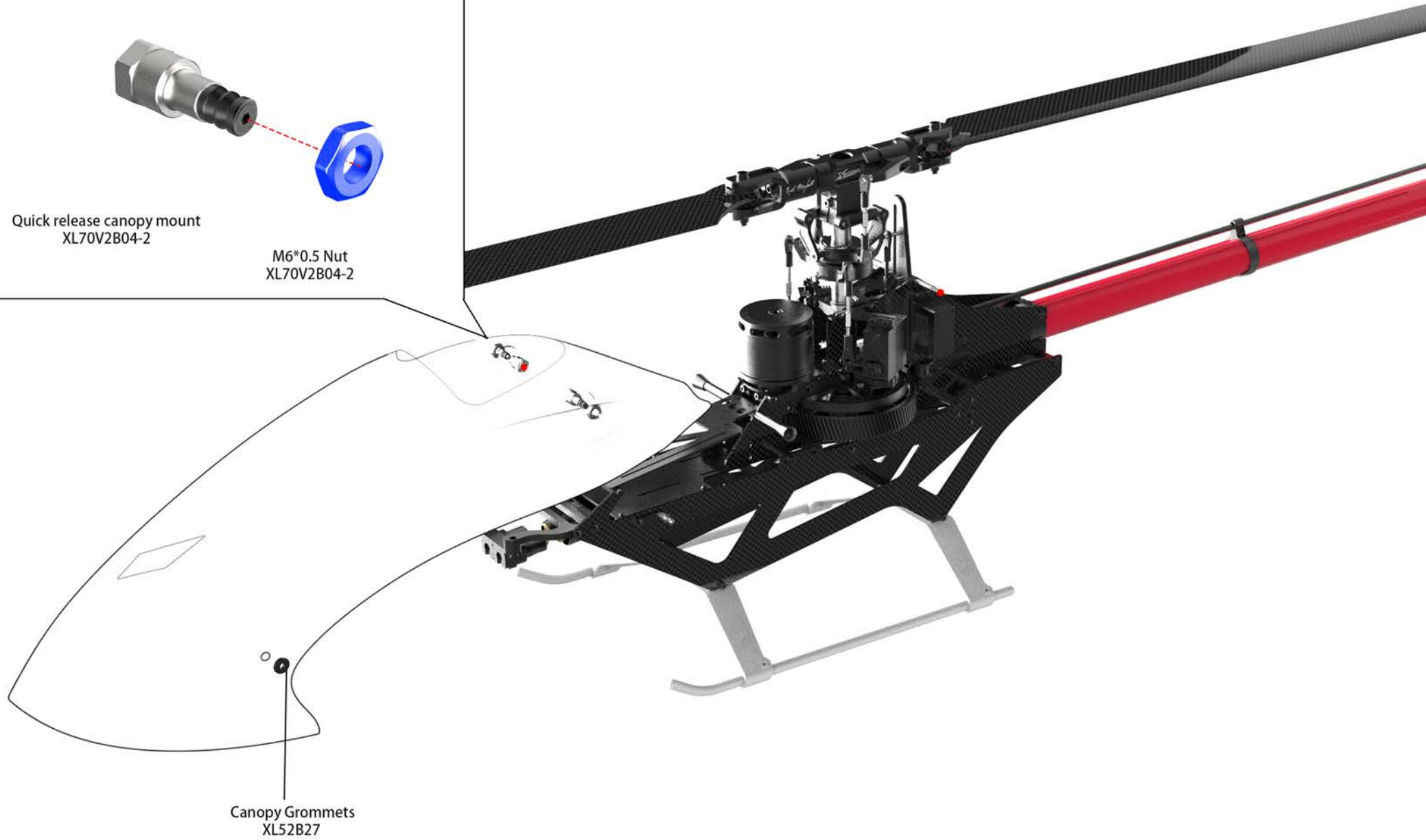
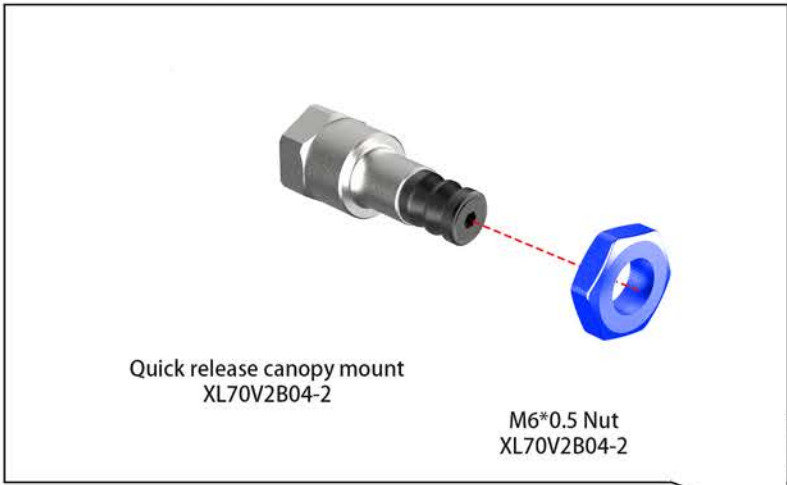

















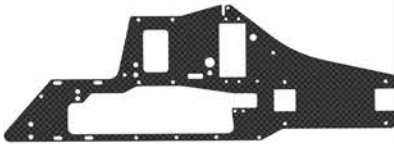















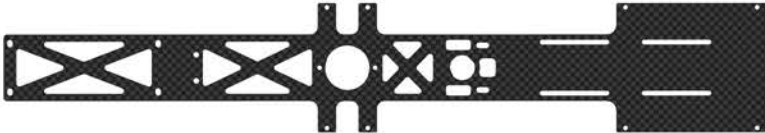
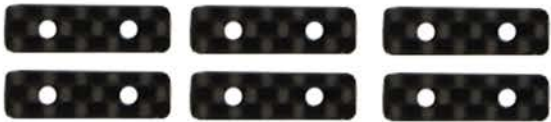

Make sure the connectors are fully mated before flying

















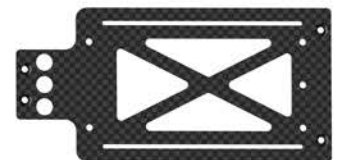



























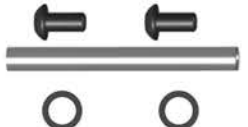

<p><b>MSH71114</b></p>  <p><b>5×Hex screw M3×10</b></p>	<p><b>MSH71108</b></p>  <p><b>5×Hex screw M3×6</b></p>	<p><b>MSH71109</b></p>  <p><b>5×Hex screw M3×8</b></p>	<p><b>MSH71110</b></p>  <p><b>10×Hex screw M2.5×6</b></p>	<p><b>XL70A21</b></p>  <p><b>5×Button head screw M3×6</b></p>	<p><b>XL70V2A03</b></p>  <p><b>5×Button head screw M2.5×6</b></p>	<p><b>XL70B27-1</b></p>  <p><b>10×Hex screw M2.5×4</b></p>
<p><b>XL70B09-1</b></p>  <p><b>10×Hex screw M3×25</b></p>	<p><b>XL70A24</b></p>  <p><b>5×Button head screw M3×45</b></p>	<p><b>MSH71110</b></p>  <p><b>10×Hex screw M2.5×6</b></p>	<p><b>MSH71115</b></p>  <p><b>5×Socket head cap screw M3×30</b></p>	<p><b>MSH41128</b></p>  <p><b>5×Hex screw M2×8</b></p>	<p><b>MSH71101</b></p>  <p><b>5×Flat head screw M4×10</b></p>	<p><b>MSH71116</b></p>  <p><b>5×Hex screw M4×10</b></p>
<p><b>XL70A25-1</b></p>  <p><b>5×Silver Flat screw M3×6</b></p>	<p><b>MSH71116</b></p>  <p><b>5×Hex screw M4×10</b></p>	<p><b>MSH71122</b></p>  <p><b>5×Grub screw M4×4</b></p>	<p><b>XL70H04</b></p>  <p><b>Double Row Angular Contact Bearing 10×19×7</b></p>	<p><b>XL70H05</b></p>  <p><b>2×F10-18M Thrust Bearing 10×18×5.5 2×Washer 10×16×1</b></p>	<p><b>XL70H02-3</b></p>  <p><b>2×Head Damper 4×80°Oring</b></p>	
<p><b>XL70H02-4</b></p>  <p><b>2×Pom damper 2×70°Oring</b></p>	<p><b>XL70H07</b></p>  <p><b>2×Washer 6×15×2 1×Feathering Screw 2×Screw M6×12</b></p>	<p><b>M2 Nut</b></p>  <p><b>MSH41119</b></p>	<p><b>XL70H01-1B</b></p>  <p><b>1×Main Rotor Hub NME 1×Screw M4×25 1×M4 Nut</b></p>		<p><b>MSH71112</b></p>  <p><b>5×Socket head cap screw M3×14</b></p>	<p><b>XL70B13-2</b></p>  <p><b>1×Pom Anti-Rotation Bracket 2×Hex screw M3×6</b></p>
<p><b>XL76H02B</b></p>  <p><b>1×Main Blade Grip Specyter V2 NME 2×Hex screw M3×10</b></p>	<p><b>XL76H04</b></p>  <p><b>3×Screw M4×25 1× M4 Nut 1×Wraith E F3C / Specter V2 Main Shaft</b></p>	<p><b>XL70B03</b></p>  <p><b>1×Upper Servo Mount</b></p>	<p><b>XL70A01</b></p>  <p><b>3×mm Ball 5×7.3 2×Ball 4.72×13.6 mm 3×Ball 5×10.6mm 1×Ball 4.72×8.2mm 1×Ball 5×26.6mm</b></p>			

<p><b>XL70H11B-1</b></p>  <p><b>1×Swashplate Assembly NME V2</b></p>	<p><b>XL70H11-2B</b></p>  <p><b>1×Swashplate (Outer) NME 2×5mm Ball M3×3 1×5mm Ball M3×26</b></p>	<p><b>XL70H11-1BV2</b></p>  <p><b>1×Swashplate (Upper) NME V2 4×5mm Ball M3×3</b></p>	<p><b>XL70H09B</b></p>  <p><b>1×Radius Arm 1×Control arm NME 4×Ball Bearing 3×7×3 1×Screw M3×25 1×Pin 3×14 3×Spacer 3×5×0.5</b></p>	
<p><b>XL70H10</b></p>  <p><b>2×Radius Arm</b></p>	<p><b>XL52A12</b></p>  <p><b>4×MR683ZZ Bearing</b></p>	<p><b>XL70H14</b></p>  <p><b>2×Titanium Servo linkage 4×Ball link</b></p>	<p><b>XL70H14-1</b></p>  <p><b>2×Titanium Main rotor linkage 4×Ball link</b></p>	
<p><b>XL70H14-1</b></p>  <p><b>2×Titanium Main rotor linkage 4×Ball link</b></p>	<p><b>XL70V2NB01-1</b></p>  <p><b>4×Hex screw M3×8 4×Hex screw M3×6 2×Hex screw M3×10 1×Main Shaft Bearing Block WC</b></p>	<p><b>XL70A28</b></p>  <p><b>1×GE15C Bearing 4×POM sleeve</b></p>	<p><b>XL70V2A01</b></p>  <p><b>1×6803ZZ Bearing 17×26×5</b></p>	<p><b>XL70V2B02</b></p>  <p><b>1×Main Shaft Bearing Spacer</b></p>
<p><b>XL70V2B03</b></p>  <p><b>1×Carbon Fiber Upper Frame V2</b></p>	<p><b>XL70V2B01</b></p>  <p><b>1×Third Bearing Block V2 6×Hex screw M3×6 2×Hex screw M3×25 2×Hex screw M2.5×6 2×Button head screw M3×6</b></p>	<p><b>XL70B04</b></p>  <p><b>1×Lower Servo Mount (R)</b></p>	<p><b>XL70B04-1</b></p>  <p><b>1×Lower Servo Mount (L)</b></p>	
<p><b>XL70B13-3</b></p>  <p><b>2×Hex screw M3×6 2×Hex screw M2.5×16 2×Set screw M3×12 2×Hex Screw M2.5×10 1×Anti-Rotation Bracket Mount WC</b></p>	<p><b>XL70V2B04-1</b></p>  <p><b>2×Canopy Mount (Rear) 2×Alu spacer</b></p>	<p><b>XL52A19</b></p>  <p><b>4×Servo Horn For</b></p>	<p><b>XL70V2B05-1</b></p>  <p><b>1×Tail Boom Clmp nitro 1×Flat screw M3×4 1×Flat screw M3×6 4×Hex screw M3×6 1×Hex screw M3×16 1×Hex screw M3×35</b></p>	

<p><b>XL70V2B07</b></p>  <p>1×Carbon Fiber Plate</p>	<p><b>XL70A20</b></p>  <p>2×Ball bearing 3×9×4</p>	<p><b>XL70V2B06</b></p>  <p>2×Pulley 2×pin 3×17 4×Bearing 3×9×4 1×Front belt idler mount upper</p>	<p><b>XL70V2B06-1</b></p>  <p>4×M2.5×6 Screw 2×M2.5×10 Screw 2×M2.5×16Screw 1×Front Belt Idler Mount V2 (Upper)</p>
<p><b>XL70A04</b></p>  <p>3×18mm metal servo horn 3×M2.5 ball 5mm</p>	<p><b>MSH41119</b></p>  <p>10×M2 Nut</p>	<p><b>XL70V2B08</b></p>  <p>1×Center Plate V2</p>	<p><b>XL70V2A02</b></p>  <p>6×Carbon Servo Washer</p>
<p><b>XL70A26</b></p>  <p>4×Ball 5mm M2</p>	<p><b>XL70V2B10</b></p>  <p>1×Lower Carbon Frame V2</p>	<p><b>XL70B27</b></p>  <p>1×Battery Tray Rail (L)</p>	<p><b>MSH71032</b></p>  <p>4×Carbon Servo Washer 8×Hex Screw M2.5×10</p>
<p><b>XL70B28</b></p>  <p>1×Battery Tray Rail (R)</p>	<p><b>XL70B39</b></p>  <p>2×Aluminum Frame Spacer</p>	<p><b>XL70V2B09</b></p>  <p>1×Battery Tray Guide (L) 2×Screw M2.5×6</p>	<p><b>XL70V2B09-1</b></p>  <p>1×Battery Tray Guide (R) 2×Screw M2.5×6</p>
<p><b>XL70V2B17</b></p>  <p>1×Rear frame Spacer</p>	<p><b>XL70B32</b></p>  <p>2×Flat Head Cap Screw 1×Frame Mounting Block 2×Hex screw M3×10 2×Hex screw M3×6</p>		



<p><b>XL70B34-3</b></p>  <p><b>2×Landing Gear Strut</b> <b>4×M3×3mm Set Screw</b></p>	<p><b>XL70B09-2</b></p>  <p><b>2×Motor Mount Brace</b></p>	<p><b>XL70B12</b></p>  <p><b>2×Screw M3×45mm</b> <b>1×ESC mount</b> <b>2×Rubber</b> <b>2×M3×6mm Flat Head Cap Screw</b></p>	 <p><b>2×Flat cap screw M3'6</b></p>	
<p><b>XL70V2B13</b></p>  <p><b>1×Battery tray V2</b></p>	<p><b>XL70B11</b></p>  <p><b>2×M3×6mm Screw</b> <b>2×M3×6mm Flat Haed cap screw</b> <b>1×ESC Mount</b></p>	<p><b>XL70B10</b></p>  <p><b>1×ESC Plate</b></p>	<p><b>XL70V2B14</b></p>  <p><b>1×Battery Tray Puller</b> <b>2×Flat screw M2.5×6</b></p>	
<p><b>XL70A06</b></p>  <p><b>2×F686zz Bearing</b></p>	<p><b>XL70V2T11B-1</b></p>  <p><b>1×tail pitch Lever Support</b> <b>1×M3×8 screw</b></p>	<p><b>XL70M01</b></p>  <p><b>1×4525 Motor</b></p>	<p><b>XL70B05-1</b></p>  <p><b>2×Motor Mount V2</b> <b>2×Hex screw M3x6</b> <b>4×Hex screw M4x10</b></p>	<p><b>XL70B08</b></p>  <p><b>1×X-Carbon Fiber Brace</b></p>
<p><b>XL70T13-2</b></p>  <p><b>1×Tapered End Tail Shaft</b> <b>1×M4×10 Flat head screw</b></p>	<p><b>XL70V2T01-R</b></p>  <p><b>1×Tail Boom V2-R</b></p>	<p><b>XL70V2T02B-1</b></p>  <p><b>1×Ultra light tail case</b> ↑↑ ↑↑ <b>2×M3×6 screw</b> <b>4×M3×6Button head screw</b> <b>1×M3×30 screw</b></p>	<p><b>XL70V2T04</b></p>  <p><b>1×21T tail pulley</b> <b>1×M4×4Set screw</b></p>	<p><b>XL70V2T04-1</b></p>  <p><b>1×20T tail pulley</b> <b>1×M4×4Set screw</b></p>
		<p><b>XL70A06-1</b></p>  <p><b>2×Ball bearing 6×13×5</b></p>	<p><b>XL70V2NT03</b></p>  <p><b>2×Rear Belt Idler Spacer</b> <b>2×Bearing 3×8×3</b> <b>1×Washer3×6×1</b></p>	<p><b>XL52A12</b></p>  <p><b>4×MR683ZZ Bearing</b></p>

<p><b>XL70V2T05-2</b></p>  <p>1×Vertical Fin</p>	<p><b>XL70T12-2</b></p>  <p>1×Tail Pitch Slider 2×MF128 Bearing</p>	<p><b>XL70T12-1</b></p>  <p>1×Tail Shaft Slide Bushing</p>	<p><b>XL52T11</b></p>  <p>2×Tail Control Link</p>	 <p>2×Pitch Slider Fork Bushing 2×3×3</p>
<p><b>XL70T12-4</b></p>  <p>1×Tail pitch slider 2×Hex screw M2×8 2×Ball 4.72mm</p>	<p><b>XL52T09-2</b></p>  <p>2×screw M2.5×6</p>	<p><b>XL70A22</b></p>  <p>2×F683zz Bearing 3×7×3</p>	<p><b>XL70T09B</b></p>  <p>1×Tail Pitch Lever NME 2×M2.5×6 screw 2×Bearing 3×7×3 Flange 2×M2.5×6 Pitch lever screw</p>	<p><b>XL70V2T07B-1</b></p>  <p>1×Tail Pitch Control Arm nitro 2×M2.5×6 screw 1×5mm ball</p>
<p><b>XL70T14-3</b></p>  <p>2×Center pin 2×Washer M2×4 2×Hex screw M2×3 2×F 683zz Ball Bearing 3×7×3 Flanged</p>	<p><b>XL70T15-1</b></p>  <p>4×O ring for tail shaft 2×Washer 5×8×0.5</p>	<p><b>XL70T20</b></p>  <p>2×Hex screw M4×6 2×M4 Washer 1×Tail Spindle</p>	<p><b>XL70A27</b></p>  <p>5×Washer 5×7×0.3</p>	 <p>1×Thrust Bearing 5×10×4</p>
<p><b>XL70T17</b></p>  <p>4×Ball bearing 5×10×4</p>	<p><b>XL70T14-2</b></p>  <p>1×Tail Center Hub WC</p>	<p><b>XL70T16B</b></p>  <p>1×Tail grip NME 1×M3×17 Screw 1×M3 Nut 1×4.72 mm ball 2×Bearing 5×10×4</p>		<p><b>XL70B21-3</b></p>  <p>2×6702zz Ball bearing 15×21×4</p>
<p><b>XL70V2T03</b></p>  <p>1×8mm Tail Belt V2</p>	<p><b>XL70V2B21</b></p>  <p>1×Upper one way hud 1×Lower one way hub 2×Bearing 15×21×4 6×M3×12 Screw</p>	<p><b>XL70B21-1</b></p>  <p>1×One way bearing</p>	<p><b>XL70V2B11</b></p>  <p>1×118mm Heavy Duty Main Gear 106T Mod1 V2</p>	<p><b>XL70V2B12</b></p>  <p>1×100T Front Pulley 1×M4×25 screw</p>

<p><b>XL70H13-1</b></p> <p>1×Main shaft collar 1×M3×12 Screw 1×M4×4 Set screw</p>	<p><b>XL70A23</b></p> <p>5×Hex screw M4×25</p>	<p><b>XL70V2T08-1</b></p> <p>2×Tail pushrod end 2×Tail pushrod end linkage screw 2×Ball Link 5mm M3 1×Ball 5mm M3*3 1×Ball 5mm M2*4.8</p>	<p><b>XL70A02</b></p> <p>8×Ball Link</p>	<p><b>XL70V2T08-2</b></p> <p>1×Tail Control Rod NME</p>
<p><b>XL70V2T09</b></p> <p>2×Tail control rod guide 2×M2×Screw 2×M2×Nut</p>	<p><b>XL70G11</b></p> <p>1×Motor Pinion 2×M4*4mm Set Screw</p>	<p><b>XL70A16</b></p> <p>2×688ZZ Ball Bearing 8×16×5</p>	<p><b>XL70B12</b></p> <p>2×Rubber 2×M3×45mm screw 1×Plastic Tube 2×ESC mount 2×M3×6mm Flat Head Cap Screw</p>	
<p><b>XL70V2A04</b></p> <p>4×AS150 Big red housing</p>	<p><b>XL70V2A06</b></p> <p>2×AS150 Anti-spark bullet</p>	<p><b>XL70V2A07</b></p> <p>4×AS150 Female bullet</p>	<p><b>XL70V2A05</b></p> <p>4×AS150 Small black housing</p>	<p><b>XL70V2B16</b></p> <p>1×Battery Connector Retainer 2×Flat screw M2.5×6</p>
<p><b>XL70V2B15</b></p> <p>1×Battery Quick Connect Mount 4×Button head screw M3×6</p>	<p><b>XL70V2A08</b></p> <p>4×AS150 Small red housing</p>	<p><b>XL70V2A09</b></p> <p>4×AS150 Big black housing</p>	<p><b>XL70V2A10</b></p> <p>4×AS150 Male bullet</p>	<p><b>XL70V2A11</b></p> <p>4×S7 Big red housing 8×Grub screw M4×6</p>
<p><b>XL70V2A12</b></p> <p>4×S7 Small black housing 8×Grub screw M4×6</p>	<p><b>XL70V2A15</b></p> <p>4×S7 Small red housing 8×Grub screw M4×6</p>	<p><b>XL70V2A16</b></p> <p>4×S7 Big black housing 8×Grub screw M4×6</p>	<p><b>XL70V2B04-2</b></p> <p>2×Quick release canopy mount 2×M6×0.5 Nut</p>	<p><b>XL70A29</b></p> <p>6×Washer 10×16×0.1</p>