

**CLIENT:** HIDEAWAY INCORPORATED  
 8936 146 St.  
 Edmonton, AB  
 T5R 0V9

<b>Test Report No: T1353-8a</b>	<b>Issue Date: July 15, 2022</b>
---------------------------------	----------------------------------

**SAMPLE ID:** Hideaway Inc. Privacy Screens (Branch, Dash, River Rock) systems.

**SAMPLING DETAIL:** Six (6) systems of each style were selected from inventory by QAI representative Glen Harris on March 12, 2020 from Hideaway Inc. location in Edmonton, AB. The systems were confirmed at QAI Toronto to match drawings found in Appendix A to D of this report.

**DATE OF RECEIPT:** Samples were received at QAI on March 20, 2020 in good condition.

**TESTING PERIOD:** March 23 to April 30, 2020.

**AUTHORIZATION:** QAI Proposal Number 19JL05311 dated May 31, 2019 and was signed by TJ Townsend on June 14, 2019.

**TEST(S) REQUESTED:** Testing was conducted to the 2020 National Building Code of Canada (2020 NBC), Section 4.1.5.14 *Loads on Guards*, Sections 3.3.1.18 and 9.8.8.5 for maximum opening size limitations, and Section 9.8.8.6 *Climbability*.

**CONCLUSIONS:** Hideaway Inc. Branch, Dash, and River Rock privacy screen systems, were found to comply with the load requirements of Section 4.1.5.14 of the 2020 NBC.

Hideaway Inc. Branch, Dash, and River Rock assemblies when installed with panels having clearance between bottom of panel and substrate at < 100 mm, comply with Section 3.3.1.18 and 9.8.8.5 of the 2020 NBC.

Hideaway Inc. Branch and River Rock assemblies were found to have openings that do not restrict climbability. These products shall not be installed where protection from a level > 4.2 meters height from an adjacent level exist.

Detailed results can be found on subsequent pages of this report.

**Disclaimer:** This report outlines evaluation of the above-described systems for compliance to the service and factored loads and material specifications as outlined by the above building codes. This report does not constitute site design. Details including load resistance, anchorage connections and other areas as required by the specific site per the applicable code are to be specified by the engineer of record and authority having jurisdiction.

**Prepared By**  
  
 Robert Giona  
 Operations Manager

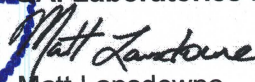
 Signed for and on behalf of  
 M. W. LANSDOWNE QAI Laboratories Ltd.  
  
 Matt Lansdowne  
 VP of Operations

## 1.0 SAMPLE ASSEMBLY AND DESCRIPTION

### COMPONENT DESCRIPTIONS:

All components of Hideaway Inc. Privacy Screens products evaluated by QAI were aluminum, painted.

**Screens:** All screens measured 914 mm (36") wide by 1727 mm (68") high and were 2.54 mm (0.100") thickness.

**Mounting Posts:** All posts were 76mm x 76mm (3" x 3") measuring 1844mm (73") in length. The wall thickness of the posts was measured at 3.175 mm (0.125").

**Post Mounting Plates:** The mounting plate measures 130 mm (5") x 130 mm (5") with a thickness of 9.5 mm (0.375") and were welded to the post with a fillet weld measuring 8.5 mm in both horizontal and vertical dimensions. Each plate has 4 holes drilled for mounting to substrate each hole measured 11 mm (0.433") in diameter and was spaced 97 mm (3.8") from adjacent holes.

**Post Spacing:** Posts are mounted 991 mm (39") on-center spacing to accommodate the screens and mounting brackets.

**Screen Bracket:** Brackets were 25.4 mm (1") L-Brackets made from 3.2 mm (0.175") thick aluminum. Each bracket contained five (5) 7.5 mm (0.313") diameter holes spaced 425 mm (16.625") on-center.

**Finish:** All components were powder coated with either a black or white color finish.

**Fasteners:** As described in Appendix D

### SAMPLE ASSEMBLY

QAI conducted all installation of the test assemblies at QAI Toronto, ON location. Installation of the screen into the system was completed following the provided instructions and hardware provided with each system. Each assembly was constructed using the mounting brackets provided.

To assemble, the posts were spaced 914 mm (36") apart when measured from inside post to inside post. A post cap was inserted into the top of each post, and a mounting bracket was installed onto the post, with the top of the bracket in contact with the post cap. Each bracket was installed so that the front face of the L-bracket was located at the vertical center line of the post, using the 10-24 x 3/4" self-drilling screws provided with the kit. With the brackets installed, the screen was located so that the pre-drilled mounting holes aligned and attached, using the 1/4"-20 x 1/2" machine screws and 1/4"-20 acorn nuts provided with the kit.

During testing, the assembly was oriented to ensure load caused tension in the fasteners / bracket connection, as this load direction was considered "worst case".

The test samples were mounted to a structural steel reaction frame using 9.5 mm (0.375") diameter, 100 mm (4") long Grade 5 stainless steel bolts to ensure failure was localized to the Hideaway Inc. test assemblies.

This evaluation did not consider anchorage of post to substrate for field application and evaluated the Hideaway Privacy Screen systems load resistance only.

## **2.0 TEST PROCEDURE:**

Testing was conducted in accordance with the following requirements from the 2020 NBC Section 4.1.5.14:

The guard is required to be loaded at a rate to achieve the specified loads between 10 seconds and 5 minutes. The specified loads below are then held for one minute before the load is released. As per the 2020 National Building Code of Canada (2020 NBC) – section 4.1.5.14 & section 9.8.8.2 “Loads on Guards” the following tests were conducted:

One complete railing system, consisting of two posts, was tested at maximum spacing and height to represent the worst-case scenario.

1. The minimum specified horizontal load applied inward or outward at the minimum required height of every required guard shall be:
  - c) 0.75 kN/m or a concentrated load of 1.0 kN applied at any point so as to produce the most critical effect.<sup>1</sup>
2. The minimum specified horizontal load applied inward at the minimum required height of every required guard shall be half that specified in sentence 1 above.
3. Individual elements within the guard, including solid panels and picket, shall be designed for a load of 0.5 kN applied over an area of 100 mm x 100 mm located at any point in the elements so as to produce the most critical effect.
4. The size of the opening between any two adjacent vertical elements within a guard shall not exceed the limits required by Part 2 when each of the elements is subjected to a specified live load of 0.1 kN applied in the opposite directions in the in-plane direction of the guard so as to produce the most critical effect.
5. The loads required in Sentence (3) need not be considered to act simultaneously with the loads provided for in Sentences (1), (2) and (6).
6. The minimum specified load applied vertically at the top of every required guard shall be 1.5 kN/m and need not be considered to act simultaneously with the horizontal load provided for in sentence (1).

**Note 1:** Clauses (a) and (b) of Section 4.1.5.14 of 2020 NBC were not considered appropriate applications of Hideaway Inc. products and were not evaluated by QAI as these products are not intended for areas of means of egress and for equipment access walkways.

Testing was conducted by evaluation of a Hideaway post to determine failure mode of the aluminum component to determine brittle or ductile failure for determination of the Performance Factor. Based on evaluation of the post including welds at anchor connections, it was determined the failure mode was brittle, as such, an aluminum performance factor of 0.75 was applied per CAN/CSA S157/S157.1 *Strength Design in Aluminum*. Applied loads were adjusted to 1.5 with an applied performance factor of 0.75 = 2.0 adjustment.

Testing was conducted on minimum 2 assemblies to show consistency of results.

**TEST REQUIREMENTS:**

2020 NBC Section 4.1.5.14:

LOAD TYPE	LOCATION	2020 NBC LOAD	PERFORMANCE FACTOR $\phi$	TOTAL LOAD	REQUIREMENT
Concentrated Load	Panel	1.0 kN (225 lbs)	0.75	2.0 kN (450 lbs)	Cannot fail, recover after load release
	Connection				
	Post				
Horizontal Line Load*	Top Rail	0.75 kN/m (51.4 lbs/ft)	0.75	1.50 kN/m (102.3 lbs/ft)	Cannot fail, recover after load release
In-Fill Load 100 mm x 100 mm	Panel	0.5 kN (113 lbs)	0.75	1.0 kN (225 lbs)	Cannot fail, recover after load release
Vertical Line Load	Top Rail	1.5 kN/m (450 lbs/ft)	0.75	3.0 kN/m (206 lbs/ft)	Cannot fail, recover after load release
Horizontal Deflection	Post	1.0 kN (225 lbs)	0.75	N/A	$\leq 3.5''$
Horizontal Deflection	Top Rail, Mid-Span	1.0 kN (225 lbs)	0.75	N/A	$\leq 2.125''$
Vertical Deflection	Top Rail, Mid-Span	1.5 kN/m (450 lbs/ft)	0.75	N/A	$\leq 0.375''$

2020 NBC Section 9.8.8.3: Guards shall be a minimum of 1070 mm (42 inches) height.

2020 NBC Section 9.8.8.5: Openings shall resist passage of spherical object of 100 mm diameter.

2020 NBC Section 9.8.8.6: Where guards are required to protect a level located more than 4.2 m above the adjacent level the guard shall not have openings that facilitate climbing per Note A9.8.8.6(1c) (defined as protrusions < 450 mm spacing apart, > 45 mm wide x 20 mm high).

\*As the screen span is 914mm (36"), the 1.0 kN (225 lbs) concentrated load governs (is greater) than the 0.75 kN/m (51.4 lbs/ft x 3 ft = 154 lbf) total horizontally distributed load applied at quarter-points).





**TEST RESULTS:**

The following summarizes testing to 2020 NBC for Hideaway Inc. Privacy Screen products evaluated by QAI.

**2020 NBC EVALUATION FOR HIDEAWAY PRIVACY SCREENS - DASH**

Test		Service Loads		Deflection		Allowable Deflection at Load	Observations at Service Load	Factored Loads		Deflection		Observations at Factored Load
				At Service Load	Residual					At Factored Load	Residual	
Concentrated Horizontal Load	Top of Post	1.0 kN	225 lbf	1.30" (33mm)	0.0" (0mm)	3.5" (89mm)	Deflection within allowable. Negligible permanent set.	2.0 kN	450 lbf	5.63" (143mm)	0.24" (6mm)	Factored Load Held.
	Mid-Span of Top Rail			<b>4.02"<sup>6</sup></b> <b>(102mm)</b>	0.16" (4mm)	2.125" (54mm)	Deflection <b>exceeds<sup>6</sup></b> allowable. Negligible permanent set.			6.42" (163mm)	1.02" (26mm)	Factored Load Held.
	End of Top Rail at Post			1.34" (34mm)	0.0" (0mm)	3.5" (89mm)	Deflection within allowable. Negligible permanent set.			3.35" (85mm)	0.51" (13mm)	Factored Load Held.
Horizontal – Uniform Load		0.75 kN/m	51.4 lbf/ft	1.18" (30mm)	0.04" (1mm)	3.5" (89mm)	Deflection within allowable. Negligible permanent set.	1.5 kN	675 lbf	1.34" (34mm)	0.04" (1mm)	Factored Load Held.
Vertical – Uniform Load		1.5 kN/m	103 lbf/ft	0.0" (0mm)	0.0" (0mm)	0.75" (19mm)	Deflection within allowable. Negligible permanent set.	3.0 kN/m	206 lbf/ft	0.0" (0mm)	0.0" (0mm)	Factored Load Held.
In-Fill Load	Mid-Height of Picket	0.5 kN	113 lbf	3.07" (78mm)	0.31" (8mm)	n/a	Withstood service loads.	1.0 kN	225 lbf	3.27" (83mm)	0.16" (4mm)	Factored Load Held.
Equivalent Horizontal Uniform Load at Intermediate Post		1.37 kN	308 lbf	--	--	3.5" (89mm)	See Note Below.	2.74 kN	617 lbf	1.97" (50mm)	0.16" (4mm)	Factored Load Held.

NOTE: Equivalent Horizontal Uniform Load at Intermediate Post was tested to measure load achieved at 50 mm deflection in lieu of measuring the deflection at required load. It is safe to assume that the deflection criteria at 1.37 kN (308 lbf) was met as the load to achieve 50 mm deflection was 2.73 kN (614 lbf).

**2020 NBC EVALUATION FOR HIDEAWAY DASH PRIVACY SCREENS**

SECTION	LOAD TYPE	LOCATION	REQUIRED	TEST 1	Y/N	TEST 2	Y/N
4.1.5.14	Concentrated Load	Panel	2.0 kN	2.0 kN	Y	2.0 kN	Y
		Connection		2.0 kN	Y	2.0 kN	Y
		Post		2.0 kN	Y	2.0 kN	Y
	Horizontal Line Load	Top Rail	1.5 kN/m	1.5 kN/m	Y	1.5 kN/m	Y
	In-Fill Load 100 mm x 100 mm	Panel	1.0 kN	1.0 kN <sup>2</sup>	Y	1.0 kN <sup>2</sup>	Y
	Vertical Line Load	Top Rail	3.0 kN/m	3.0 kN/m	Y	3.0 kN/m	Y
9.8.8.3	Height of Guards	Top Rail	-	> 1070 mm	Y	> 1070 mm	Y
9.8.8.5	Openings	Any	< 100 mm	≥ 100 mm <sup>3</sup>	N	≥ 100 mm <sup>3</sup>	N
9.8.8.6	Climbability	Any	< 45 x 20 openings	< 45 x 20 <sup>4</sup>	N	< 45 x 20 <sup>4</sup>	N



**2020 NBC EVALUATION FOR HIDEAWAY PRIVACY SCREENS - BRANCH**

Test		Service Loads		Deflection		Allowable Deflection at Load	Observations at Service Load	Factored Loads		Deflection		Observations at Factored Load
				At Service Load	Residual					At Factored Load	Residual	
Concentrated Horizontal Load	Top of Post	1.0 kN	225 lbf	1.54" (39mm)	0.0" (0mm)	3.5" (89mm)	Deflection within allowable. Negligible permanent set.	2.0 kN	450 lbf	6.18" (157mm)	0.24" (6mm)	Factored Load Held.
	Mid-Span of Top Rail			<b>4.76"<sup>6</sup></b> <b>(121mm)</b>	0.16" (4mm)	2.125" (54mm)	Deflection <b>exceeds</b> allowable. Negligible permanent set.			4.92" (125mm)	0.35" (9mm)	Factored Load Held.
	End of Top Rail at Post			1.85" (47mm)	0.16" (4mm)	3.5" (89mm)	Deflection within allowable. Negligible permanent set.			3.19" (81mm)	0.51" (13mm)	Factored Load Held.
Horizontal – Uniform Load		0.75 kN/m	51.4 lbf/ft	1.38" (35mm)	0.04" (1mm)	3.5" (89mm)	Deflection within allowable. Negligible permanent set.	1.5 kN/m	675 lbf/ft	1.50" (38mm)	0.16" (4mm)	Factored Load Held.
Vertical – Uniform Load		1.5 kN/m	103 lbf/ft	0.0" (0mm)	0.0" (0mm)	0.75" (19mm)	Deflection within allowable. Negligible permanent set.	3.0 kN/m	206 lbf/ft	0.0" (0mm)	0.0" (0mm)	Factored Load Held.
In-Fill Load	Mid-Height of Picket	0.5 kN	113 lbf	3.35" (85mm)	0.35" (9mm)	n/a	Withstood service loads.	1.0 kN	225 lbf	3.62" (92mm)	0.16" (4mm)	Factored Load Held.
Equivalent Horizontal Uniform Load at Intermediate Post		1.37 kN	308 lbf	--	--	3.5" (89mm)	See Note Below.	2.74 kN	617 lbf	1.97" (50mm)	0.24" (6mm)	Factored Load Held.

NOTE: Equivalent Horizontal Uniform Load at Intermediate Post was tested to measure load achieved at 50 mm deflection in lieu of measuring the deflection at required load. It is safe to assume that the deflection criteria at 1.37 kN (308 lbf) was met as the load to achieve 50 mm deflection was 2.70 kN (606 lbf).

**2020 NBC EVALUATION FOR HIDEAWAY BRANCH PRIVACY SCREENS**

SECTION	LOAD TYPE	LOCATION	REQUIRED	TEST 1	Y/N	TEST 2	Y/N
4.1.5.14	Concentrated Load	Panel	2.0 kN	2.0 kN	Y	2.0 kN	Y
		Connection		2.0 kN	Y	2.0 kN	Y
		Post		2.0 kN	Y	2.0 kN	Y
	Horizontal Line Load	Top Rail	1.5 kN/m	1.5 kN/m	Y	1.5 kN/m	Y
	In-Fill Load 100 mm x 100 mm	Panel	1.0 kN	1.0 kN <sup>2</sup>	Y	1.0 kN <sup>2</sup>	Y
	Vertical Line Load	Top Rail	3.0 kN/m	3.0 kN/m	Y	3.0 kN/m	Y
9.8.8.3	Height of Guards	Top Rail	-	> 1070 mm	Y	> 1070 mm	Y
9.8.8.5	Openings	Any	< 100 mm	≥ 100 mm <sup>3</sup>	N	≥ 100 mm <sup>3</sup>	N
9.8.8.6	Climbability	Any	< 45 x 20 openings	> 45 x 20	Y	> 45 x 20	Y



**2020 NBC EVALUATION FOR HIDEAWAY PRIVACY SCREENS – RIVER ROCK**

Test		Service Loads		Deflection		Allowable Deflection at Load	Observations at Service Load	Factored Loads		Deflection		Observations at Factored Load
				At Service Load	Residual					At Factored Load	Residual	
Concentrated Horizontal Load	Top of Post	1.0 kN	225 lbf	1.54" (39mm)	0.0" (0mm)	3.5" (89mm)	Deflection within allowable. Negligible permanent set.	2.0 kN	450 lbf	5.35" (136mm)	0.24" (6mm)	Factored Load Held.
	Mid-Span of Top Rail			<b>4.06"<sup>6</sup></b> <b>(103mm)</b>	0.35" (9mm)	2.125" (54mm)	Deflection <b>exceeds</b> allowable. Negligible permanent set.			4.72" (120mm)	0.28" (7mm)	Factored Load Held.
	End of Top Rail at Post			1.65" (42mm)	0.12" (3mm)	3.5" (89mm)	Deflection within allowable. Negligible permanent set.			2.68" (68mm)	0.12" (3mm)	Factored Load Held.
Horizontal – Uniform Load		0.75 kN/m	51.4 lbf/ft	1.26" (32mm)	0.0" (0mm)	3.5" (89mm)	Deflection within allowable. Negligible permanent set.	1.5 kN	675 lbf	1.42" (36mm)	0.0" (0mm)	Factored Load Held.
Vertical – Uniform Load		1.5 kN/m	103 lbf/ft	0.0" (0mm)	0.0" (0mm)	0.75" (19mm)	Deflection within allowable. Negligible permanent set.	3.0 kN/m	206 lbf/ft	0.0" (0mm)	0.0" (0mm)	Factored Load Held.
In-Fill Load	Mid-Height of Picket	0.5 kN	113 lbf	2.56" (65mm)	0.12" (3mm)	n/a	Withstood service loads.	1.0 kN	225 lbf	2.87" (73mm)	0.16" (4mm)	Factored Load Held.
Equivalent Horizontal Uniform Load at Intermediate Post		1.37 kN	308 lbf	--	--	3.5" (89mm)	See Note Below.	2.74 kN	617 lbf	1.97" (50mm)	0.24" (6mm)	Factored Load Held.

NOTE: Equivalent Horizontal Uniform Load at Intermediate Post was tested to measure load achieved at 50 mm deflection in lieu of measuring the deflection at required load. It is safe to assume that the deflection criteria at 1.37 kN (308 lbf) was met as the load to achieve 50 mm deflection was 2.89 kN (649 lbf).

**2020 NBC EVALUATION FOR HIDEAWAY RIVER ROCK PRIVACY SCREENS**

SECTION	LOAD TYPE	LOCATION	REQUIRED	TEST 1	Y/N	TEST 2	Y/N
4.1.5.14	Concentrated Load	Panel	2.0 kN	2.0 kN	Y	2.0 kN	Y
		Connection		2.0 kN	Y	2.0 kN	Y
		Post		2.0 kN	Y	2.0 kN	Y
	Horizontal Line Load	Top Rail	1.5 kN/m	1.5 kN/m	Y	1.5 kN/m	Y
	In-Fill Load 100 mm x 100 mm	Panel	1.0 kN	1.0 kN <sup>2</sup>	Y	1.0 kN <sup>2</sup>	Y
	Vertical Line Load	Top Rail	3.0 kN/m	3.0 kN/m	Y	3.0 kN/m	Y
9.8.8.3	Height of Guards	Top Rail	-	> 1070 mm	Y	> 1070 mm	Y
9.8.8.5	Openings	Any	< 100 mm	≥ 100 mm <sup>3</sup>	N	≥ 100 mm <sup>3</sup>	N
9.8.8.6	Climbability	Any	< 45 x 20 openings	> 45 x 20 <sup>4</sup>	Y	> 45 x 20 <sup>4</sup>	Y

---

**Note 2:** Upon removal of subject in fill load, deformation measurements were recorded by QAI, and permanent deformation of 3-9 mm was noted. This deformation as not considered to impact performance of the privacy screen for providing resistance load capacity and was considered cosmetic. As such, QAI considered the system to comply with in fill load requirements.

**Note 3:** QAI measured distance between ground surface and bottom of panel at 102 mm, allowing passage of spherical object. After review, QAI determined installation instructions allow adjustment of panel to reduce clearance from ground to panel bottom. This adjustment would reduce clearance to < 100 mm, meeting requirement for openings of 2020 NBC 9.8.8.5. As such, QAI considers Section 9.8.8.5 of the 2020 NBC met when installation ensures panels are within noted 100 mm allowance.

**Note 4:** Openings in the subject privacy screen were found to be within 450 mm spacing, and of opening size > 45 mm x 20 mm. While these privacy screens are of thin aluminum sheet that does not promote climbing without protection to hands due to thin metal edges, the measured openings do not comply with Section 9.8.8.6 (in addition to Section A-9.8.8.6 (1c)) of 2020 NBC. As such, these products should be limited to use where protection from a level > 4.2 meters height from an adjacent level exist.

**Note 5:** Concentrated loads were all applied at a height of 1067mm (42"). The Concentrated Load on the Panel was conducted at mid-span.

**Note 6:** Deflection measurements were taken during applied loads as directed by the 2015 NBC, and as required by Commentary F of 2015 NBC Part 4 Structural Commentaries. It should be noted that the Hideaway Inc. Privacy Screen system does not include a 'top-rail', so the application of the loads was applied directly to the screen (where applicable). In service, the load would be applied over a much larger area by the human body, and therefore the reported deflection data is somewhat misleading. It is QAI's opinion that the criterion was not specifically applicable at mid-span. Allowable deflection criteria can be found in ASTM E985-00(2006) which is referenced in Part 4, Commentary 'F' of the User's Guide Structural Commentary to the 2020 NBC, with the Commentary itself being referenced in the NBC.



---

## **CONCLUSIONS:**

Hideaway Inc. Branch, Dash and River Rock aluminum privacy screen products evaluated by QAI to 2020 NBC Section 4.1.5.14 *Loads on Guards Loads on Guards*, Sections 3.3.1.18 and 9.8.8.5 for maximum opening size limitations, and Section 9.8.8.6 *Climbability* was found to meet the load requirements with an applied performance factor of 0.75 for aluminum based on brittle failure subject to the following limitations:

Hideaway Inc. Branch, Dash and River Rock privacy screen products are to be installed with panels with spacing < 100 mm measured from floor line to bottom of screen to ensure maximum opening limits per Section 9.8.8.5 of 2020 NBC are met.

Hideaway Inc. Branch and River Rock privacy screen products were found to have openings spaced at < 450 mm, with openings sizes that do not comply with requirements for climbability per 2020 NBC Note A-9.8.8.6(1c) so as to not facilitate climbing. These products are not eligible for use where protection from a level > 4.2 meters to adjacent levels are required per Section 9.8.8.6 of the 2020 NBC.

## **DECISION RULE:**

Unless specifically stated or identified otherwise, QAI has utilized a simple acceptance rule to make conformity decisions on testing results contained in this report, as applicable.

## **ATTACHMENTS:**

Hideaway Screen Component and System Drawings

Appendix A - Hideaway Inc. Branch, River Rock and Dash QAI Tested Product Drawings

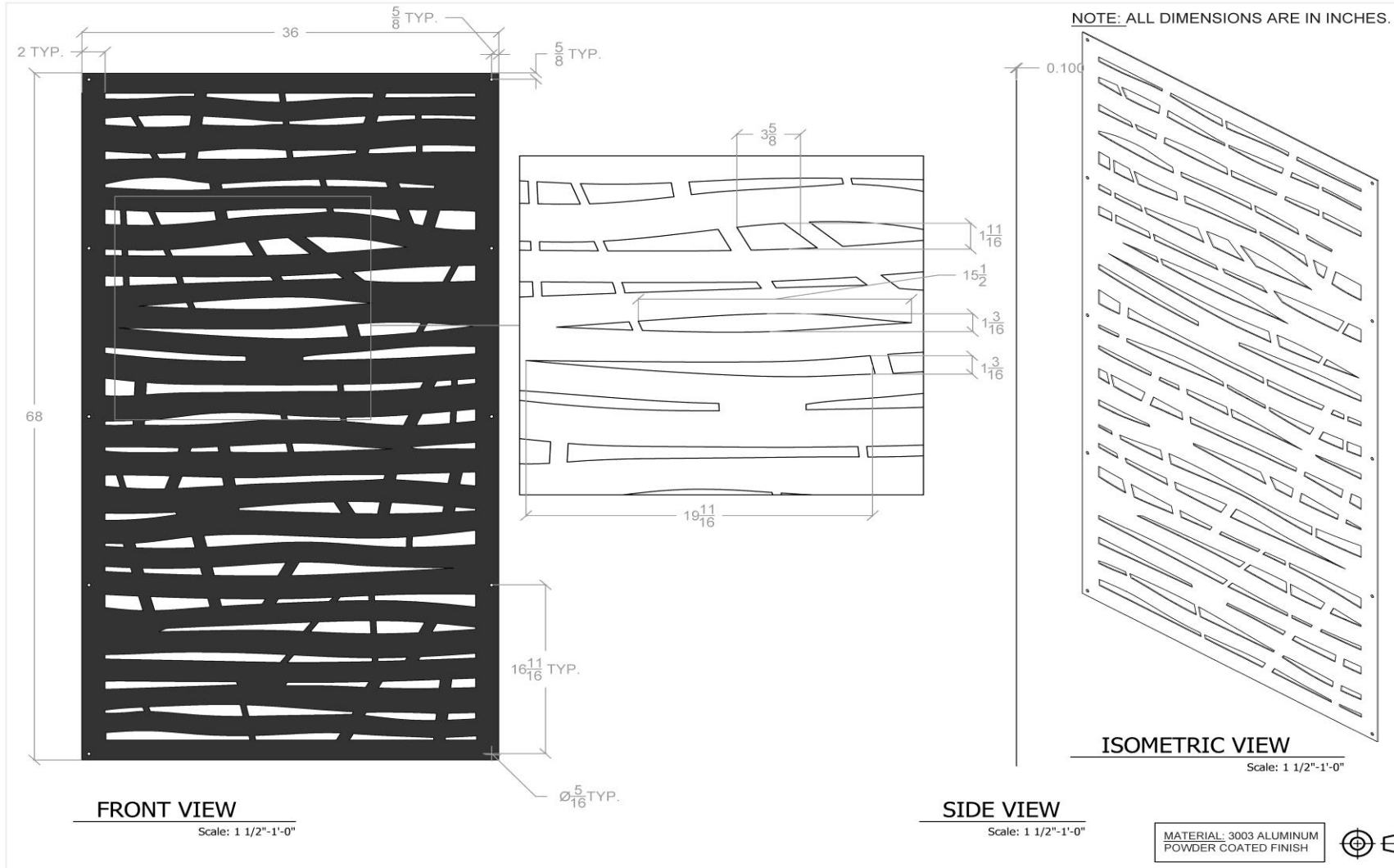

HIDEAWAY INC.  
 16142-114 AVE EDMONTON, AB  
 T5M 2Z5  
 P: 1-866-933-6833  
 E: INFO@HIDEAWAYSCREENS.CA

HIDEAWAY SCREENS  
 BRANCH DESIGN

DATE:  
 2022-06-03

SHEET NUMBER:  
 003

THIS REPORT IS THE CONFIDENTIAL PROPERTY OF THE CLIENT ADDRESSED. THE REPORT MAY ONLY BE REPRODUCED IN FULL. PUBLICATION OF EXTRACTS FROM THIS REPORT IS NOT PERMITTED WITHOUT WRITTEN APPROVAL FROM QAI. ANY LIABILITY ATTACHED THERETO IS LIMITED TO THE FEE CHARGED FOR THE INDIVIDUAL PROJECT FILE REFERENCED. THE RESULTS OF THIS REPORT PERTAIN ONLY TO THE SPECIFIC SAMPLE(S) EVALUATED.

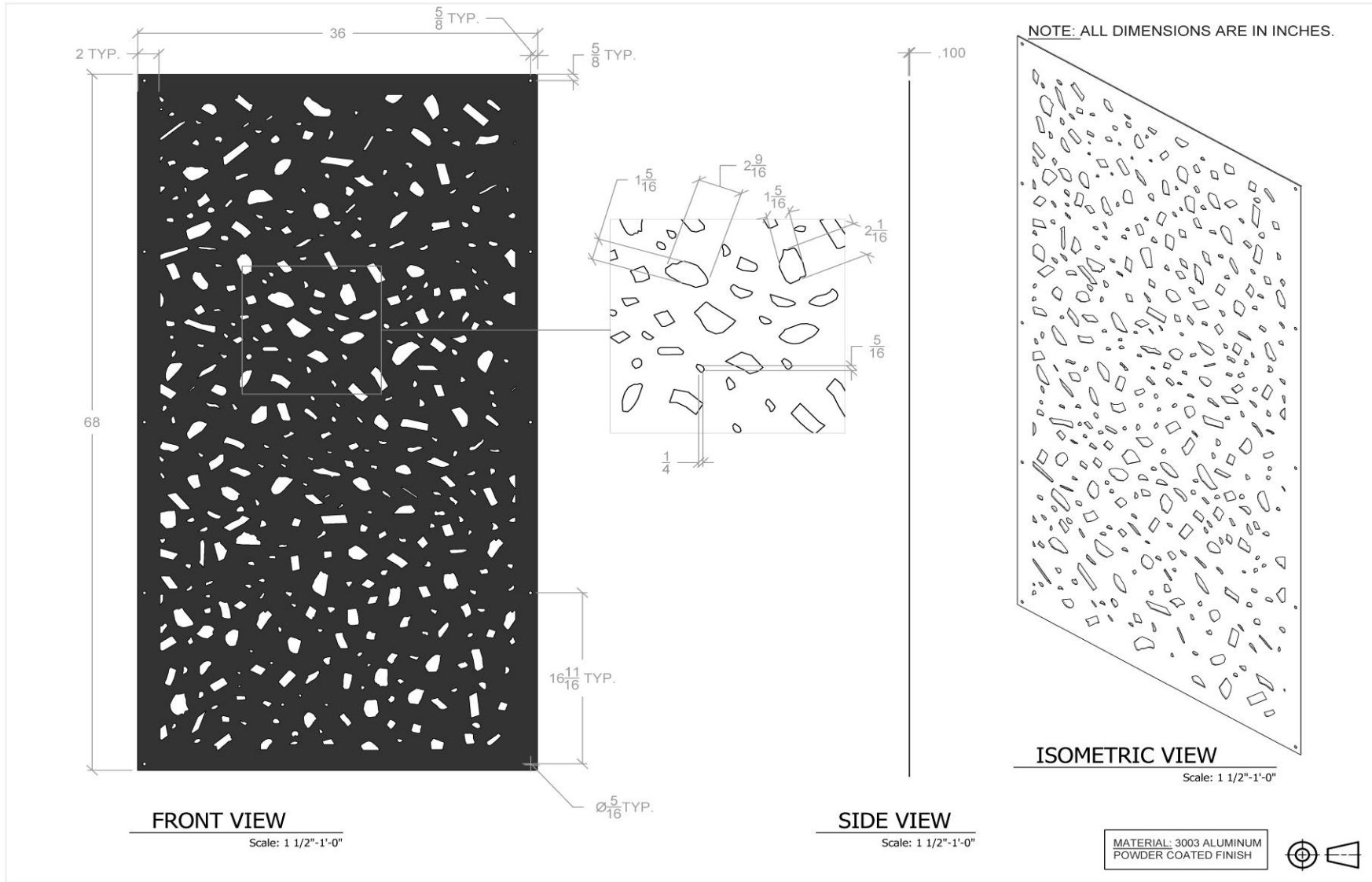

HIDEAWAY INC.  
 16142-114 AVE EDMONTON, AB  
 T5M 2Z5  
 P: 1-866-933-6833  
 E: INFO@HIDEAWAYSCREENS.CA

HIDEAWAY SCREENS  
 RIVER ROCK DESIGN

DATE:  
 2022-06-03

SHEET NUMBER:  
 .008

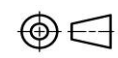

THIS REPORT IS THE CONFIDENTIAL PROPERTY OF THE CLIENT ADDRESSED. THE REPORT MAY ONLY BE REPRODUCED IN FULL. PUBLICATION OF EXTRACTS FROM THIS REPORT IS NOT PERMITTED WITHOUT WRITTEN APPROVAL FROM QAI. ANY LIABILITY ATTACHED THERETO IS LIMITED TO THE FEE CHARGED FOR THE INDIVIDUAL PROJECT FILE REFERENCED. THE RESULTS OF THIS REPORT PERTAIN ONLY TO THE SPECIFIC SAMPLE(S) EVALUATED.

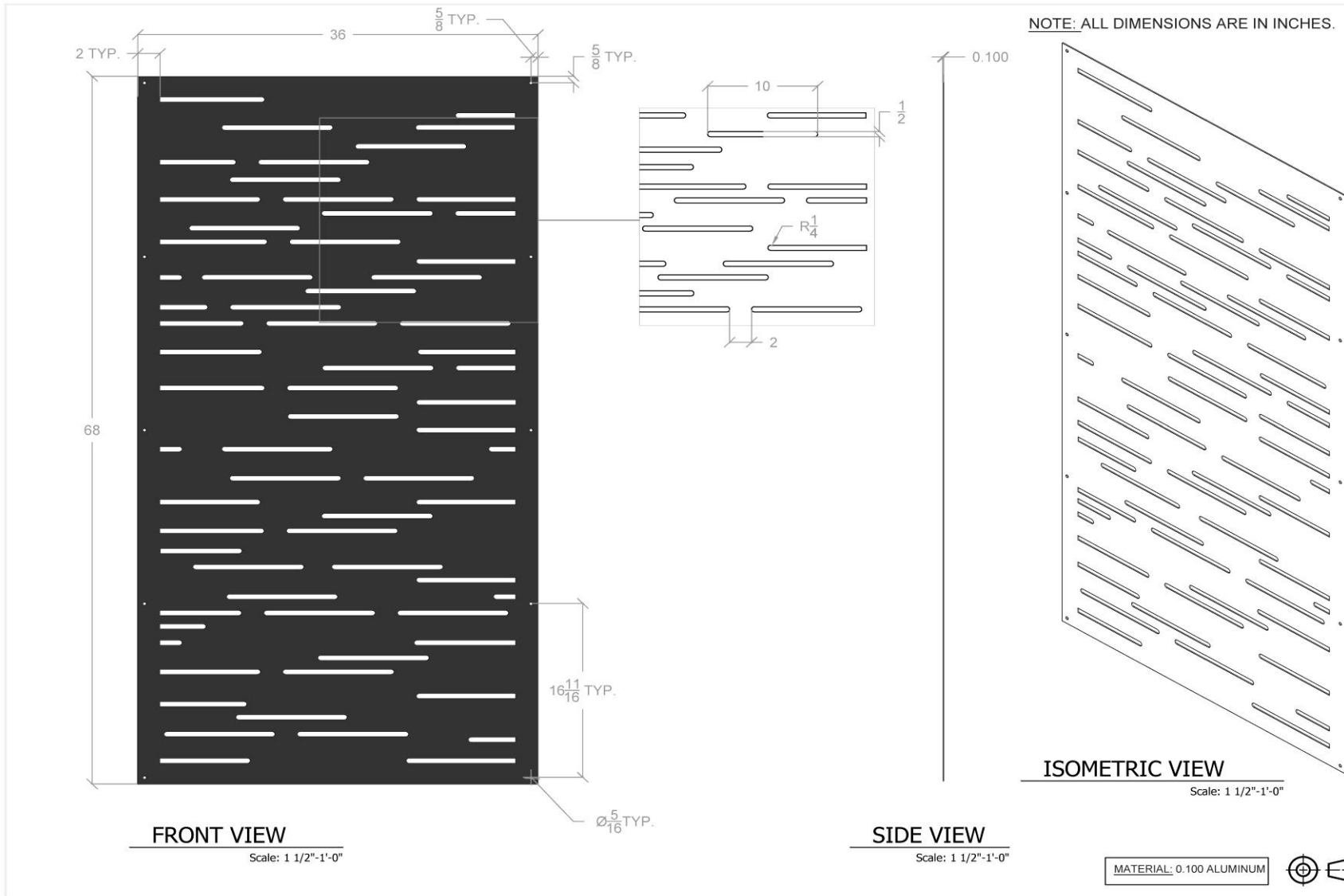

**HIDEAWAY**

HIDEAWAY INC.  
 16142-114 AVE EDMONTON, AB  
 T5M 2Z5  
 P: 1-866-933-6833  
 E: INFO@HIDEAWAYSCREENS.CA

**HIDEAWAY SCREENS**  
 DASH DESIGN

DATE:  
 2022-06-03

SHEET NUMBER:  
 009

THIS REPORT IS THE CONFIDENTIAL PROPERTY OF THE CLIENT ADDRESSED. THE REPORT MAY ONLY BE REPRODUCED IN FULL. PUBLICATION OF EXTRACTS FROM THIS REPORT IS NOT PERMITTED WITHOUT WRITTEN APPROVAL FROM QAI. ANY LIABILITY ATTACHED THERETO IS LIMITED TO THE FEE CHARGED FOR THE INDIVIDUAL PROJECT FILE REFERENCED. THE RESULTS OF THIS REPORT PERTAIN ONLY TO THE SPECIFIC SAMPLE(S) EVALUATED.

Appendix B - Mounting Brackets for Hideaway Screen Assemblies

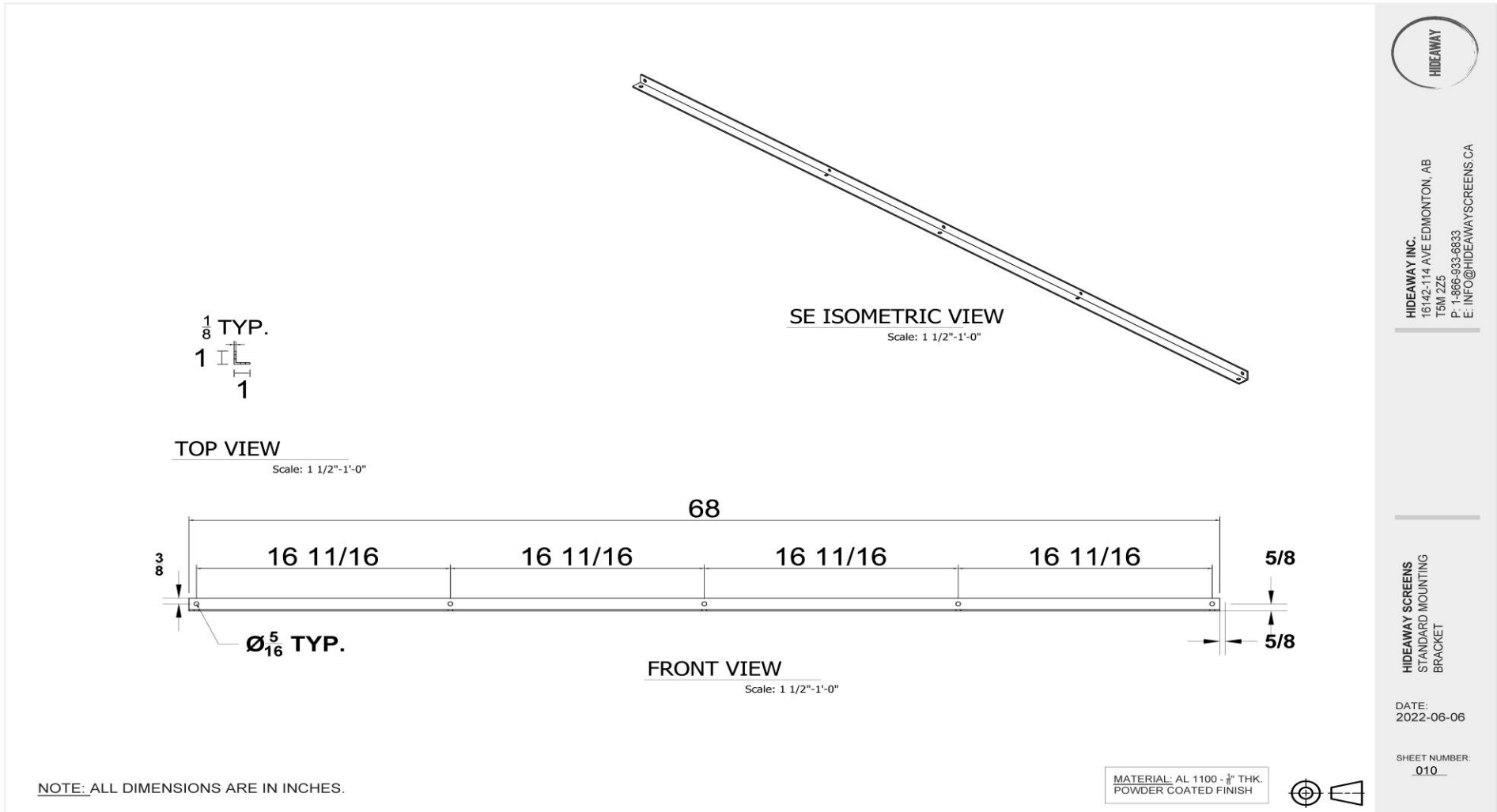

THIS REPORT IS THE CONFIDENTIAL PROPERTY OF THE CLIENT ADDRESSED. THE REPORT MAY ONLY BE REPRODUCED IN FULL. PUBLICATION OF EXTRACTS FROM THIS REPORT IS NOT PERMITTED WITHOUT WRITTEN APPROVAL FROM QAI. ANY LIABILITY ATTACHED THERETO IS LIMITED TO THE FEE CHARGED FOR THE INDIVIDUAL PROJECT FILE REFERENCED. THE RESULTS OF THIS REPORT PERTAIN ONLY TO THE SPECIFIC SAMPLE(S) EVALUATED.



### Appendix C - Mounting Posts for Hideaway Screen Assemblies

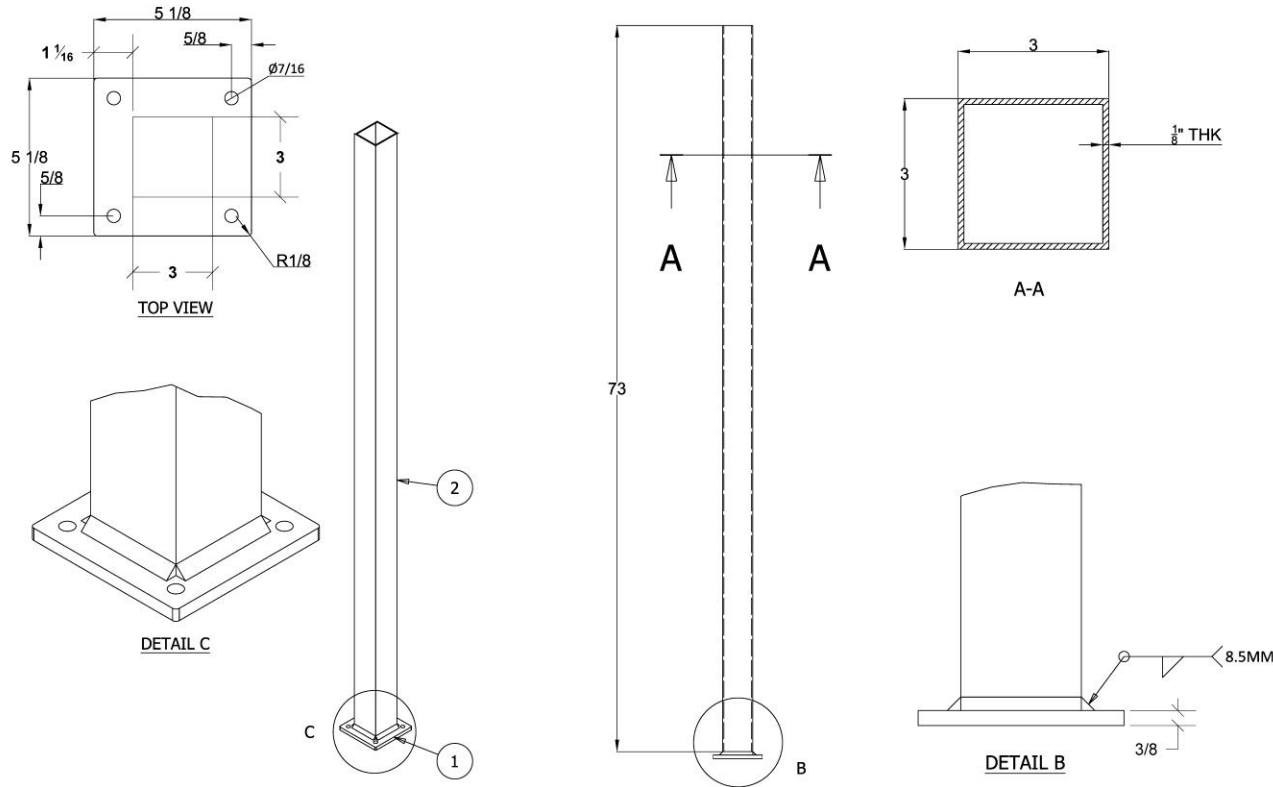

HIDEAWAY INC.  
 16142-114 AVE EDMONTON, AB  
 T5M 2Z5  
 P: 1-866-933-6633  
 E: INFO@HIDEAWAYSCREENS.CA

HIDEAWAY SCREENS  
 STANDARD 6' MOUNTING  
 POST

DATE:  
 2022-06-03

SHEET NUMBER:  
 011

ITEM	DESCRIPTION
2	Post
1	Base Plate
Parts List	

MATERIAL: 6063-T5  
 POWDER COATED FINISH



NOTE: ALL DIMENSIONS ARE IN INCHES.

### Appendix D - Hideaway Screen Assembly Details

**4 ACORN NUT**  
Scale: 1:1

$\frac{1}{8}$ " - 20- Pitch - .4675

$\frac{1}{8}$ "  $\varnothing \frac{1}{4}$

**5 MACHINE SCREW**  
Scale: 1:1

$\frac{1}{4}$ " - 20-  $\frac{1}{8}$ " Pitch - 0.4675

$\frac{1}{4}$ "  $\frac{1}{2}$ "

**7 SELF DRILLING SCREW**  
Scale: 1:1

10 - 24 Pitch - 0.685

$\frac{1}{8}$ "  $\frac{3}{4}$ "  $\frac{1}{2}$ "

**EXPLODED VIEW**  
Scale: 1"-1'-0"

**ISOMETRIC VIEW**  
Scale: 1 1/2"-1'-0"

ITEM	DESCRIPTION	QTY
9	Post Cap	2
8	Base Skirt	2
7	Self Drilling Screw	10
6	Mounting Bracket	2
5	Machine Screw	10
4	Acorn Nut	10
3	Privacy Screen	1
2	Post	2
1	Base Plate	2

Parts List



HIDEAWAY INC.  
 16142-114 AVE EDMONTON, AB  
 T5M 2Z5  
 P: 1-866-933-6833  
 E: INFO@HIDEAWAYSCREENS.CA

HIDEAWAY SCREENS  
 STANDARD ASSEMBLY

DATE:  
 2022-06-06

SHEET NUMBER:  
 .011



---

**REVISION SUMMARY:**

<b>Revision</b>	<b>Date</b>	<b>Comments</b>	<b>Eng/Tech</b>
0	July 15, 2022	Original Issue	R. Giona

\*\*\*\*End of Report\*\*\*\*