



Please read all instructions carefully before use and retain for future reference.  
Veuillez lire attentivement ces instructions avant utilisation et conservez-les pour pouvoir les consulter à l'avenir.  
Bitte lesen Sie die Anleitung sorgfältig und bewahren Sie sie als Referenz auf.  
Leed todas las instrucciones detenidamente antes de usar y retened para futuras consultas.  
Si prega di leggere attentamente tutte le istruzioni prima dell'uso e conservarle per una futura consultazione.



**70kg/154lbs**

Maximum Desktop  
Bureau maximum  
Maximaler Desktop  
Escritorio máximo  
Desktop massimo



**60min**

Estimated assembly time  
Temps d'assemblage estimé  
Geschätzte Montagezeit  
Tiempo Estimado de Ensamblaje  
Tempo stimato per il montaggio



2 person assembly required.  
2 personnes sont nécessaires pour l'assemblage.  
Für die Montage sind 2 Personen nötig.  
Se requieren 2 personas para el montaje.  
Per il montaggio sono richieste 2 persone.



Do not use power tools to assemble  
N'utilisez pas d'outils à moteur pour assembler  
Verwenden Sie zum Zusammenbauen keine Elektrowerkzeuge  
No uséis herramientas eléctricas para ensamblar  
Non utilizzare attrezzi elettrici per il montaggio



Do not climb on  
Ne grimpez pas dessus  
Steigen Sie nicht auf  
No os subais en el producto  
Non salirci sopra



Do not jump on  
Ne pas sauter sur  
Spring nicht drauf  
No saltar en  
Non saltare



Re-tighten fixings every 6 months  
Resserrez les fixations tous les six mois  
Befestigungen alle 6 Monate nachziehen  
Apretad de nuevo las fijaciones cada 6 meses  
Riavvitare le viti ogni 6 mesi



## EN

**INTENDED USE** This product is not intended for outdoor use. This product is not intended as a climbing structure and it is not a toy. Children should be supervised to ensure that they do not play with the product.

Follow each step of the assembly as outlined by the steps in this Instruction Manual.  
Assemble close to the products intended position.  
Locate the product in a suitable area where it will not create an obstruction.

**GENERAL SAFETY** The assembly pack may contain small parts which can pose a choking hazard to children and pets. Place on solid and even ground.  
Only use in an upright stable position.  
Do not overload the product as this may result in damage to the product or personal injury.

**CLEANING & MAINTENANCE** Do not clean the product with any abrasive cloths or chemicals. Solvents or detergents can cause damage to the surface. Periodically check and re-tighten fittings where applicable. Re-tighten all fittings after first week following assembly. To clean, sponge down with warm water, a soft cloth and mild detergent. Ensure you have all the pieces listed. If you are missing any components, contact our customer services department at [sales@yo-yodesk.co.uk](mailto:sales@yo-yodesk.co.uk)

Do not proceed with assembly if any components are missing.

## FR

**UTILISATION PRÉVUE** Ce produit n'est pas conçu pour une utilisation en extérieur. Ce produit ne doit pas être utilisé comme une échelle et ce n'est pas un jouet. Les enfants devraient toujours être supervisés pour s'assurer qu'ils ne jouent pas avec le produit.  
Suivez chaque étape de l'assemblage, comme indiqué dans les étapes de ce Mode d'emploi. Assemblez au plus près de la position prévue des produits. Placez le produit dans un endroit approprié, où il ne constituera pas un obstacle. Tenez éloigné de toutes sources de combustion.

**CONSIGNES GÉNÉRALES DE SÉCURITÉ** Ce paquet de montage contient de petites pièces qui pourraient présenter un risque de suffocation pour les enfants et les animaux de compagnie.  
Placez sur un sol solide et plat.  
N'utilisez qu'en position stable et verticale.  
Ne surchargez jamais le produit : ceci pourrait l'endommager ou entraîner des blessures.

**NETTOYAGE ET ENTRETIEN** Ne nettoyez pas le produit avec des chiffons ou des produits chimiques abrasifs.

Les solvants ou les détergents pourraient endommager la surface. De temps à autre, vérifiez et resserrez les fixations, utilisez une éponge et avec de l'eau chaude, un chiffon et un détergent doux. Vérifiez que vous avez toutes

les pièces listées. S'il vous manque des pièces, contactez notre département de service à la clientèle à

[sales@yo-yodesk.co.uk](mailto:sales@yo-yodesk.co.uk)

Ne procédez pas à l'assemblage s'il manque des pièces.

## DE

**NUTZUNGSZWECK** Dieses Produkt ist nicht für den Gebrauch im Freien vorgesehen. Dieses Produkt ist nicht als Klettergerüst gedacht und es ist kein Spielzeug. Kinder sollten beaufsichtigt werden. Stellen Sie sicher, dass Kinder nicht mit dem Produkt spielen.

Befolgen Sie jeden Schritt der Montage wie in den Schritten in dieser Bedienungsanleitung beschrieben. Montieren Sie das Produkt in der Nöhe des späteren Aufstellungsortes. Platzieren Sie das Produkt an einem geeigneten Ort, an dem es kein Hindernis darstellt.  
Halten Sie es fern von Zündquellen.

**ALLGEMEINE SICHERHEIT** Bei den Befestigungen sind kleine Teile enthalten, die eine Erstickungsgefahr für kleine Kinder und Haustiere darstellen. Stellen Sie das Produkt auf eine feste und ebene Fläche.  
Verwenden Sie es nur in aufrechter und stabiler Position. Überlasten Sie das Produkt nicht, da dies zu Schiden am Produkt oder zu Verletzungen führen kann.

**REINIGUNG & PFLEGE** Reinigen Sie das Produkt nicht mit Scheuertüchern oder Chemikalien. Lösungsmittel oder feinigungsmittel können die Oberfläche beschädigen. Überprüfen Sie die Befestigungen regelmäßig und ziehen Sie sie gegebenenfalls wieder an. Ziehen Sie alle Schrauben nach der ersten Woche nach der Montage wieder fest. Verwenden Sie zum Reinigen warmes Wasser, eine Schwamm und eine mildes Reinigungsmittel.  
Stellen Sie sicher, dass alle unten aufgeführten Komponenten enthalten sind. Sollten Teile fehlen kontaktieren Sie bitte unseren Kundendienst unter [sales@yo-yodesk.co.uk](mailto:sales@yo-yodesk.co.uk)

Fahren Sie nicht mit der Montage fort, wenn Komponenten vorhanden sind fehlt.

## ES

**USO PREVISTO** Este producto no es para uso en exteriores. Este producto no pretende ser una estructura de escalada y no es un juguete. Los niños deben ser supervisados para asegurarse de que no jueguen con el producto.

**ANTES DEL PRIMER USO** Siga cada paso del ensamblaje como se describe en los pasos de este Manual de instrucciones. Ensamble cerca de la posición prevista del producto. Ubicad el producto en un área adecuada donde no creará una obstrucción. Ubicad lejos de las fuentes de combustión.

**SEGURIDAD GENERAL** El paquete de ensamblaje contiene piezas pequeñas que pueden representar un peligro de asfixia para niños y mascotas. Colocad sobre suelo sólido y nivelado. Solo use en una posición vertical estable. No sobrecargue el producto, ya que puede dañar el producto o provocar lesiones personales.

**LIMPIEZA Y MANTENIMIENTO** No limpie el producto con paños abrasivos o productos químicos. Los solventes o detergentes pueden dañar la superficie.

Periódicamente revise y vuelva a apretar los accesorios cuando sea necesario. Vuelva a apretar todos los accesorios después de la primera semana después del ensamblaje. Para limpiar, utilizad una esponja con agua tibia, un paño y detergente suave. Tened todas las piezas en la lista. Si os falta algún componente, póngase en contacto con nuestro departamento de atención al cliente en [sales@yo-yodesk.co.uk](mailto:sales@yo-yodesk.co.uk)

NO proceda con el montaje si falta algún componente.

## IT

**USO PREVISTO** Questo prodotto non è destinato per uso esterno. Questo prodotto non può essere utilizzato come struttura per arrampicarsi e non è un giocattolo. I bambini devono essere supervisionati affinché non giochino con il prodotto.

**PRIMA DEL PRIMO UTILIZZO** Seguire ogni fase del montaggio come indicato nel Manuale delle istruzioni. Montare vicino alla posizione prevista per i prodotti. Posizionare il prodotto in un'area idonea e affinché non sia di ostacolo. Posizionare lontano da fonti di combustione.

**SICUREZZA GENERALE** La confezione per il montaggio contiene piccole parti che possono creare un pericolo di soffocamento per bambini e animali domestici. Posizionare su una superficie solida e in piano. Usare solo in posizione eretta e stabile. Non sovraccaricare il prodotto poiché ciò può danneggiare il prodotto o provocare lesioni personali.

**PULIZIA E MANUTENZIONE** Non pulire il prodotto con alcun panno abrasivo o agente chimico. I solventi o i detersivi possono provocare danni alla superficie. Controllare periodicamente e, dove necessario, riavvitare le viti. Dopo una settimana dal montaggio, riavvitare tutte le viti. Per pulire, insaponare con dell'acqua tiepida, un panno morbido e del detersivo delicato. Accertarsi di avere tutti i pezzi elencati. In caso di componenti mancanti, contattare il nostro servizio clienti su [sales@yo-yodesk.co.uk](mailto:sales@yo-yodesk.co.uk)

## COMPONENTS / COMPOSANTS / KOMPONENTEN / COMPONENTES / COMPONENTI /COMPONENTE

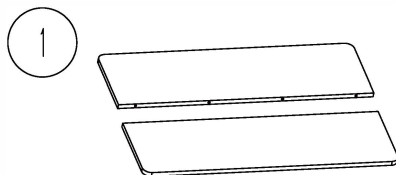

Desktop (x1)

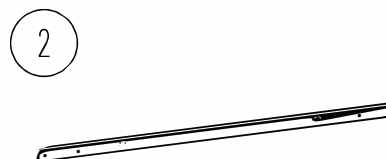

Crossbar (x1)



Side Plates (x2)



Transmission rod (x1)



Left Table Leg (x1)



Right Table Leg (x1)

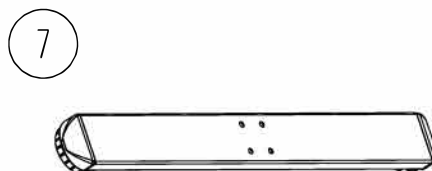



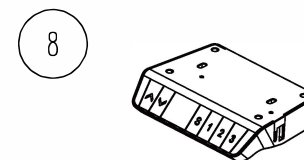



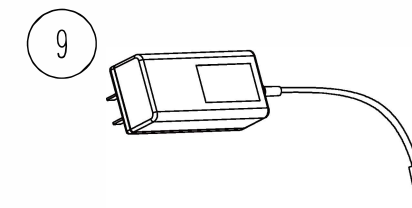

Leg Base (x2)

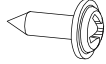
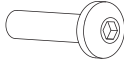



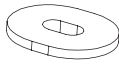

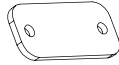

Controller (x1)



Power (x1)

<p><b>A</b></p>  <p>Screws M6×11mm (x8)</p>	<p><b>B</b></p>  <p>Screws M5×15mm (x16)</p>	<p><b>C</b></p>  <p>Screws M6×35mm (x8)</p>
<p><b>D</b></p>  <p>Screws M3.5×19mm (x2)</p>	<p><b>E</b></p>  <p>Allen Key S=2mm (x1)</p>	<p><b>F</b></p>  <p>Allen Key S=5mm (x1)</p>
<p><b>G</b></p>  <p>Rubber Pad (x10)</p>	<p><b>H</b></p>  <p>Cable Clip (x2)</p>	<p><b>I</b></p>  <p>Tabletop Connector (x3)</p>
<p><b>J</b></p>  <p>Wood Tip (x4)</p>		

**Spare Parts**





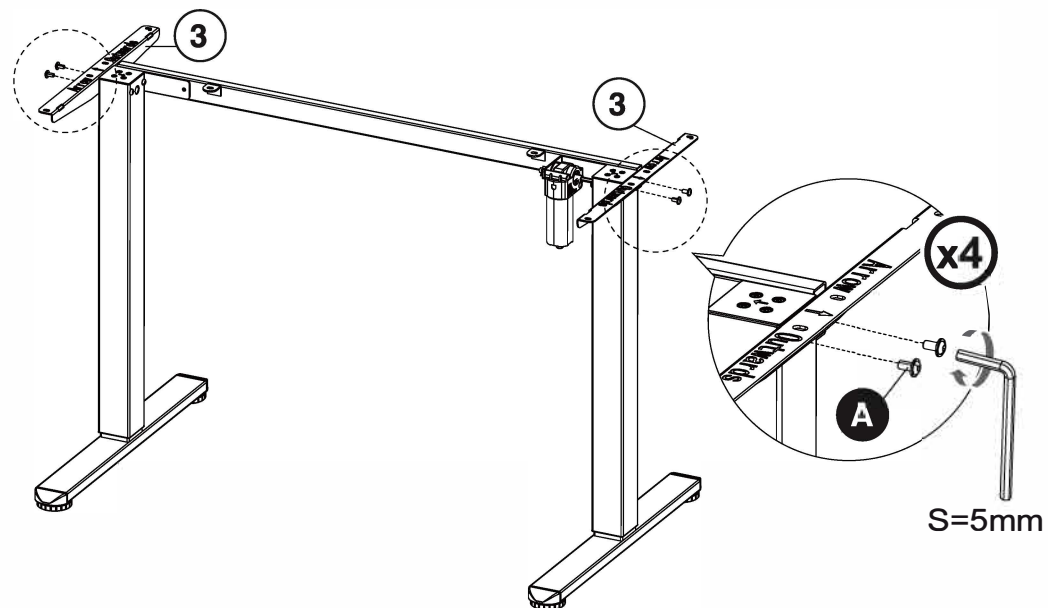
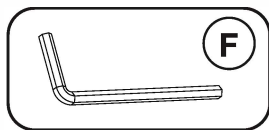
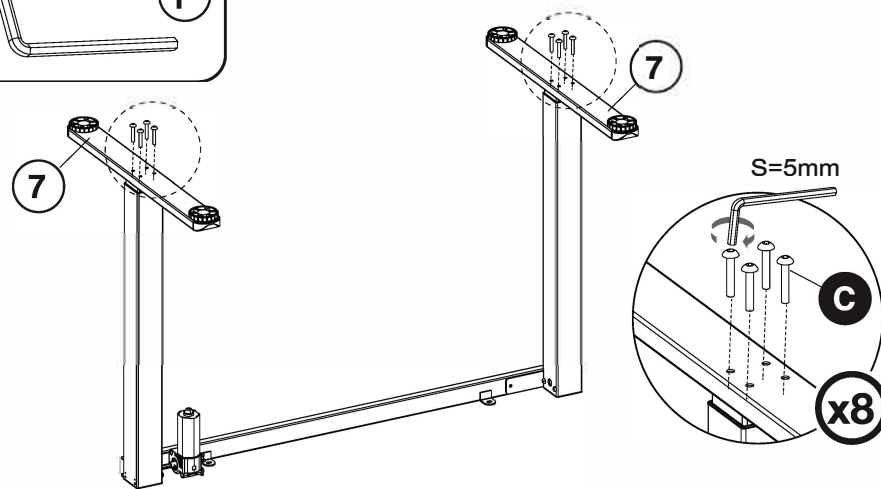
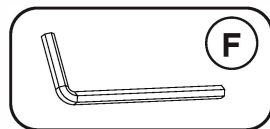
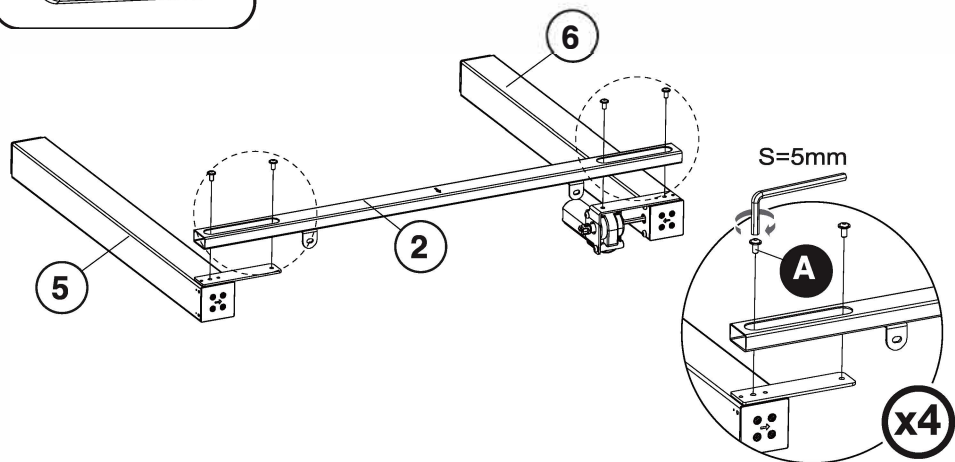
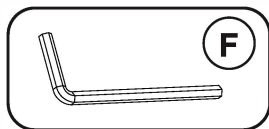

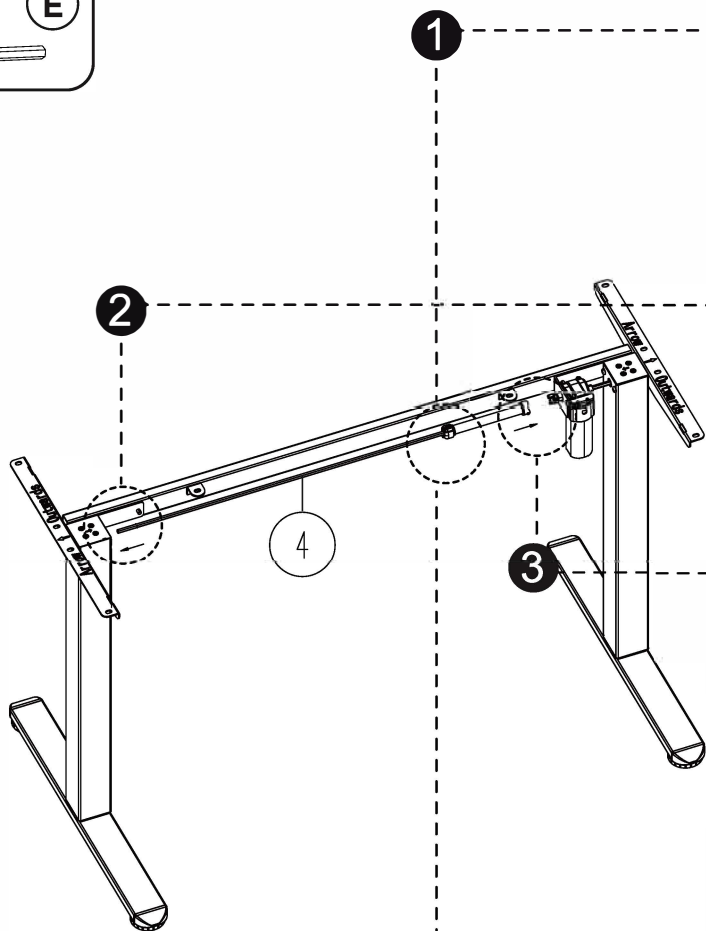
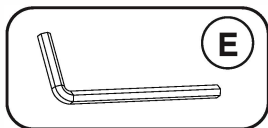

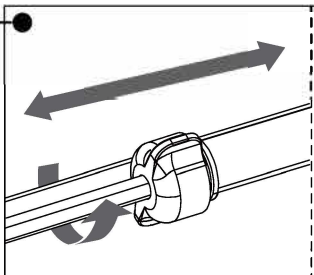
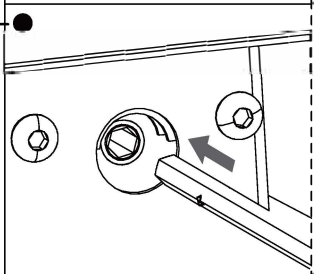
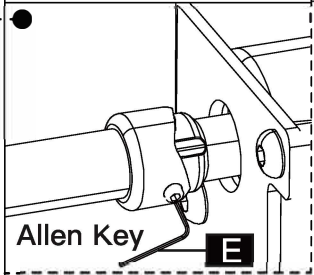
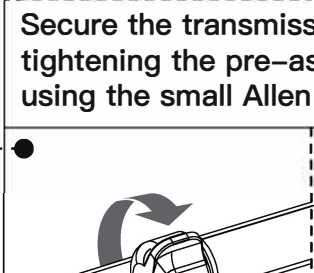
M6×11mm (x2) M5×15mm (x2) M6×35mm (x1) M3.5×19mm (x1) Rubber Pad (x2) Wood Tip (x2)

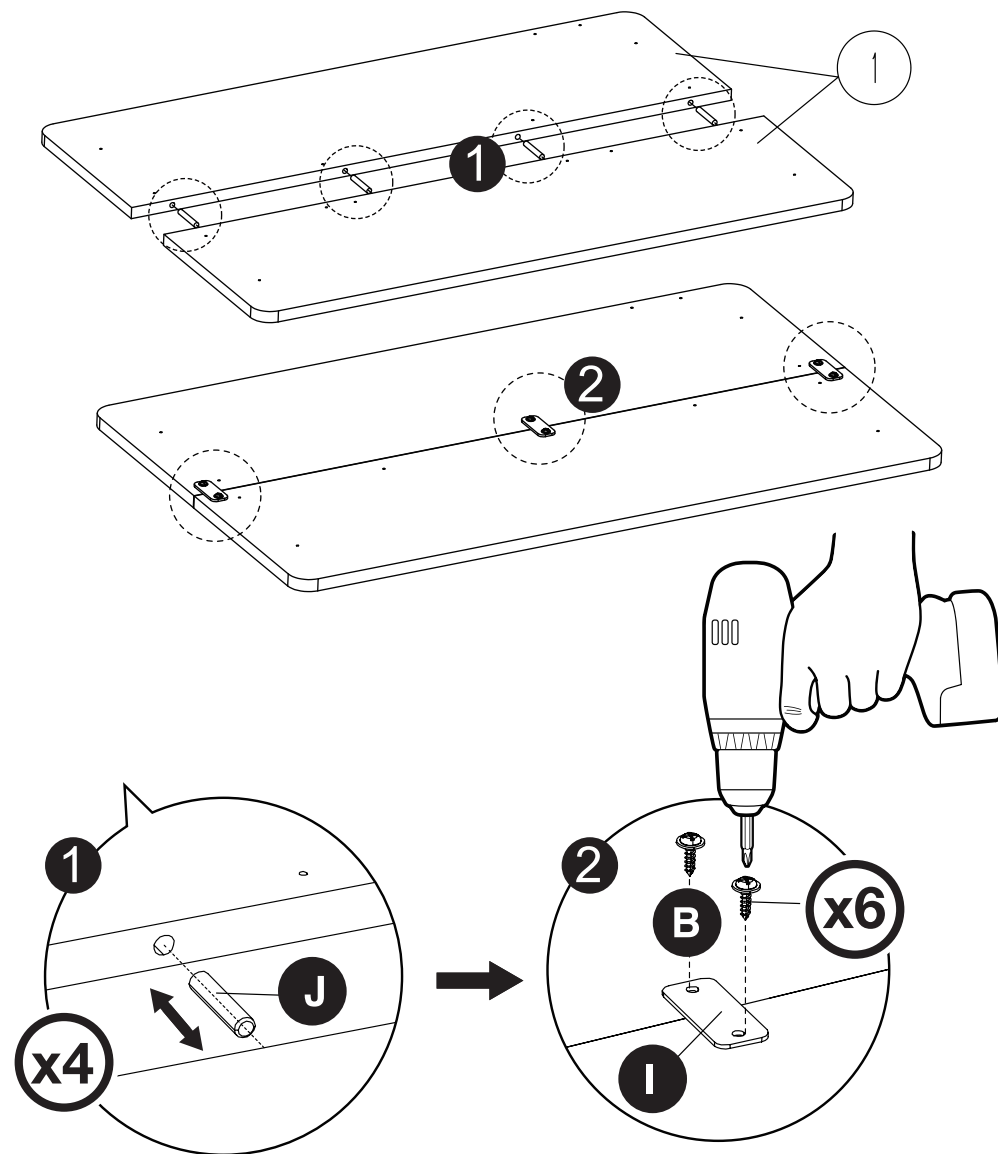
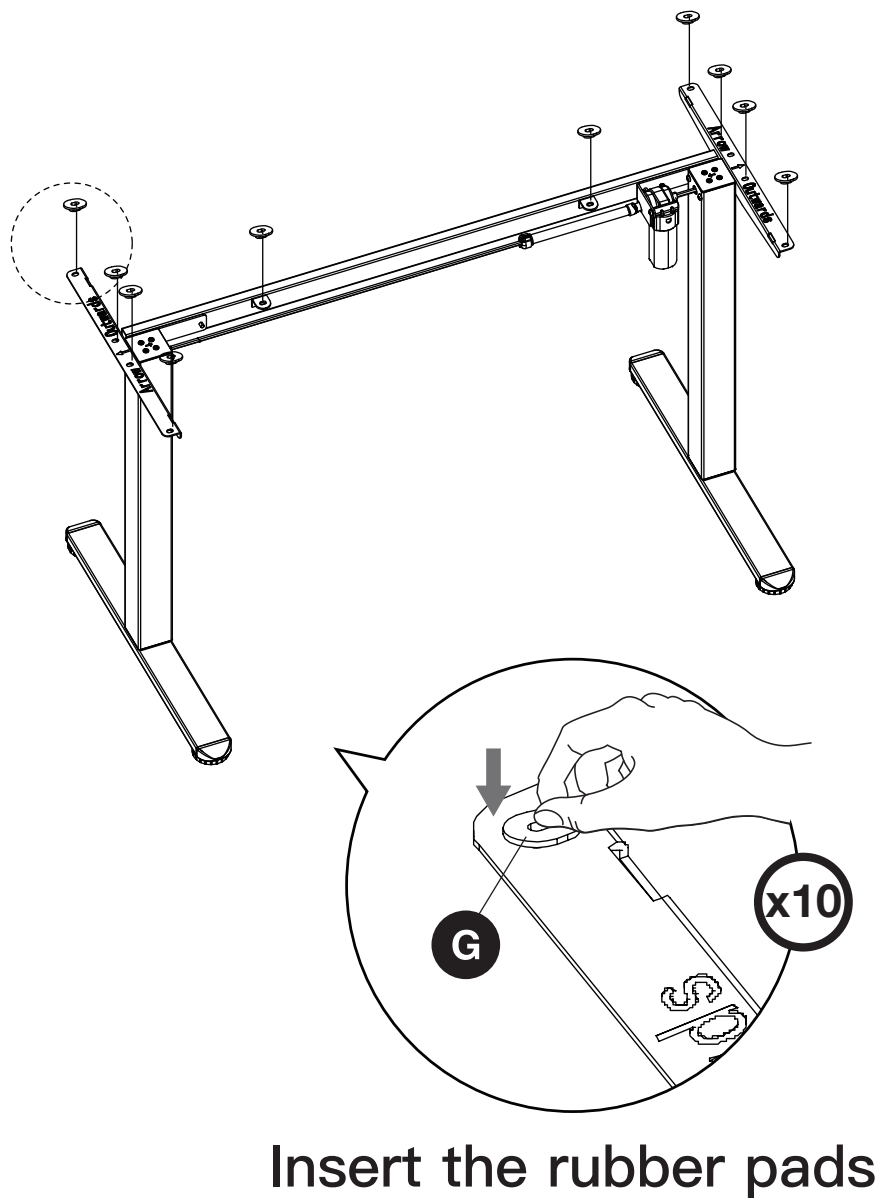



	① <b>Loosen the knob</b>
	② Insert the transmission rod into the hex hole and turn the transmission rod clockwise until the left leg goes to the lowest position.
	③ Insert the other end of transmission rod to the slot on the leg (You may rotate the rod slightly for better installation). <b>Allen Key E</b>
Secure the transmission rod to the slot by tightening the pre-assembled set screw using the small Allen key.	
	④ <b>Tighten the knob</b>



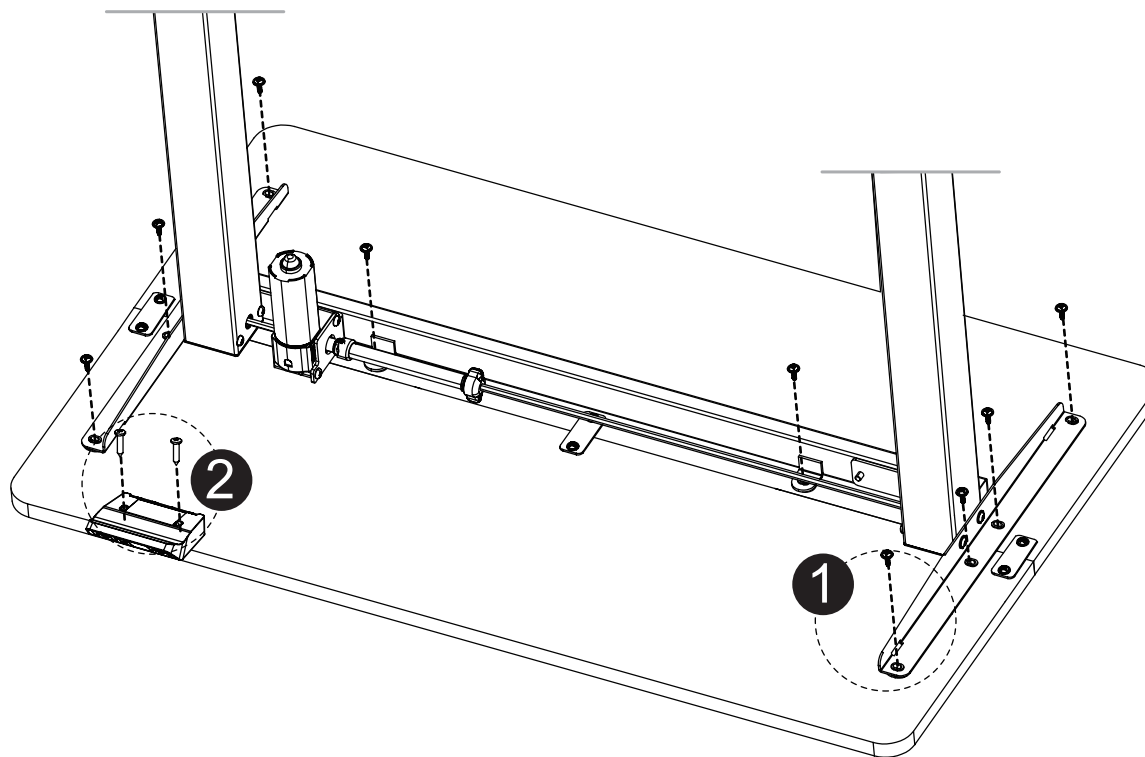
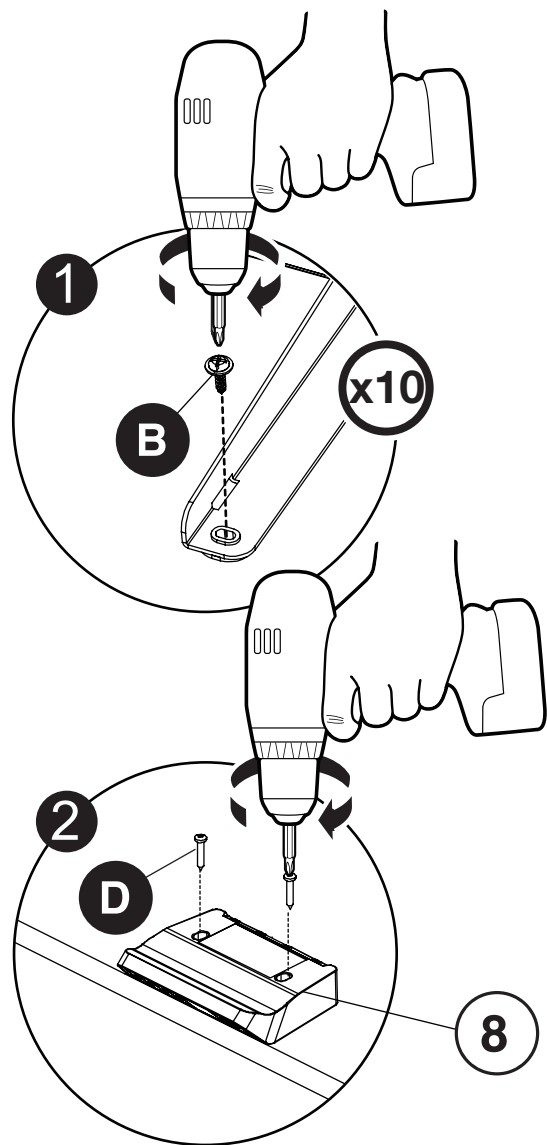

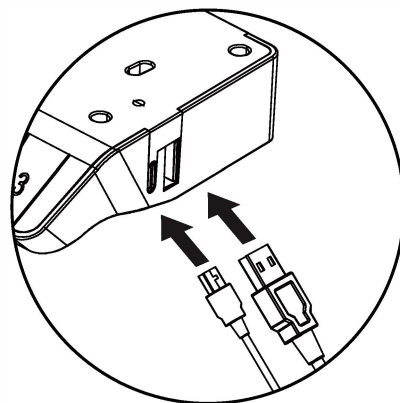
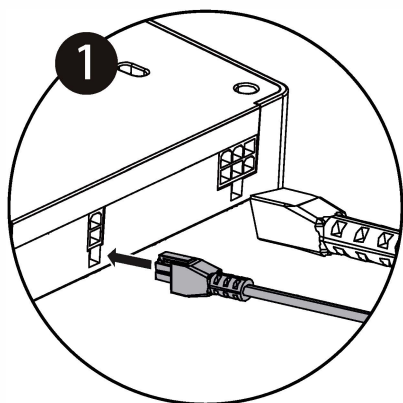
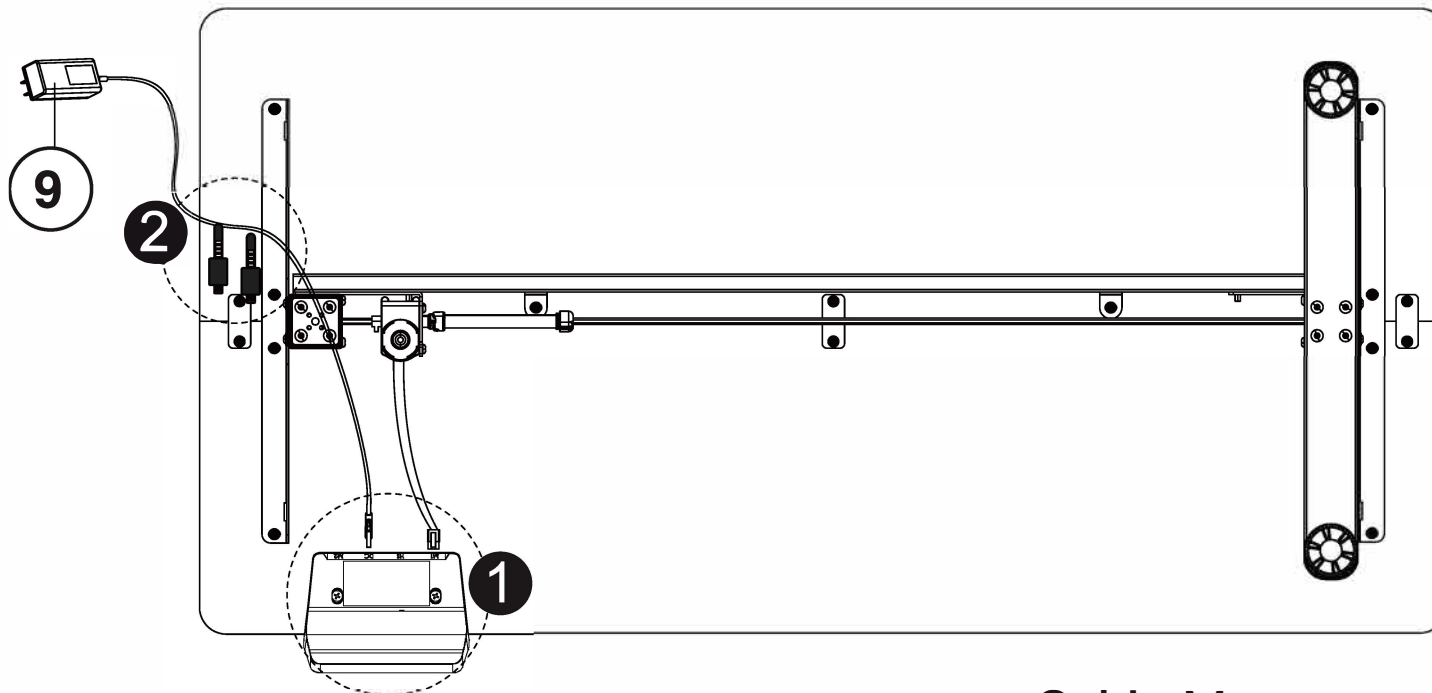

### Cable Management

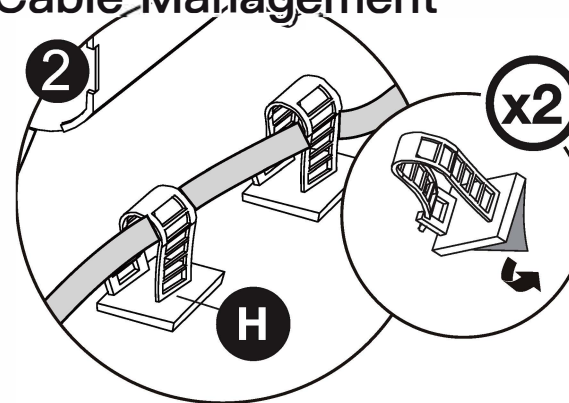



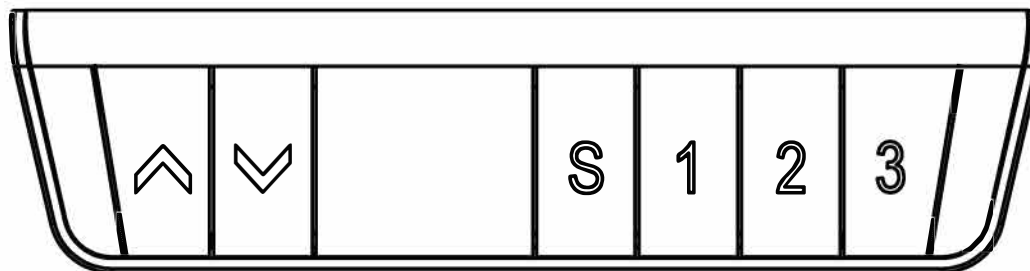

### Control Panel Keys



Adjust the desk upwards



Adjust the desk downwards



To set Height Preset, press the S button until the LED Display flashes then press Preset 1, 2, 3 to program preset.



Height Preset 1



Height Preset 2

























Height Preset 3

Reset

Press  for 5 seconds, the display will show 'RES' keep pressing the key until the legs move down to the lowest position.

Protection mode (auto lock screen mode)		
Hot	Over-heating protection	Alarms when continuously in motion for 5 minutes. Power back on and wait for at least 15 minutes before adjusting height again.
E10	Detection alarm	Alarms when motor sensor cannot be detected. Turn off power, check the connection of motor and control box, and then power back on.
E20	Overload protection	If alarm sounds when the desk is moving up, remove loads off the desk and try again. If it alarms when desk is moving down, turn off the power, remove loads off the desk and re-try.
E02	Rebound protection	Alarms when vibrated, collided or inclined during height adjustment. Check if there is anything in the way of desk motion. Then proceed to the reset the motor.
E32	Overvoltage alarm	It alarms when voltage is higher than anticipated value. Turn the power off, check the connection between power and control box. If no problem, power it back on.
E31	Undervoltage alarm	It alarms when voltage is lower than required value. Turn the power off, check the connection between power and control box. If no problem, power it back on.
E60	Step out alarm	It alarms when height difference between left leg and right leg exceeds the set value. Power off first. Check whether the left leg and the right leg are in the same height. If not, re-do Installation Step 3 to make them same height. Power it back on.
	Breaking protection	It stops and enters protection state when motor cables or manual control cables are removed or disconnected accidentally; goes back to normal after it's reconnected and alarm is cleared.

Engineering Mode	
Change Displayed Unit ( U <sub>n</sub> )	Long press the  button, "S--"shows and flashes. Press  again and the display shows "Un". Press  to select. Press  or  to switch between " 5   " (metric) or "   n " (imperial). Press  to save your choice.
Change Brightness (br)	Long press the  button, "S--"shows and flashes. Press  again and the display shows "Un". Press  or  to switch to "br". Press  to select. Press  or  to switch between Low (L), Normal (n) or High (H) brightness. Press  to save your choice.
Collision Force Detection (CF)	Long press the  button, "S--"shows and flashes. Press  again and the display shows "Un". Press  or  to switch to "CF". Press  to select. Press  or  to switch between "OFF", Low (L), Normal (n) or Heavy (H) collision force detection. Press  to save your choice.