



# 800 SERIES FRYER

## 2 baskets

### VFGIL - Gas

- "V" pan fryer combines high energy efficiency, quick response and recovery and cooking flexibility
- +/- 2°C precision thermostat for optimum control
- Rapid heating response and continuous pilot ignition
- Stainless Steel pan for easy cleaning
- Cover/joiner strips available for multi-unit installations
- Large cool zone for long oil life
- Line-up nosing

#### Other options

Night lid

Cover/joiner strips

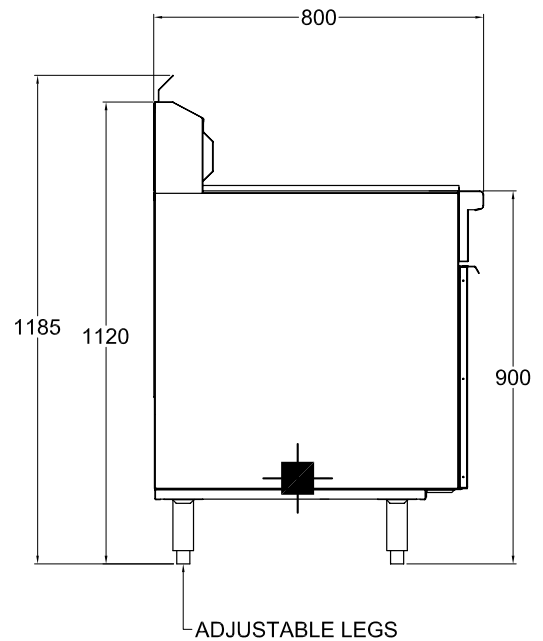
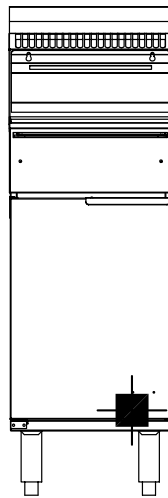
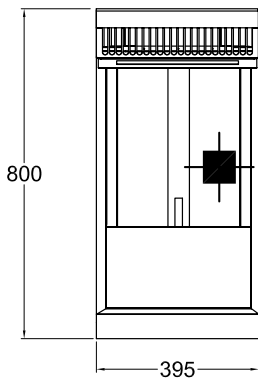

### VFGIL 2 baskets

#### SPECIFICATIONS

<b>Dimensions (WxDxH)</b>	395 x 800 x 1120 mm
<b>Working height</b>	900 mm (±20 mm)
<b>Pan Size (WxDxH)</b>	353 x 353 x 300 mm
<b>Capacity</b>	20 L

■ 3/4" BSP Gas Connection

<b>Gas Connection</b>	3/4" BSP
<b>Rating</b>	97 Mj
<b>Weight</b>	70 kg
<b>Packed</b>	0.4 m <sup>3</sup>

Australia's premier food service equipment manufacturer

[goldstein.com.au](http://goldstein.com.au)

211-217 Woodpark Road, Smithfield NSW 2164  
1800 013 123 | +61 2 9604 7333

 **MIDDLEBY AUSTRALIA**

