











 Model	EW800R	
Code Production	TT3823REWZDD +RC	
Interface :		



	Overall Dimension (Width-Depth-Height) *open	mm	721 - 836 - 2265
	Packaging Dimension (WxDxH) +(additional RC package)	mm	870x760x1540+(800x750x300)
	Gross weight +(RC)	Kg	115+(25)
	Net weight +(RC)	Kg	105+(23)
	Volume +(RC)	mc	1,02+(0,15)
	Rack size	mm	500x500
	Max door /hood opening	mm	465
	Max glasses/plate Height	mm	440
	General construction		double skin
	Door/hood Construction		single skin
	Tank construction		deep drawn
	Tank volume	liter	22
	Tank heating element	W	2.500
	Tank surface strainers		Yes- composite
	Wash pump type		double flow
	Wash pump power	W	700
	Wash temperature	°C	60
	Boiler type		without pressure
	Boiler volume	liter	12
	Back-flow system		break tank
	Boiler heating element	W	6.000
	Rinse booster pump		yes
	Rinse booster pump power	W	200
	Rinse temperature	°C	80
	Rinse water consumption	Liter /rack	1,9
	Optimal external water pressure	bar	1 - 4
	Drain system		deep drain
	Drain pump		standard built in
	Rinse aid dispenser	peristaltic	YES
	Detergent dispenser	peristaltic	YES
	Wash cycle	sec	60 - 120 - 150 - continuous
	Self cleaning		YES
	Automatic drain		NO
	Heat recovery fan	W	50
	Heat recovery air flow	m ³ /h	680
	Residual heat emission SENSITIVE	KW	0,6
	Residual heat emission LATENT	KW	0,5
	Electric Power	W	6.700
	Electric Connection	V - ph - Hz	400V 3N 50Hz
	Fuse	A	16
	Plates racks	n° 1	780131
	Flat Rack	n° 1	780132
	Cutterly Rack	n° 1	780139

Electric cable	n° 1	YES
Drain hose	n° 1	YES
Fill hose	n° 1	YES

A		∅ 32 mm
B		G 3/4"
C		Power supply

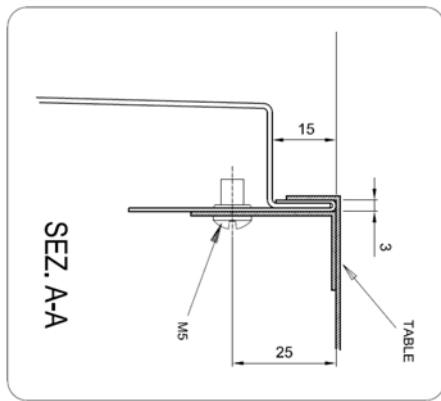
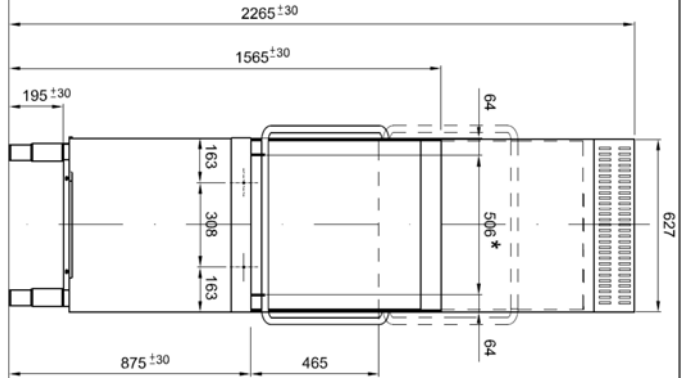
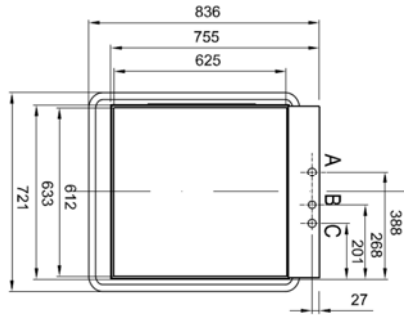

* LUCE UTILE PER CESTELLO
USEFUL SPACE FOR BASKET
LUMIERE OUTIL POUR PANIER
NUTZARE OFFENUNG FÜR KORBE
ABERTURA UTIL PARA CESTO

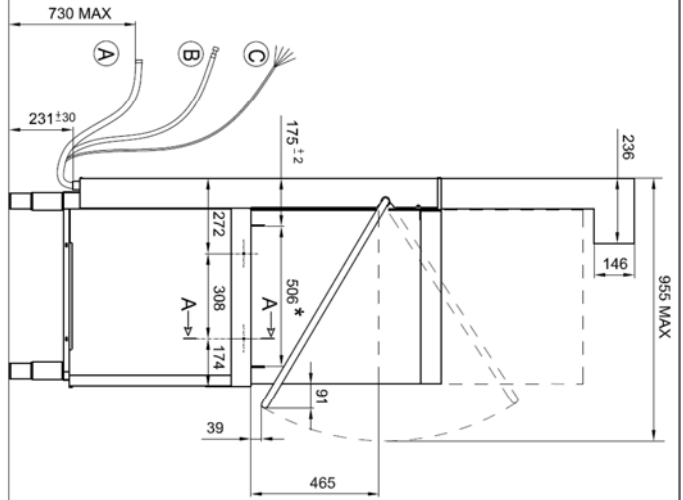

Designed by: M.FUCCI
Date: 03.12.2013

Installation layout

Hood type with steam condenser
with drain pump

Cod.: 73993
Rev.: 01

