



RAPID FRYER SERIES: RF-3

Three Pan Rapid Fryer

Project: _____ Item: _____



RF-3

Standard Features:

- AISI Grade Stainless Steel
- Stainless steel constructed pan with center cool zone – 2mm Thick
- Efficient multi-jet target burner
- +/- 3°C temperature recovery differential
- Over-temperature safety cut-out switch
- 40L oil capacity
- Heavy duty lockable oil drain valve
- Flame Failure - Included as standard
- Piezo ignition to pilot multi-jet target burner
- Stainless steel wire tray and night cover included
- Front access to all components makes service easy
- Pan Dimensions: 510mm D x 510mm W x 80mm H
(Height is measured from the base plate to the oil level mark)

Options:

- Natural or LPG Gas
- Perforated fish plate

Specifications:

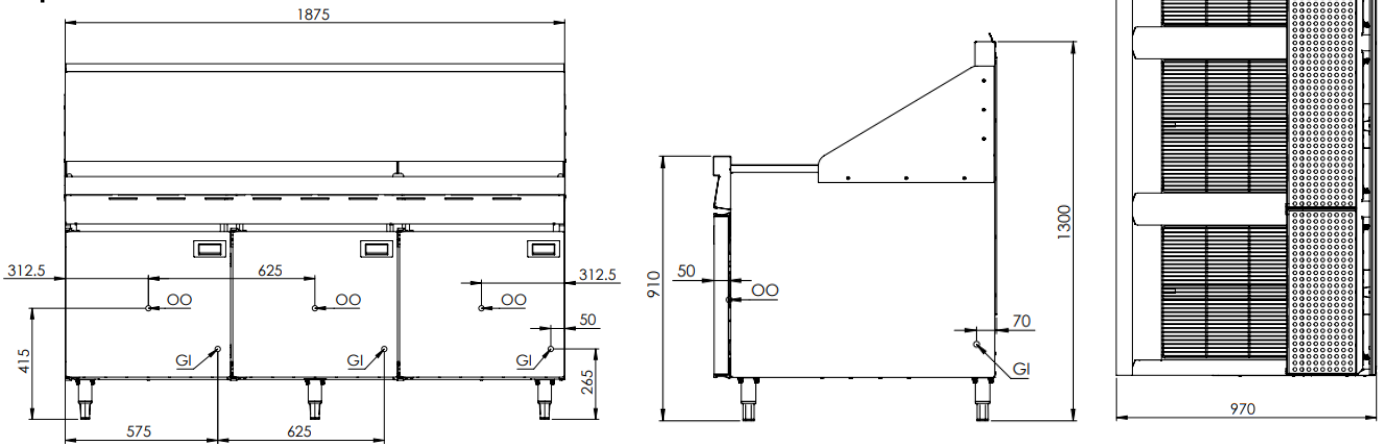

MODEL	LENGTH (mm)	DEPTH (mm)	HEIGHT (mm)	NET WEIGHT (kg)	GAS CONSUMPTION (Mj/h)	
					NG	LPG
RF-3	1875	970	1300	-	405	405

Connections:

GAS (GI) (BSP)	OIL OUTLET (OO) (BSP)	SUPPLY PRESSURE (kPa)	
		NG	LPG
3/4" (M)	1 1/4" (F)	1.0	2.6

- Combination control valve with inbuilt regulator is supplied within the unit
- **Must** be installed by an authorised installer in accordance to **AS/NZS5601** refer to current version

Due to ongoing Product Development, Product Improvement and Research, B+S Commercial Kitchens reserves the right to alter specification without notice.

Approval Number: GMK 10683



B+S Commercial Kitchens
57 Plateau Road Reservoir VIC 3073 Australia | +61 3 9469 4754
info@bscommercialkitchens.com | www.bscommercialkitchens.com

