



USER GUIDE AND INSTALLATION MANUAL

POWERLOCK KEYLESS ENTRY KIT 5

Our Powerlock keyless Entry kit converts your classic car into a keyless entry system.

The Remote Keyless Kit are the latest technology from Bluewire Automotive Australia.



IMPORTANT INFORMATION!

Disconnect the battery before fitting.

Always best fitted by a professional auto electrician.

Unit Installation

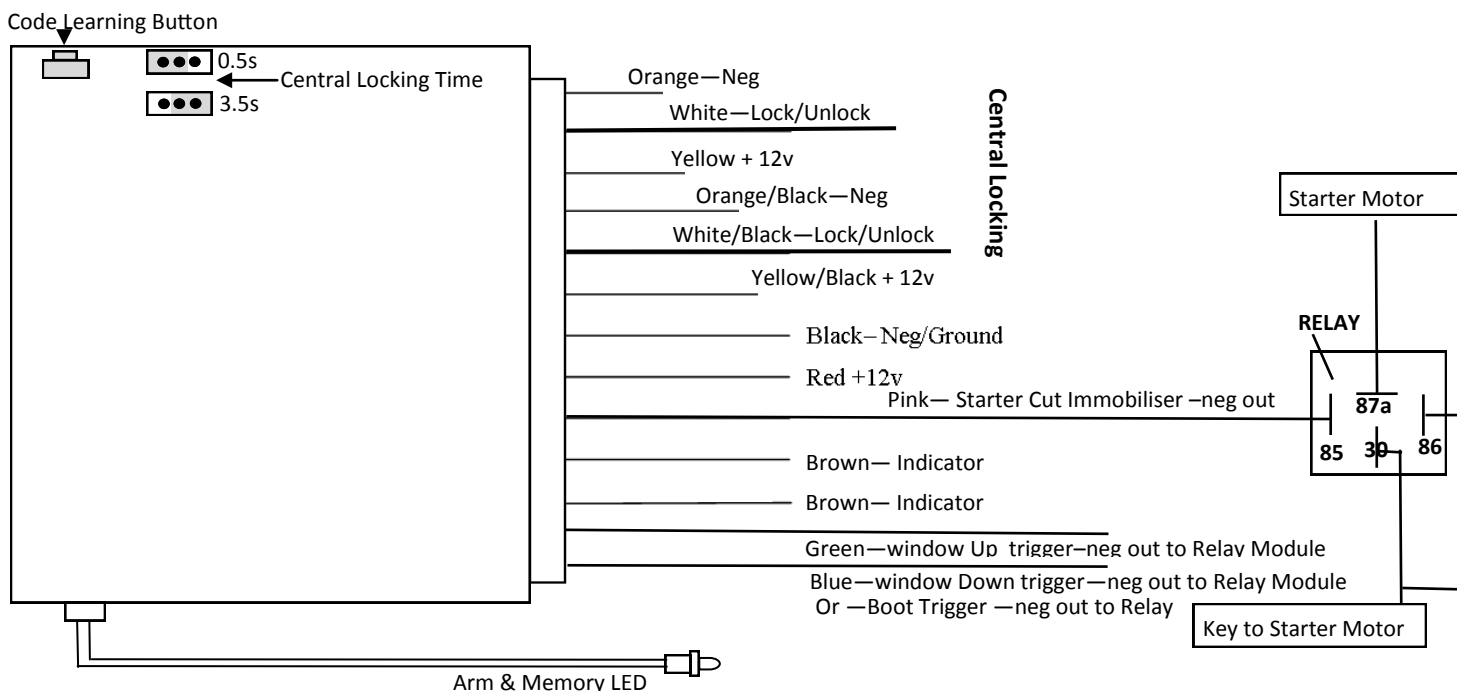
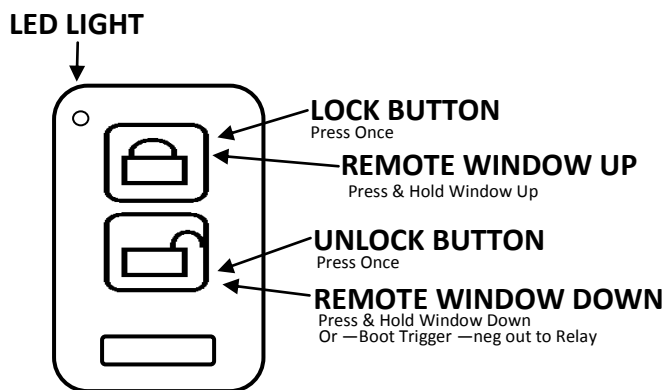



USER GUIDE AND INSTALLATION MANUAL

CENTRAL LOCKING WIRING DIAGRAMS

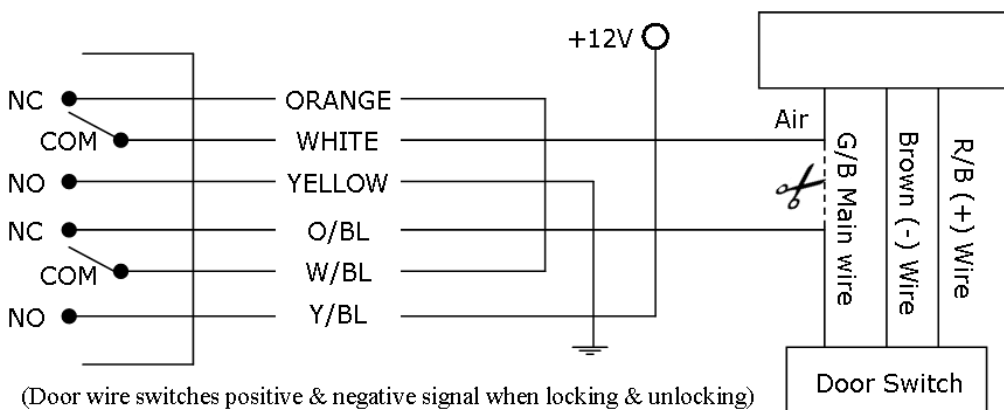
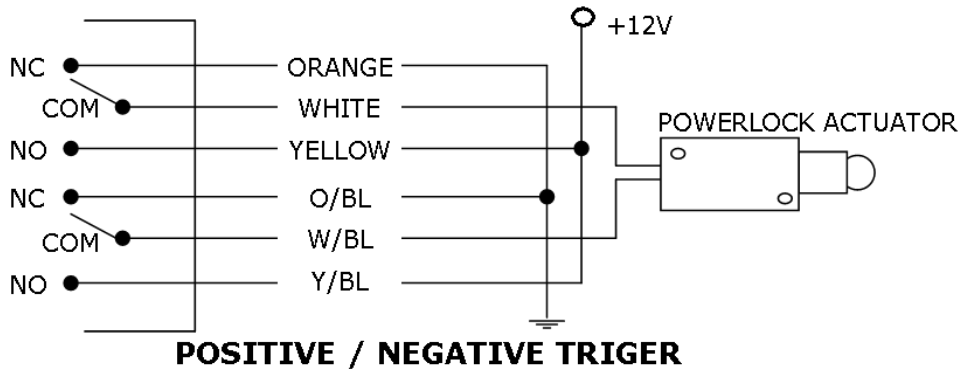
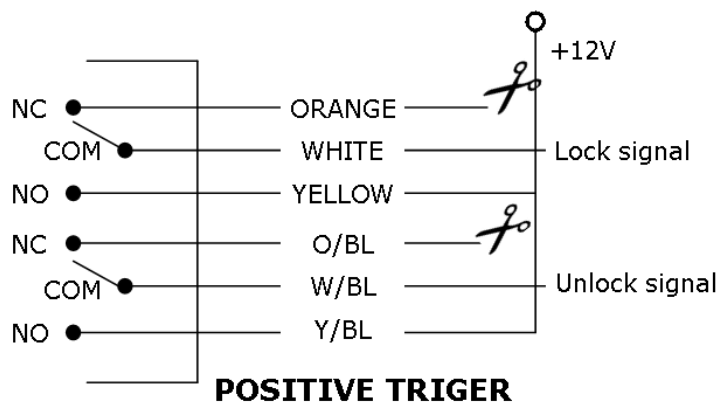
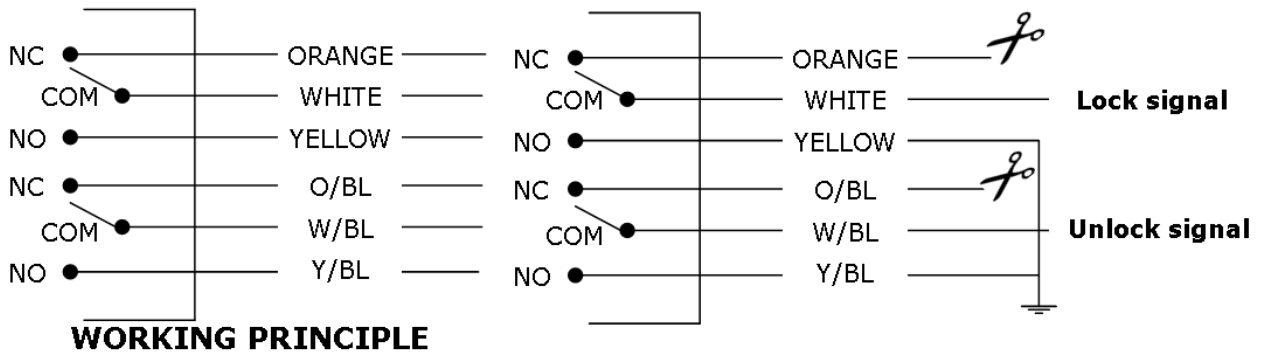



USER GUIDE AND INSTALLATION MANUAL

Power Window Up & Down Feature

From Keyless Module

Blue—Window Down—neg out to Relay

From Keyless Module

Green—Window Up—neg out to Relay

Blue

Green

Use 2 x 30amp /40amp Relays

+12v DC

30amp Fuse

From Power Window Switch

From Power Window Switch

To Power Window Motor

To Power Window Motor

