

AURORA SERIES GAUGES



GAUGE INSTALLATION

1. Select mounting locations for the fuel gauge.
2. Cut a 2 1/16" (52 mm) diameter hole for the gauge and test for proper fitmate.
3. Tighten the gauge with the enclosed Aurora Mounting Clamp until the gauge is secure and can no longer be rotated.

SUGGESTED TOOLS AND MATERIALS

- 18 Gauge Stranded, Insulated Wire
- Insulated 1/4" Spade Terminals
- 2 1/16" and 3 3/8" Hole Saws
- Drill and Drill Bit Set
- Bolt Cutter or Similar Tool
- Half-Round File
- Tape Measure
- Wrench or Nut Driver Set
- Phillips Screw Driver
- Utility Knife
- Gas-Proof Gasket Sealant

CAUTION : Read these instructions thoroughly before installing product. Do not deviate from assembly or wiring instructions. Always disconnect battery ground before making any electrical connections. If in doubt, please contact your authorized dealer or Aurora Instruments.

MOUNTING HOLE TEMPLATES

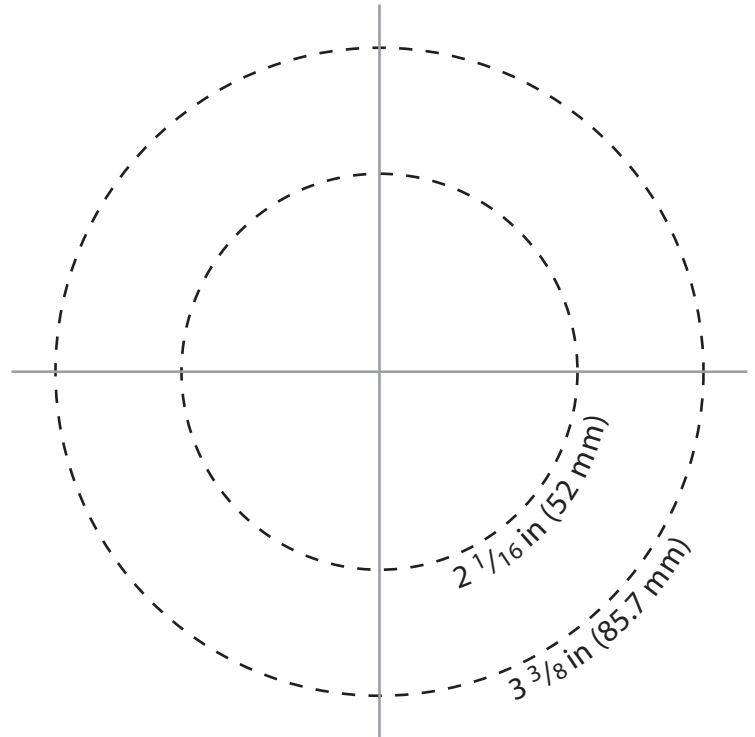

FUEL GAUGE



PARTS LIST

Description	Quantity
Fuel Gauge (2 1/16" Diameter)	1
Fuel Level Sender	1
Float Arm	1
Aurora Mounting Clamp for Gauges	1
Instrument Kit Installation Instructions	1

FUEL LEVEL SENDER INSTALLATION

When the tank is empty, the Fuel Level Sender will have a resistance rating of 10 Ω, and 180 Ω when the tank is full. Matching fuel gauges can be ordered from the Aurora catalog and web site. This unit reads accurately in tanks from 6" to 23" deep, and needs to be adjusted accordingly. Refer to the Sender Adjustment Chart and the Fuel Level Sender Diagram for sender adjustment.

- Match the measured the depth of your fuel tank and locate this dimension in the Sender Adjustment chart under Column "1". Column "2" indicates the length of the underside of the sender flange to the center of the float pivot. Column "3" shows the distance from the center of the float pivot to the center of the float ball.
- It will be necessary to eliminate part of the assembly for tanks measuring less than 15 1/2" (follow the steps below and refer to the Assembly Adjustment Diagram). Otherwise, you may proceed to section III.

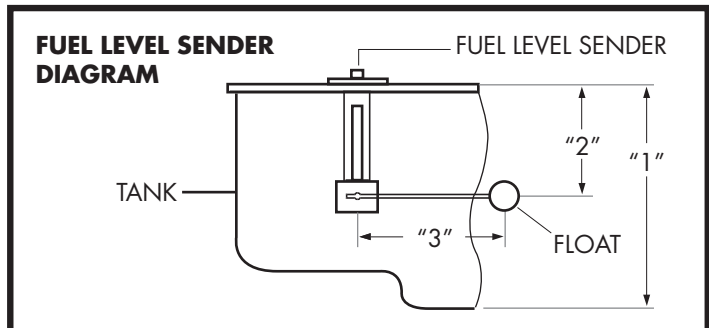

SENDER ADJUSTMENT CHART (Dimensions in Inches)

1	2	3	1	2	3	1	2	3
6.0	3.00	3.5	12.0	6.00	7.8	18.0	9.00	12.0
6.5	3.25	3.8	12.5	6.25	8.1	18.5	9.25	12.3
7.0	3.50	4.2	13.0	6.50	8.5	19.0	9.50	12.6
7.5	3.75	4.5	13.5	6.75	8.9	19.5	9.75	12.9
8.0	4.00	4.9	14.0	7.00	9.3	20.0	10.00	13.4
8.5	4.25	5.3	14.5	7.25	9.6	20.5	10.25	13.8
9.0	4.50	5.6	15.0	7.50	10.0	21.0	10.50	14.2
9.5	4.75	6.0	15.5	7.75	10.4	21.5	10.75	14.6
10.0	5.00	6.4	16.0	8.00	10.7	22.0	11.00	15.0
10.5	5.25	6.7	16.5	8.25	11.0	22.5	11.25	15.4
11.0	5.50	7.1	17.0	8.50	11.4	23.0	11.50	15.7
11.5	5.75	7.4	17.5	8.75	11.8			

AURORA SERIES GAUGES



1. From the underside of the mounting flange, remove nut "a", washer "b", and ring terminal "c"
2. Remove the two screws marked "d".
3. Remove and save (for later use) the two screws marked "e" from the plastic housing
4. Remove bracket "f" carefully from the plastic housing and re-install the two screws marked "e" into the housing loosely.
5. Move the housing up or down until the proper dimension from the Sender Adjustment Chart is met and then tighten the "e" screws securely.
6. Replace the ring terminal and its hardware.

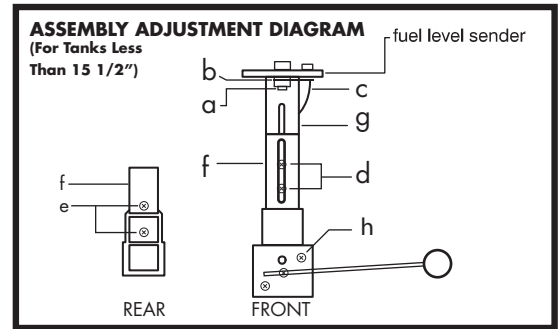

FUEL LEVEL SENDER INSTALLATION (CONTINUED)

- III. For tank depths of 16" to 23".
 1. As instructed in Section II, remove the ring terminal.
 2. Loosen the two screws marked "d" Adjust the plastic housing up or down by loosening the two screws marked "d" until the proper dimension from Table 1 is obtained, then retighten the screws. Be careful not to overtighten them.
 3. Securely re-install the ring terminal and its hardware. Once again, be careful not to overtighten.
- IV. Loosen the screw marked "h" to install the float assembly and completely remove the short piece of rod. Insert the float rod until the desired length is achieved (from column "3" length in Sender Adjustment Chart) and then tighten screw "h" securely. Any excess rod can be cut off with bolt cutters or a similar tool.

CAUTION : As shown in the Assembly Adjustment Diagram, make sure the float ball is to the right side as you face the unit when attaching the float arm to the sender body. The fuel gauge will read "FULL" when the tank is empty if you attach the float arm to the left of the sender body.

- V. To install the fuel sender assembly into the tank, refer to the Fuel Sender Installation Diagram on the right. Place the sender assembly on top of the tank to judge the proper hole placement before drilling holes into the tank.
 1. To insert the sender, mark the area to be cut open. The important part of this step is to position the float as close as possible to the center of the tank. You only get one chance to do this right, so be careful as you proceed.
 2. In the top of the tank cut a 43 mm (1.7") hole.
 3. Insert the float arm and sender body into the 43 mm (1.7") hole with the gasket in place below the flange. Make sure that the float arm is able to move freely. Find the positions of the five mounting holes, utilizing the sender flange for guidance. Either self-tapping screws or #8-32 machine screws may be used, depending on the thickness of the tank. Use drilling and tapping techniques accordingly. Be sure to use the correct hardware if threaded holes are already present.
 4. Insert the completed fuel sender assembly into the tank and apply gas-proof sealant. Thread in and tighten the 1/2" mounting screws through the holes in the sender flange and tank. Make sure they are tightened securely but be sure not to overtighten.

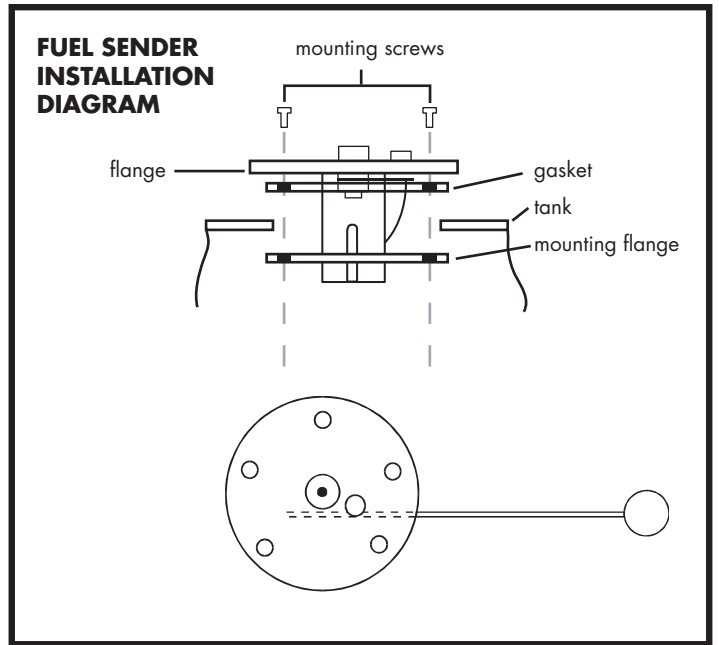

FUEL SENDER TESTING

In sending units, there are many different Ohm ranges. You can be sure that the unit is working properly with an ohm meter.

A completely empty tank will read 10 ohms. The ohm will go up as the tank is filled with fuel, reaching a maximum of 180 ohms when the tank is completely full.

G.M. : Both 0-30 and 0-90. Empty tank will read "0" ohms. The reading will go up as you fill the tank.

Stewart Warner & Ford : Empty Tank will read high on ohm range (S.W. - 240 ; Ford-73) and go DOWN as you fill the tank.

Fuel Sender* : Tank Empty - 10 ohms; full-180 ohms

*The fuel gauge will read backwards if the float arm has been installed from left to right into the pivot, re-install from right to left.

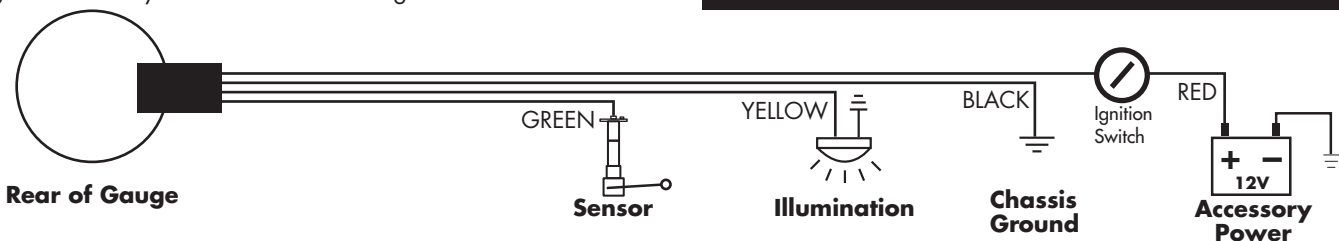

AURORA SERIES GAUGES

TEMPERATURE GAUGE

1. Find location for temperature sender. (i.e. - engine block, cylinder head, intake, or radiator)
2. Find location for gauge to be mounted on the panel and ensure that there is enough room behind the gauge for all necessary wiring.
3. Connect power and ground to appropriate locations on gauge.
4. Attach wire from sender to the gauge, as well as the gauge light to the factory light switch. Installation is complete following this step.

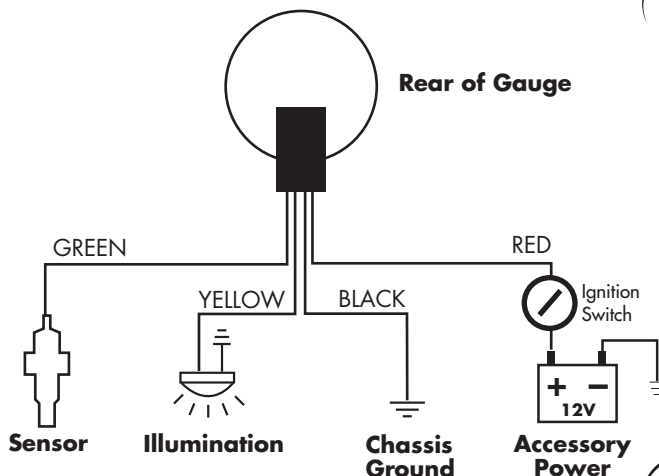

PRESSURE GAUGE

1. Find location for pressure sender. (i.e. - cylinder head or near oil filter)
2. Find location for gauge to be mounted on the panel and ensure that there is enough room behind the gauge for all necessary wiring.
3. Connect power and ground to appropriate locations on gauge.
4. Attach wire from sender to the gauge, as well as the gauge light to the factory light switch. Installation is complete following this step.

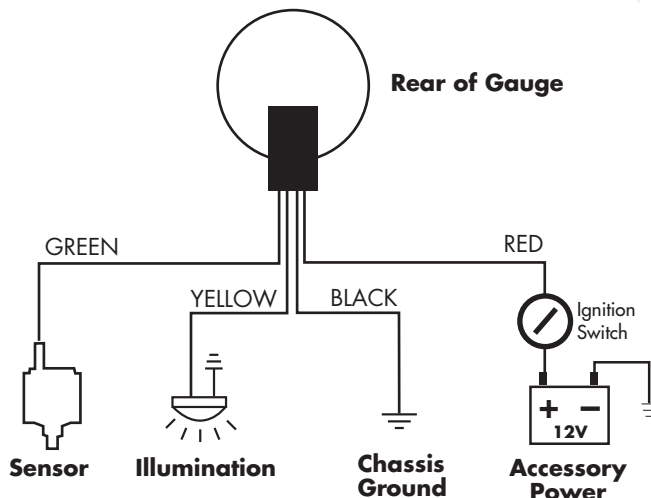

Temperature Sender	Cold	- 700 ohms
	Hot (250 degrees)	- 22 ohms
Pressure Sender	Engine Off	- 10 ohms
	Engine Running	40 psi = 105 ohms;
		60 psi = 152 ohms.

VOLT GAUGE

1. Find location for gauge to be mounted on the panel and ensure that there is enough room behind the gauge for all necessary wiring.
2. Connect power and ground to appropriate locations on gauge.
3. Wire light according to the diagram and attach to factory light switch. Installation is complete following this step.

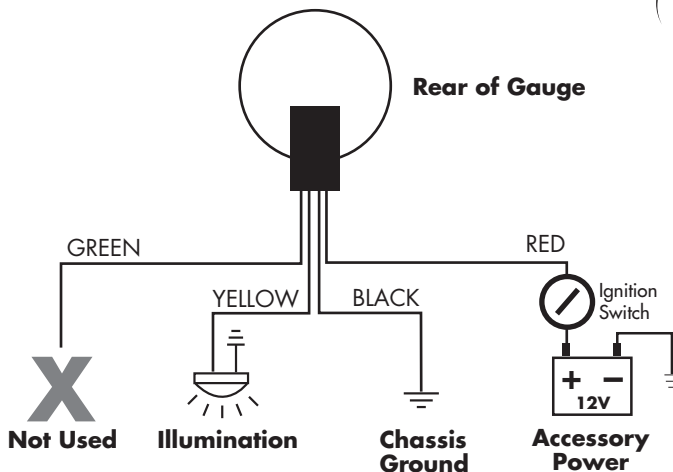

AURORA SERIES GAUGES

BOOST GAUGE

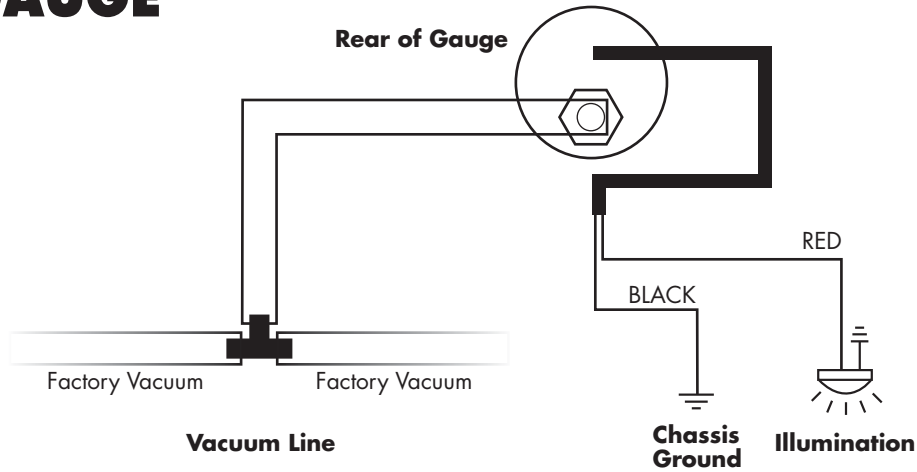

CLOCK GAUGE

To set clock, simply push black button on clock face. Clock will advance time. Release button when correct time is reached. The long hand indicates minutes, and the short hand indicates hours.

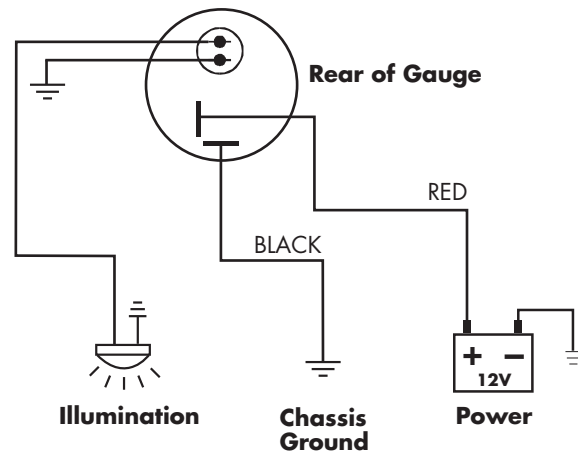

TACHOMETER GAUGE

Setting method: Connect power, press and hold the button for 5 seconds located in the rear of the gauge housing, the gauge will reset to the default settings. Press the button, with each click, the pointer moves to a single dial on the scale representing a different number of cylinders (see table below). Once the setting is chosen, stop pushing the button and with delay the needle will return to zero, the setting is memorized.

Dial Indicator	10	20	30	40	50	60	70	80	90	100
# Cylinders	3	4	5	6	7	8	10	12	14	16

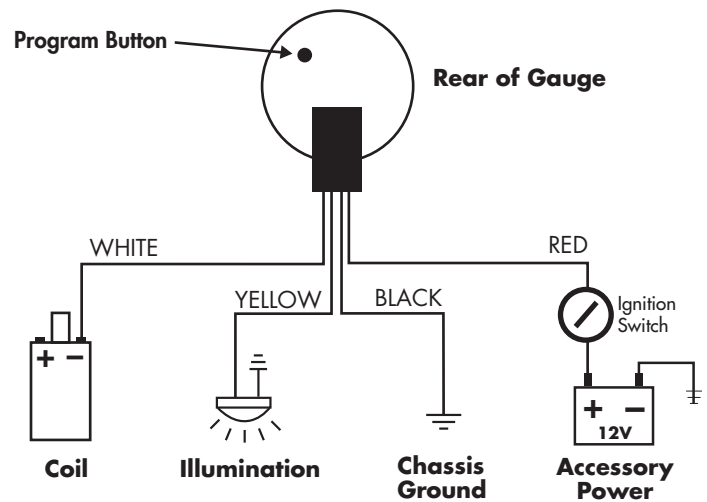

AURORA SERIES GAUGES



SPEEDOMETER GAUGE

OPERATING THE SPEEDOMETER

When the speedometer is in normal operating mode the LCD readout acts as an odometer, allowing you to display either total miles driven or trip distance. Press the button once to switch between the two.

To reset the odometer Trip Distance display to zero, simply push and hold the button in for two seconds and it will reset.

WIRING THE SPEEDOMETER

1. Find location for gauge to be mounted on the panel and ensure that there is enough room behind the gauge for all necessary wiring.
2. Connect power and ground to appropriate locations on gauge.
3. Attach wire from sender to the gauge, as well as the gauge light to the factory light switch. Installation is complete following this step.

CALIBRATING THE SPEEDOMETER

Calibration is relatively simple and can be accomplished in any of the following 3 ways:

1. Automatic calibration when driving a road with the exact distance of 1 mile clearly defined.
2. Input of the known pulse-per-mile (kilometer) for the vehicle and sensor being used with the speedometer.
3. Using a reference point for adjustment or fine tuning.

Calibration functions are accessed by pressing the button on the front of the speedometer and holding it in while ignition is started. The display will scroll through the three different methods. Let go of the button when you see the method you wish to use.

1. AUTOCALIBRATION (*AutoCL*)

1. The auto-calibration function can be used successfully only on a road with the distance of one mile.
2. Once you select the autocalibration function, the word "button" will show on the display. When you are ready to begin your calibration, press the button again and proceed to step 3.
3. Drive the distance of one mile

NOTE: As you drive the speedometer will not register or move during the calibration process.

4. When you have gone exactly one mile press the button again. If the impulse rate detected by the speedometer's microprocessor is within the calibration range limits of 500 to 399,999, the rate will be shown on the LCD display. For example, your reading might be "P16000 = Calibration Range 16000. Such display indicates that the speedometer is now perfectly calibrated to provide the most accurate display of both speed and distance. The speedometer finishes its autocalibration by moving the pointer through a full sweep and then back down to zero. If the speedometer displays the message "F 0.0" then an error occurred and you must simply restart the process again.

2. MANUAL CALIBRATION WITH KNOWN VALUE (*PULSE*)

1. If you know the exact calibration value for the vehicle and type of sensor you are using you may use that value to manually calibrate the speedometer.
2. Press and hold the button until you select the manual calibration function. Release the button and the display will start flashing a series of numbers that you can change to represent the correct calibration impulse value. For example, a number like 50000 will show on the display with each digit flashing in turn, except for the last digit on the right, which is fixed: first, the second 0 from the right; and then the third 0 from the right; then, the next 0; and finally, the 5.
3. As each number flashes just press the button to change it until the correct desired digit appears.
4. Once you have properly entered in the correct calibration value, take your finger off the button and wait. After a few seconds, the value you have entered will be down loaded into the speedometer's microprocessor and the speedometer will revert back to normal operating mode. Manual calibration process is complete at this point.

3. MANUAL CALIBRATION (FINE TUNING) (*Adjust*)

1. You can fine tune the calibration of the speedometer's analog display by using speed testing equipment.
2. Once you select the Manual Calibration Fine Tuning Function, press the button once and the word "UP" will be displayed on the LCD readout. Press it twice in rapid succession and the word "DN" (for Down) will be displayed.
3. When either "UP" or "DN" is showing, press the button again and hold it in. The pointer will move either upwards or downwards, depending on which mode you selected. The longer you hold down the button, the pointer will move faster and the shorter you hold it down, the slower it will move.
4. Once the pointer is set to the desired position, release the button and wait. The speedometer will revert back to its normal operating mode and calibration is complete.

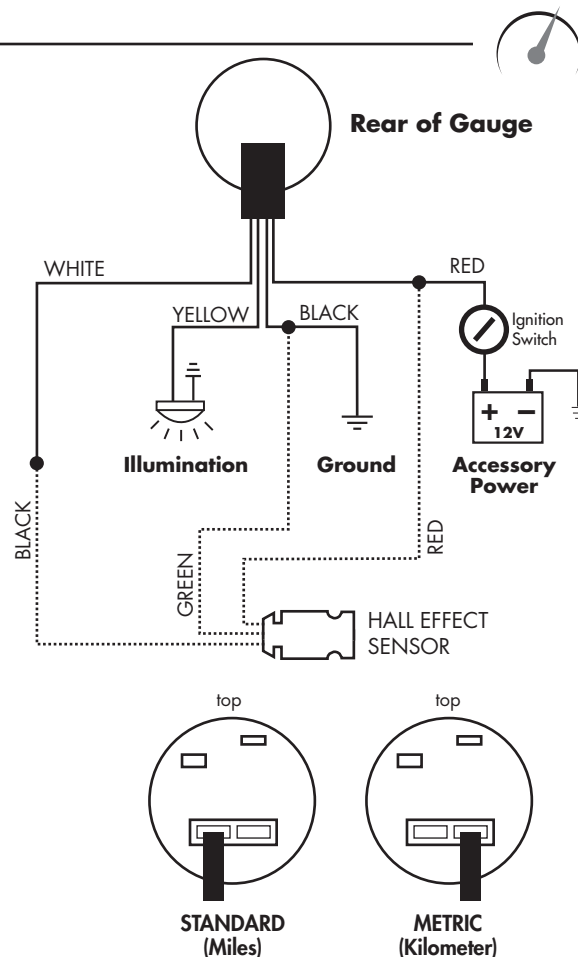

AURORA SERIES GAUGES



CUSTOM GAUGE FACE INSTALLATION



INSTALLING YOUR CUSTOM GAUGE FACES

Notice the diagram to the right. The gauges consist of 7 parts:

- Gauge Body
- Custom Gauge Face
- Needle Rest (Tach, Oil, Water, Fuel, Volts - if applicable)
- Needle
- Inner Trim Ring
- Anti-Glare Glass
- Outer Trim Ring

Please note that the order listed above is the order in which the gauge is assembled. The outer trim ring also contains a rubber seal inside that must be used to create a snug fit and prevent outside contaminants from getting into the gauge once you've assembled your gauge(s).

Expanded Gauge Diagram

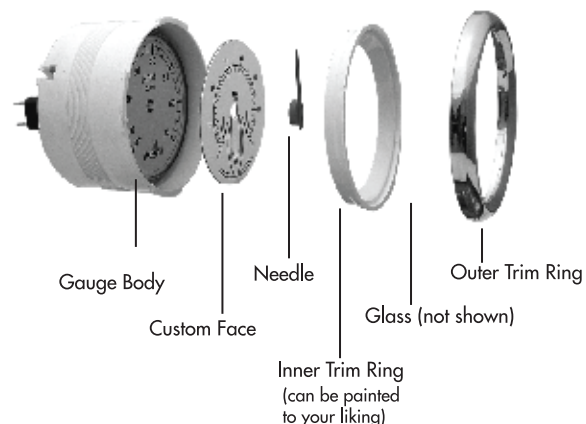

1. Remove outer trim by grasping gauge body with one hand and twisting outer trim ring. Four interlocking tabs on gauge body/trim ring hold them together.
2. Once outer trim ring has been removed, remove inner trim and glass, which simply fit inside gauge body.
3. Remove needle (clock has two needles).
4. Where applicable, remove screws.
5. Place custom face over stock gauge face, using the alignment cutouts, when applicable. (Face can be secured with thin double-sided tape if so desired.)
6. Assemble gauge in reverse order by inserting screws (where applicable) back in, replacing needle(s), inner trim ring, glass and outer trim ring.

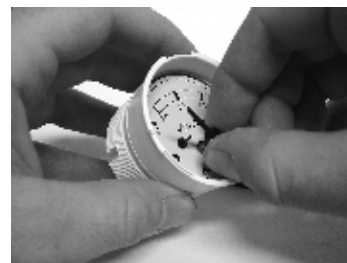

CLOCK: Note that clock needles contain small white plastic inserts. Hour hand goes on first. It is possible to push the hour hand needle on too far, thus resulting in the hour hand hitting the screws that hold the gauge face in place. To set clock, push clock button in and hold. (after clock is installed, of course)

CHECK OUT THOUSANDS OF FACES!

Go online to see our complete line of Designer Series™ Gauges, the thousands of user-submitted designs, or design your own gauge. Our easy-to-use interface makes your custom design a reality.

www.auroragauges.com

