

1. TO DRIVE SLAVE MOTORS (UP TO 5 MOTORS)
-- ALTERNATING POLARITY --

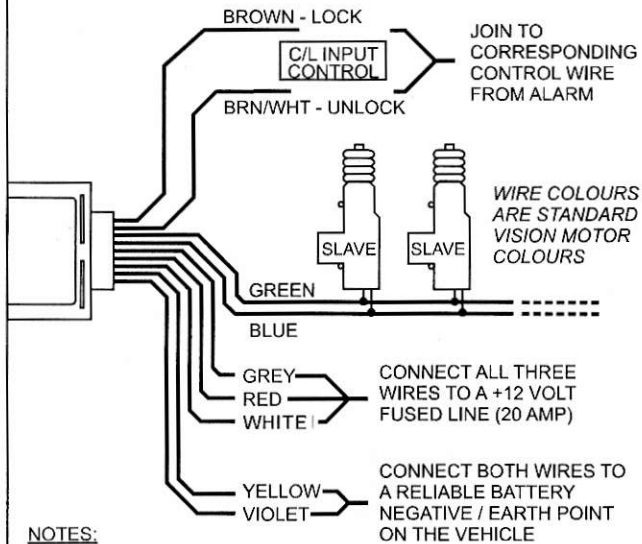

NOTES:

1. IF DOORS LOCK WHEN TURNING ALARM OFF, SWOP THE GREEN AND BLUE WIRES TO THE MOTOR AROUND.
2. THE PULSE DURATION MUST NOT BE EXTENDED TO 3.5 SECONDS

2. POSITIVE TO LOCK, POSITIVE TO UNLOCK
-- ALTERNATE POSITIVE --

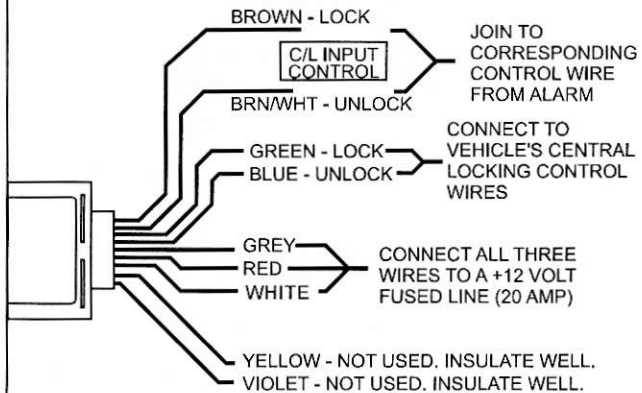

NOTES:

1. IF DOORS LOCK WHEN TURNING ALARM OFF, SWOP THE GREEN AND BLUE WIRES TO THE MOTOR AROUND.
2. THE PULSE DURATION MAY BE EXTENDED FROM 0.25 SECONDS TO 3.5 SECONDS IF REQUIRED. (REFER TO ALARM INSTALLATION MANUAL)

3. NEGATIVE TO LOCK, NEGATIVE TO UNLOCK
-- ALTERNATE NEGATIVE --

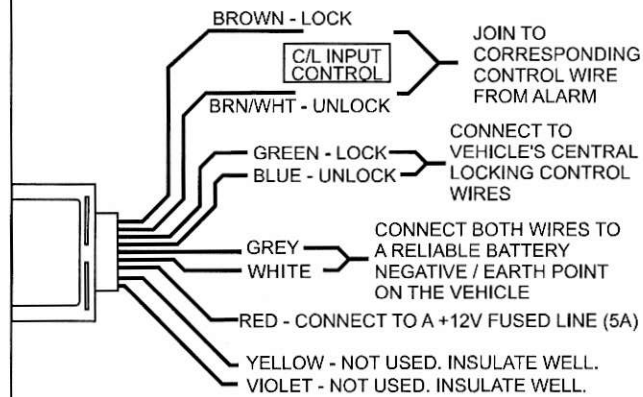

NOTES:

1. IF DOORS LOCK WHEN TURNING ALARM OFF, SWOP THE GREEN AND BLUE WIRES TO THE MOTOR AROUND.
2. THE PULSE DURATION MAY BE EXTENDED FROM 0.25 SECONDS TO 3.5 SECONDS IF REQUIRED. (REFER TO ALARM INSTALLATION MANUAL)

4. PNEUMATIC PUMP CONTROL
-- MERCEDES BENZ --

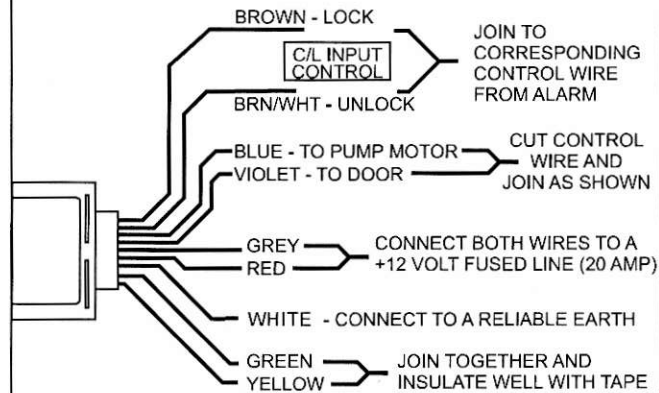

NOTE:

A LONGER PULSE DURATION IS REQUIRED FOR THE PUMPS TO OPERATE EFFICIENTLY. THE LONGER PULSE DURATION IS SELECTABLE FROM THE ALARM. (REFER TO THE RELEVANT ALARM INSTALLATION MANUAL). A JUMPER IS PROVIDED FOR THE SELECTION IN THE S-LINE 76RLi AND 77RL ALARMS.

5. BMW 3 SERIES NORMAL LOCK
-- 1993 ONWARDS --

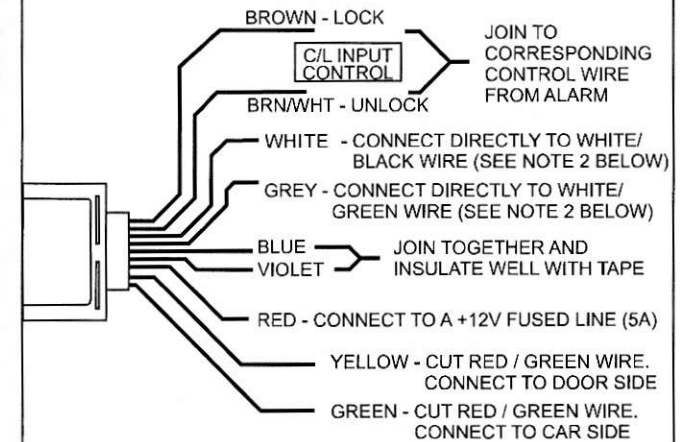

NOTES:

1. THERE ARE TWO RED / GREEN WIRES. ENSURE THAT YOU SELECT THE ONE THAT CONTROLS THE CENTRAL LOCKING.
2. THE WHITE / BLACK, WHITE / GREEN AND RED / GREEN WIRES ARE FOUND UNDER THE DRIVER'S KICK PANEL.

6. MERCEDES BENZ E-CLASS
-- 1997 ONWARDS --

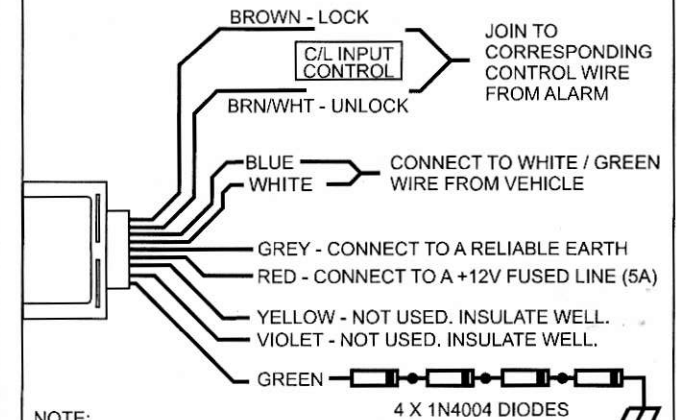

NOTE:

1. A LONGER PULSE DURATION IS REQUIRED FOR THE PUMPS TO OPERATE EFFICIENTLY. THE LONGER PULSE DURATION IS SELECTABLE FROM THE ALARM. (REFER TO THE RELEVANT ALARM INSTALLATION MANUAL). A JUMPER IS PROVIDED FOR THE SELECTION IN THE S-LINE 76RLi AND 77RL ALARMS.
2. THE WHITE / GREEN WIRE IS FOUND BEHIND THE SWITCH IN THE CENTRE CONSOLE.