

Folding & Reclining Adirondack Chair

Assembly Guide

Scan for
Assembly
Video!



BV-CHL1

*Actual Style May Vary from
the One Pictured in this Guide

HARDWARE INCLUDED

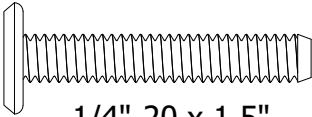
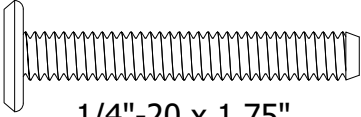
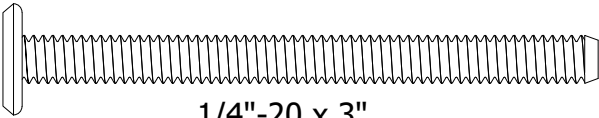
- A**  Qty: 4
#8 x 1.63"
- B**  Qty: 2
1/4"-20 x 1.5"
- C**  Qty: 4
1/4"-20 x 1.75"
- D**  Qty: 2
1/4"-20 x 3"

TOOLS INCLUDED

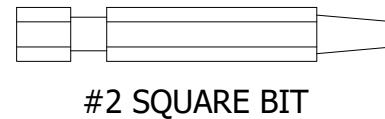
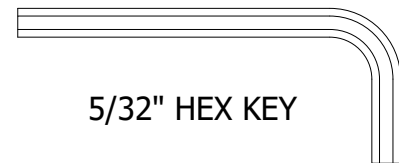

CUSTOMER SUPPLIED TOOLS

Cordless screwdriver/drill OR
Multi-bit handle for the Square Bit

IMPORTANT!

DO NOT fully tighten bolts until all bolts are started.

BACK SUPPORT SIDES

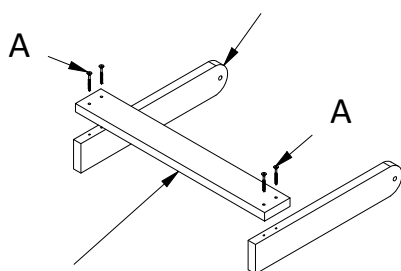

BACK SUPPORT BRACE

STEP 1

Attach Back Support Brace to Back Support Sides using (4) A Screws as shown.

ARM

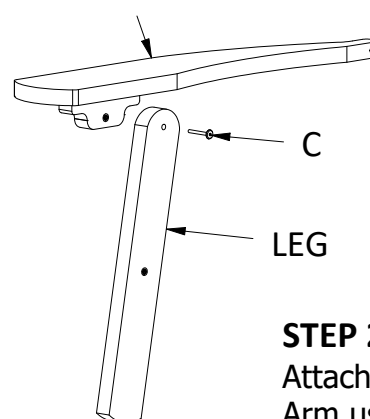

LEG

STEP 2-3

Attach one Leg to an Arm using (1) C Bolt. Repeat on other Arm/Leg.



For information on Care and Cleaning or to Register your Bahia Verde™ product, please visit www.bahiaverdeoutdoors.com.

HDK-0053

02.22.2023

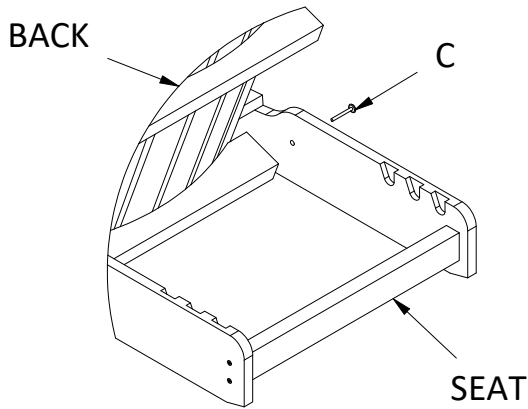

STEP 4-5

With the Back and Seat on their sides, attach one side of the Back to the Seat using (1) C Bolt as shown.

Repeat on other side.

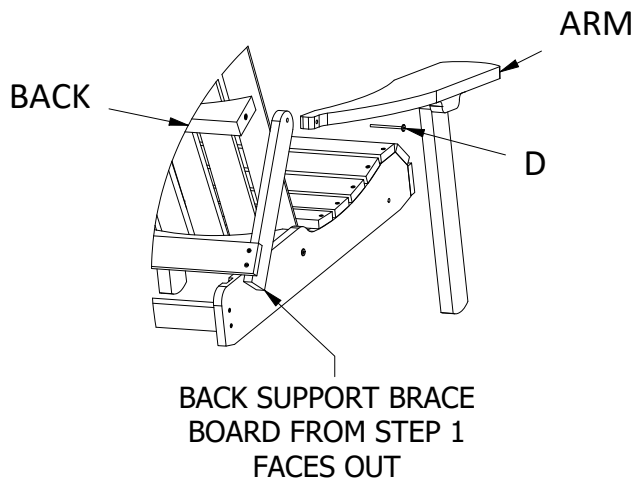

STEP 6-7

With Chair on its side. Attach Arm to Back using (1) Bolt D. Insert Bolt from Arm, through Back Support Side, into the Back. (Note: Screws face outward on Back Support Brace)

Repeat on other side.

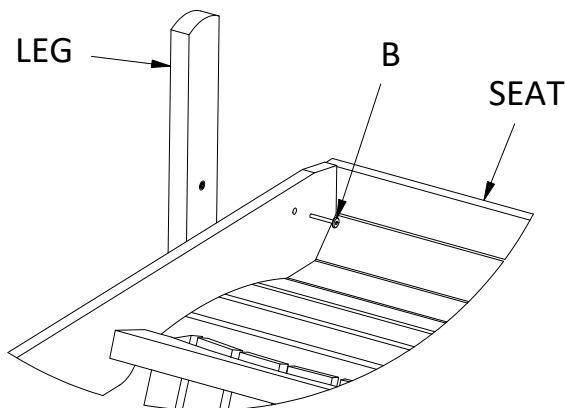

STEP 8-9

With chair still on its side, attach the Seat to the Leg using (1) Bolt B.

Repeat on other side.

IMPORTANT NOTE!

NEVER adjust the level of recline while you are sitting in the chair, or while anyone else is in the chair. Always adjust with an empty chair and ensure that the back support is completely secure in the recline slots on each side of the chair. To fold the chair, lift the back support and gently push down on the back of the chair. The chair will collapse down to the floor level.