

# Home and Garden Collection

# National Picnic Table

## Assembly Guide

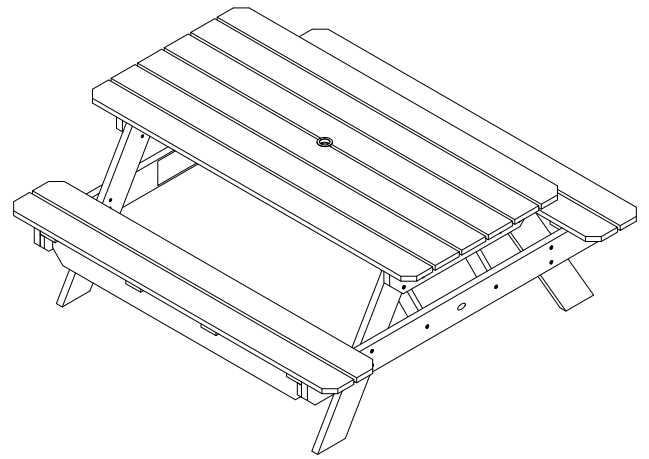

### IMPORTANT!

DO NOT fully tighten the bolts until all bolts are started. Once all bolts are inserted, go back & tighten all the bolts.

### HARDWARE INCLUDED

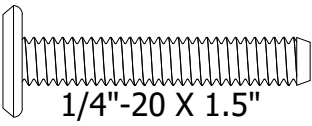
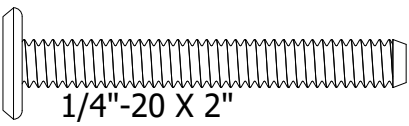
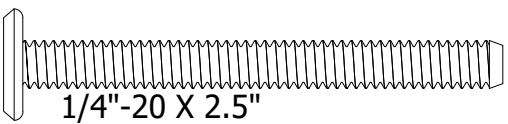
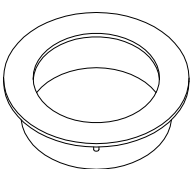
- A  1/4"-20 X 1.5" QTY 8
- B  1/4"-20 X 2" QTY 12
- C  1/4"-20 X 2.5" QTY 16
- D  2" UMBRELLA GROMMET QTY 1

### TOOLS INCLUDED



### Leg Assembly

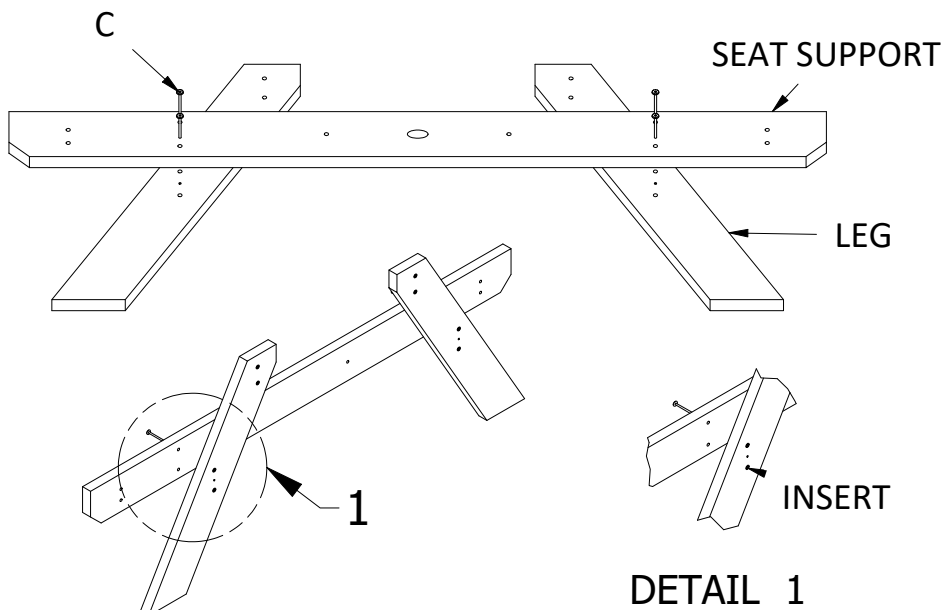

1) Start by Placing Both Legs with the Insets facing **DOWN** as shown in Detail 1.

2) Attach the Seat Support to the Legs with (4) **C** Bolts.

3) Repeat (1) and (2) for the Other Leg Assembly.



SEQUOIA  
PROFESSIONAL  
by **highwood**

For information on Care and Cleaning or to Register your SEQUOIA PROFESSIONAL product by *highwood*<sup>®</sup>, please visit [www.highwood-usa.com](http://www.highwood-usa.com).

CM-TBLSQ36  
07.12.2021

PAGE 1 OF 2

LEG ASSEMBLY

TABLE TOP

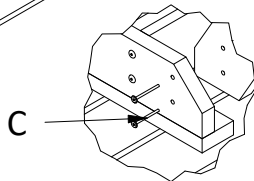
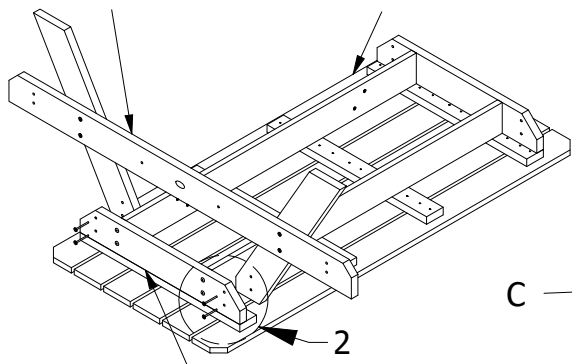

C

DETAIL 2

TABLE TOP END SUPPORT

4) Start by Placing the Table Top Facing **Down** as Shown here to the Left.

5) Attach the Leg Assembly to the Table Top End Support with (4) **C** Bolts. Ensure the Seat Support Faces the Outside of the Table as Shown to the Left.

6) Repeat (4) and (5) for the Other Leg Assembly on the Opposite Side of the Table Top.

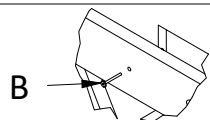

B

BRACE

DETAIL 3

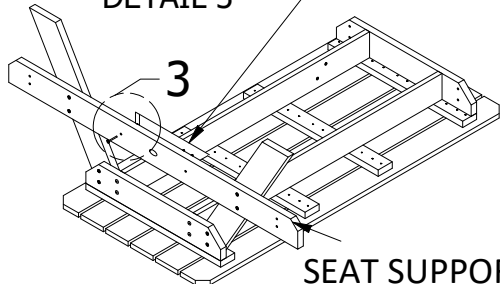

3

SEAT SUPPORT

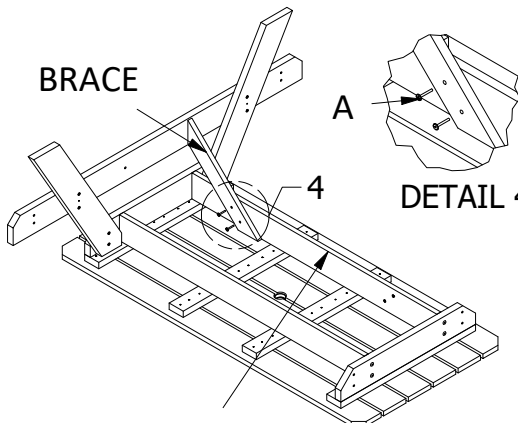

A

DETAIL 4

TABLE TOP RAIL

7) Attach the Brace to the Seat Support using (1) **B** Bolt. Reference Detail 3.

8) Attach the other end of the Brace to the Table Top Rail using (2) **A** Bolts. Reference Detail 4.

9) Repeat (7) and (8) to attach the 3 other Braces on each Corner of the Frame.

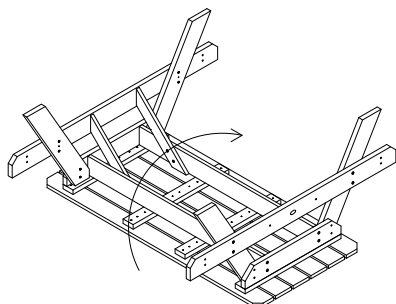

DETAIL 5

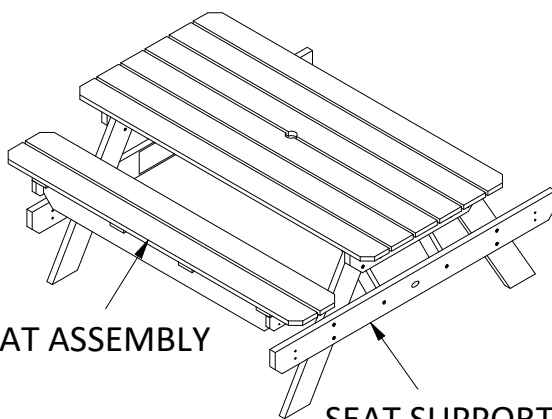

SEAT ASSEMBLY

SEAT SUPPORT

10) Once all Braces are attached, as Shown in Detail 5, Flip the Table Upright With the Help From Another Person.

11) Line Up the Seat Assembly With the Bolt Holes in the Seat Support.

12) Repeat (11) for the Other Seat Assembly.

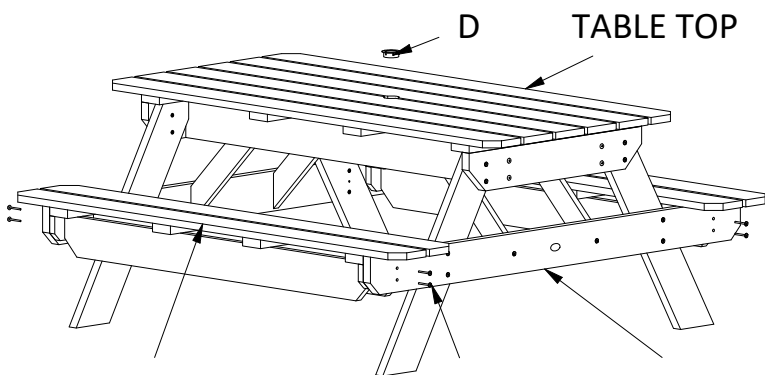

SEAT ASSEMBLY

B

SEAT SUPPORT

D

TABLE TOP

13) Attach the Seat Assembly to the Seat Support Using (4) **B** Bolts. Repeat for the Other Seat Assembly.

14) Place the Umbrella Grommet (**D**) in the Cutout of the Table Top.



SEQUOIA  
PROFESSIONAL  
by **highwood**

For information on Care and Cleaning or to Register your SEQUOIA PROFESSIONAL product by *highwood*<sup>®</sup>, please visit [www.highwood-usa.com](http://www.highwood-usa.com).

CM-TBLSQ36  
07.12.2021

PAGE 2 OF 2