



Xtreme FlipTarp Electric System for End Dumps up to 50'



Attention Dealers: Please give this owners manual to the customer when the product is delivered.

Sioux City Tarp, Inc.
5201 Harbor Drive
Sioux City, IA 51111

Custom-Built Tarps
Made in the USA

712-258-6939
SALES@SIOUXCITYTARP.COM
WWW.SIOUXCITYTARP.COM

5800-Xtreme System Contents

Product #	Qty	Description
5801	2	25' Arms
5802	1	106" Cross Tube
5803	1	Aluminum Tarp Axle
5804	1	Aluminum Wind Deflector
5805	1	Pivot Pin - Driver's Side
5806	1	Pivot Pin - Passenger's Side
5807	1	HD Coil Spring - Driver's Side
5808	1	HD Coil Spring - Passenger's Side
5809	1	Axle Bearing with Flange
5810	2	Tarp Spool Mounting Brackets
5811	1	Steel Stud Shaft
5812	1	Tarp Motor
5813	1	Rotary Switch Kit (comes boxed) (contains 9 items)
5814	1	Roll of Dual Connector Wire (80')
5815	2	90 Degree Corners (Aluminum)
5816	1	Female Plug (Vertical)
5817	2	Spring Mounting Plates
5818	2	Lower Arm Plates (Straight)
5819	2	2" Washer and Cotter Pin
5820	1	Wire Loom (12')
56118	8	Wire Clamps and Screws

Hardware (Bagged)

1108	6	1/4 Self Tapper (Tarp to Axle)
11742	6	3/8 x 2 1/4 Bolt Nut Washers (2-Spring Arm) (4 Cross Tube)
1104/1108	2	U Clamps/Screws (Cross Tube and Tarp)
1174	16	3/8 Self Tapper 1" (Spring Plate Mount)
11741	8	3/8 x 1 Bolt Nut Washers (Pivot Pin to Spring Plate Mount)



INSTALLING THE TARP AXLE:

- 1 - TARP MOTOR
- 2 - TARP AXLE MOUNTING BRACKETS
- 3 - CHROME MOTOR COVER
- 4 - 3/4" BEARING WITH FLANGE
- 5 - ALUMINUM TARP AXLE/SPOOL
- 6 - 5" X 3/4 STUD SHAFT
- 7 - RUBBER BUMPER
- 8 - 5/16 X 3/4 BOLT
- 9 - 5/16 NYLON NUT
- 10 - 5/16 X 2 1/4 BOLT
- 11 - 1/2 X 1 BOLT
- 12 - 1/2 NUT
- 13 - 5/16 X 3/4 BOLT & WASHER
- 14 - ALUMINUM WIND DEFLECTOR (optional)
- 15 - 3/8 X 1 1/2 SELF-TAPPING BOLTS (for use with wind deflector)

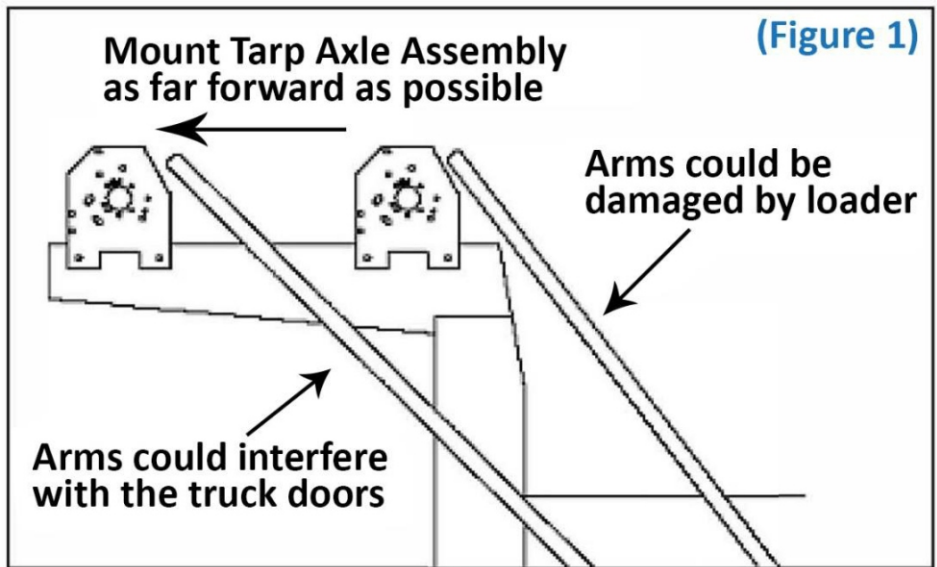
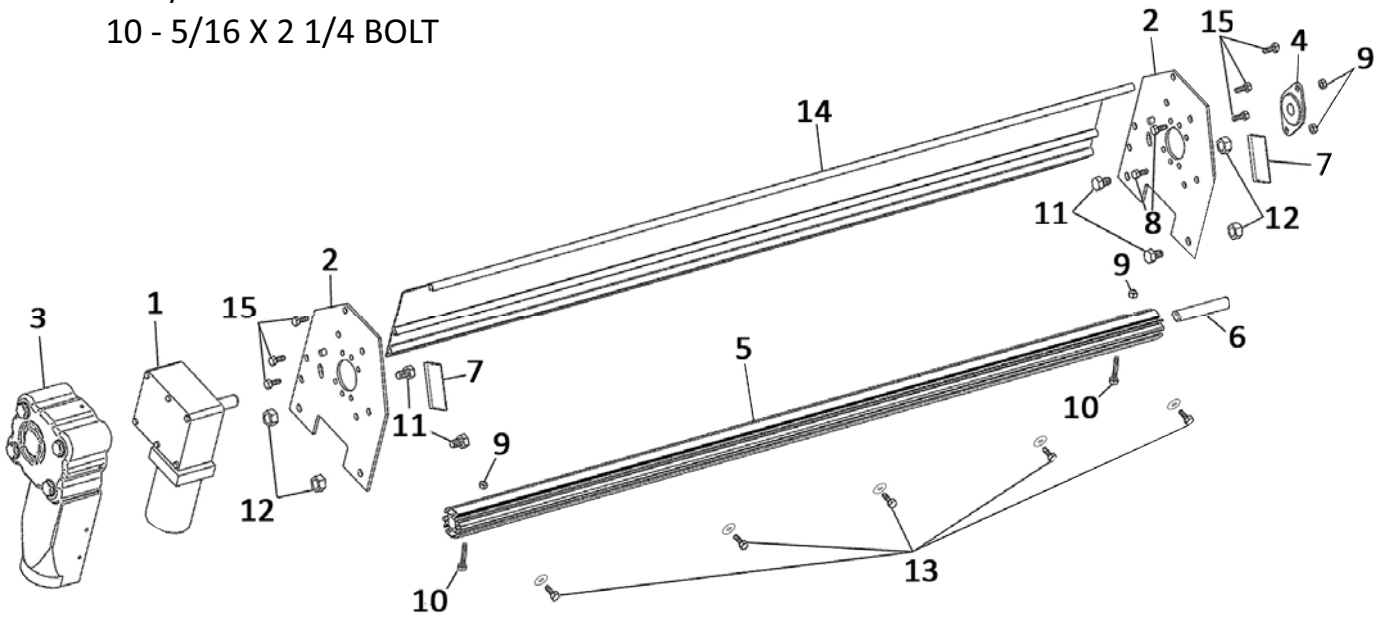

INSTALLING THE TARP AXLE (CONTINUED):

STEP 1: CHOOSING THE MOUNTING LOCATION OF THE TARP SPOOL KIT The Tarp Spool (5) and Tarp Motor (3) should be mounted on top of the cab guard, as far forward as possible to avoid damage by loaders, but not so far forward that the upper arms block the vehicle doors (see Figure 1). Bends or elbows (sold separately) can be added to the arms for more ideal positioning. **Note:** *If there is no room to mount the Tarp Axle Assembly due to exhaust stacks or vehicle design, the axle and motor will need to be mounted on the top of the side board pockets or at the front of the dump bed.*

STEP 2: INSTALLING THE MOUNTING BRACKETS

Once you have determined your mounting location, you can install the included Tarp Spool Mounting Brackets (2) or just use the brackets as a template to drill directly into the frame of the truck. **Note:** *Make sure to factor in the space needed between the tarp axle and the roof of the cab guard to allow the entire tarp to roll up effectively.*

STEP 3: MOUNTING THE TARP MOTOR AND TARP SPOOL

Measure from the inside of one mounting bracket to the inside of the other and cut the Tarp Axle 1" shorter than that length. The axle is predrilled with holes $\frac{3}{4}$ " from the ends. After cutting, drill a new $\frac{3}{8}$ " hole through the axle on the side that you cut, $\frac{3}{4}$ " from the end (drill in one of the round-bottomed slots, not in one of the threaded slots). Slide one end of the Tarp Axle over the motor output shaft and secure with a $\frac{5}{16}$ " bolt (10), washer, and nut (9). Attach the Axle Bearing (4,8,9) to the mounting bracket opposite the motor. Slide the Stud Shaft (6) through the Axle Bearing into the Tarp Axle. Line up the holes in the Tarp Axle to the hole in the Stud Shaft and secure with $\frac{5}{16}$ " bolt (10), washer, and nut (9) and tighten the axle bearing set screws to secure the stud shaft's position inside the axle bearing.

(OPTIONAL) STEP 4: INSTALLING THE WIND DEFLECTOR

Measure the distance between your mounting brackets, and cut the Aluminum Wind Deflector (1) to the proper length and attach it to the Tarp Spool Mounting Brackets using the included six self-threading bolts (17)



WIRING THE TARP MOTOR:

The motor must be wired with the provided 6 or 8 Gauge Wire. Use of smaller wire will cause your tarp system to operate slowly and possibly overheat. **Suggestion:** Run some 3/4" EMT conduit down the front of the body and back along the frame rail to improve safety and aesthetics!

1. Mount the included switch bracket in a safe, convenient location, clear of anything that might bump the switch into the "On" position or prevent the circuit breaker from popping. See figure.

2. Unroll the included wire. Run the wire down from the tarp motor, then along the bottom of the box, around the hinge (leave enough slack to avoid binding or pinching during the operation of the lift) and into the cab where the switch is mounted. For trailers, it is recommended to use a plug set rated to 50 amps or higher so you can easily disconnect between the cab and the dump box.

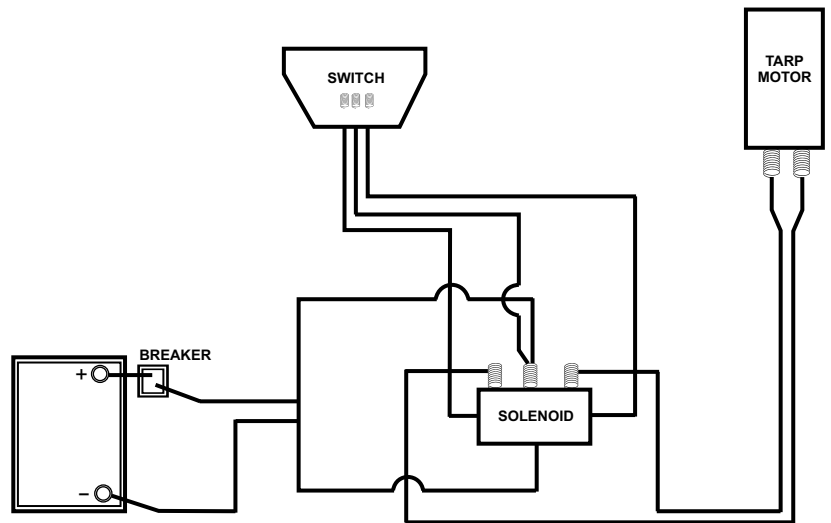

3. Cut off the extra wire, but leave enough to easily connect to the switch. Set aside one of the leftover wire to later run from the cab to the positive (+) post of the battery or starter. **WARNING: DO NOT CONNECT AT THIS TIME!** Run another piece of wire from the cab to a ground screw on the firewall or other suitable grounding location.

4. Connect the wires leading from the switch to the motor using the piece leading from the cab to the grounding location.

5. Connect the positive wire to the battery terminal marked (+) and check to see that the system is operating as indicated on the switch bracket. To wind up the tarp, the tarp roller bar should spin counter-clockwise (viewing it from the driver's side of the cab.) If not, swap the two wires connected to the motor. If the roller bar rotates clockwise, any debris on the tarp will be rolled up in it and possibly cause damage.



INSTALLING THE PIVOT PINS:

- A:** Resting location of deployed cross tube
- B:** Center point of the motor shaft (location of mounted axle)
- C:** Pivot point



Finding the placement for the underbody assembly (pivot point). To find the placement for the under body assembly you must find the center point of the dump body.

Using two tape measures, hook the end of the one to the tarp axle and the end of the other to the very top rear corner to the tailgate and measure toward the center at the bottom of the body.

At the distance where the tape measures cross reading the same measurement is the center point of the flip tarp system.

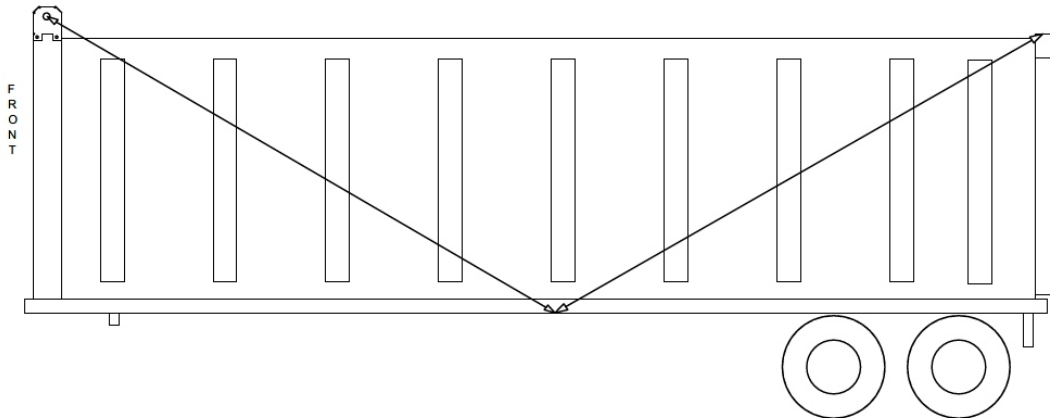

**Diagram 1 and Diagram 2: Two different figurations to find Center Point*



INSTALLING THE PIVOT PINS, Cont.:

1. Measure your dump body from Point A to Point B Divide that number by two to find the halfway point.
 2. Measure along the edge of the dump body from Point A towards Point B and mark the halfway point between A and B.
 3. Copy the halfway mark on the bottom of your bed, either by measuring from the front or back of the bed or by using a level or plumb line. This is Point C.
 4. Measure from Point A to Point C and then measure from Point B to Point C. These measurements should be equal. If they are not, shift Point C left or right until the distance between C and A is equal to the distance between C and B, then mark it. This will be your pivot point.
- * Depending on where you mount the tarp axle, Point C will not always be located in the exact middle of the dump bed.
- *Make sure the operation of the tail gate will not be inhibited by the position of the cross tube at Point A.
5. **Repeat steps 1-4** on the other side of the dump bed and verify that all measurements match on both sides.

6. Hold the pivot pin to the bottom of the dump bed where you intend to mount it.
7. Use the pivot pin holes to mark your drilling locations (You can also weld the pivot pins to the bed if you prefer.)
8. Bolt the spring mounting plate to the box/trailer using the 3/8" x 1" self tapping bolts.
9. Repeat for opposite side.
10. Next, bolt the pivot pin to the spring mounting plate using 3/8" x 1" bolts/nuts/washers.

* Be sure the pin is oriented correctly. **See Figure 3.**

11. Slide springs onto pivot pins, then install the Lower Arm Plates so they are pointing towards the rear of the box/trailer.

*Springs are labeled Driver's Side/Passenger Side. Spring placement is critical.

Install washer and cotter pin to hold assembly together.

12. Slide an Arm onto the Lower Arm Plate until the corner rests on the desired landing point at the back of the dump body (Point A). If the arm is too long cut it to the correct length. Cut both arms to the same length. Install Cross Tube corner connectors and bolt together.

13. Once pivot pins and springs are installed, slide arms onto Lower Arm Plates. Drill hold through Arm and Lower Arm Plate. Bolt with 3/8" x 2 1/4" bolt/nut/washer.

Repeat for opposite side.

DRIVERS
SIDE
ORIENTATION

Figure 3

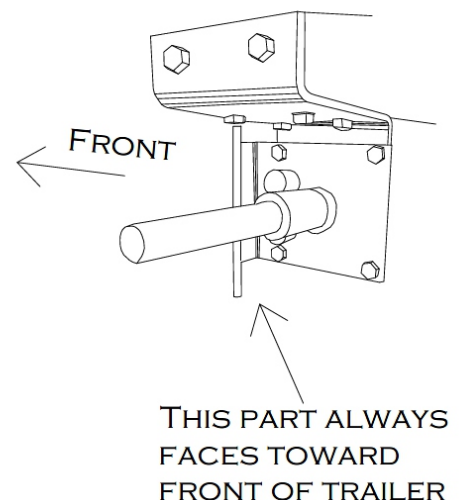

INSTALLING THE TARP

The tarp axle has several ways of attaching a tarp. You can screw bolts through the tarp grommets into the threaded slot of the axle. The most common method is to use the threaded slot, which allows you to securely fasten the tarp at the grommets locations. The included hardware assumes this method. See **Figure 5** for more information.

FIGURE 5

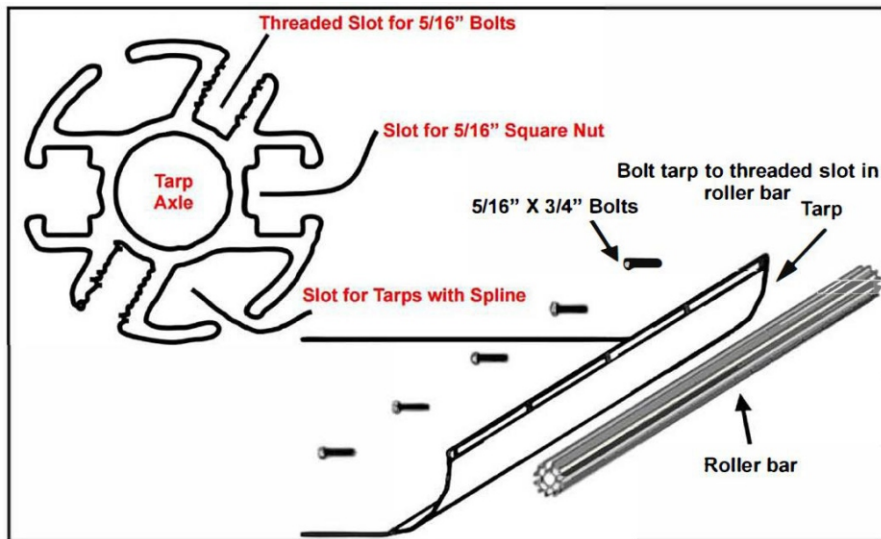

1. Line the front tarp grommets up with one of the threaded slot in the axle.
2. Attach the tarp to the front axle with 5/16" x 3/4" bolts and washers.
3. Slide the cross bar through the pocket in the back of the tarp. Drill 3/8" hole through cross bar and corner connector. Fasten together.
4. Center tarp on rear cross tube. Secure tarp to rear cross bar with U-Clamps and Screws (x2).

CONGRATULATIONS ON INSTALLING YOUR NEW FLIPTARP ELECTRIC SYSTEM!



FRONT OF TRAILER

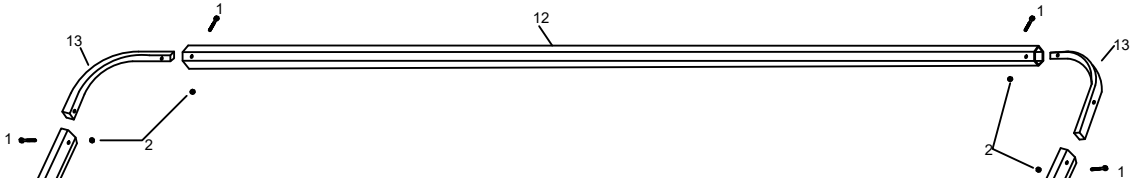

- 1 3/8" x 2 1/4" Bolts
- 2 3/8" Nylock nuts
- 3 3/8" x 1" Self tapping bolts
- 4 3/8" x 1" bolts
- 5 3/8" x 3" cotter pins
- 6 2" flat washer
- 7 Lower Arm Plates
- 8 Drivers Side Spring
- 8.1 Passenger Side Spring
- 9 Pivot Pins
- 10 Spring Mounting Plates
- 11 Tarp Arms
- 12 106" Cross Tube
- 13 90 degree corner

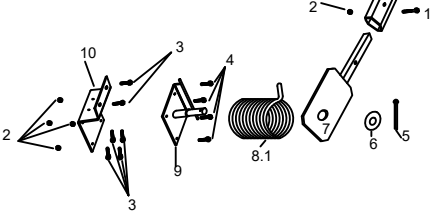
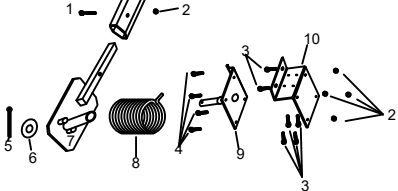

SIoux CITY TARP, Inc



SIoux CITY TARP, Inc

Sioux City Tarp, Inc. 5201 Harbor Drive, Sioux City, IA 51111

712-258-6939 SALES@SIouxCITYTARP.COM WWW.SIouxCITYTARP.COM