

ADCRAFT®



HDS-1200W Hot Dog Steamer

This manual contains important information regarding your *Admiral Craft* unit. Please read this manual thoroughly prior to equipment set-up, operation and maintenance. Failure to comply with regular maintenance guidelines outlined in this manual may void the warranty. MUST READ!!!

WARNINGS

- Do not touch any hot surfaces
- Do not immerse unit, cord or plug in liquid at any time
- Unplug cord from outlet when not in use and before cleaning
- Plug only into a 3-hole grounded electrical outlet
- Do not operate unattended
- Do not use this unit for anything other than intended use
- Do not use outdoors
- Always use on a firm, dry and level surface at least 12" from walls or any other obstruction
- Do not use if unit has a damaged cord or plug, in the event the appliance malfunctions, or has been damaged in any manner
- Keep children and animals away from unit
- Any incorrect installation, alterations, adjustments and/or improper maintenance can lead to property loss and injury. All repairs should be done by authorized professionals only
- Ensure that the designated power supply is adequate for continual usage and the voltage is correct

TO INSTALL

1. Remove unit from the box and remove all parts.
2. With the operator side facing you (dial to the left) set it down on a flat sturdy surface.
3. Open the top flaps of the unit and remove the parts and packing foam. Put the parts to the side.
4. Slide in glass windows for both the back and front of the unit.
5. Pour six quarts of water into the base of the unit to cover the heating element. **DO NOT OVERFILL.** It is recommended that you use hot water to reduce preheat time. Make sure valve drain cap is screwed tightly closed.
6. Once the water is in, place the perforated rectangular base on the left side of the unit.
7. Place the square base plate with the control lever on the right side of the unit.
8. Slide the partition piece into the left slots to separate the hot dog and bun sections of the steamer.
9. Place the hot dog rack to the of the left side compartment. Make sure the rack is standing on its feet to allow proper circulation of steam.
10. Place the bun rack on the right side in the bun compartment.
11. Place lid beam in the middle of the unit so the lids rest on the edges of the beam.
12. Place lids down on unit edges and swing closed. Adjust lid beam to fit if needed.
13. Ensure that the unit is plugged into a grounded and properly-sized electrical outlet to minimize shock or fire hazard. Refer to the electrical requirements on the serial tag located on the operator side of the unit.
14. Turn the switch on and set the thermostat control on the highest setting until steam is generated.
15. For normal operation, set the thermostat control in the center of the range between the highest and lowest temperature (130 degrees).
16. Place hot dogs in the small compartment and buns on the wire rack in the large compartment. Arrange the hot dogs and buns so that there is enough room for circulation of steam.
17. To control the amount of steam in the bun compartment, use the adjustable humidity control lever located in the bun compartment under the wire rack.
18. Keep lids closed when not serving.
19. Add hot water when necessary to maintain the water level. Do not allow the unit to burn dry. If you accidentally run it dry, turn off and allow the unit to completely cool before adding water. Adding water to a dry unit while it is still hot could cause damage to the elements.

CLEANING – NOTE: To maintain cleanliness and increase service life, the hot dog steamer should be cleaned daily. Do not immerse the unit in water or any other liquid. If liquid enters the electrical compartment it may cause a short circuit or electrical shock.

1. Disconnect the power cord from the electrical outlet.
2. Allow the unit to cool down completely.
3. Remove any remaining hot dogs and buns.
4. Drain the water using the drain pipe located on the operator side.
5. Detach all removable parts including the bun rack, perforated trays, steam control lever, partition and glass panels. Thoroughly clean the unit. Although stainless steel is corrosion resistant, for longevity purposes the unit should be cleaned after every use.

TROUBLESHOOTING

Troubles listed are for reference. If any fault occurs, please discontinue use. Do not attempt to repair yourself. This will void the warranty.

Problem	Cause	Solution
Condensation on glass partition	Cool air striking the warm surface of the steamer	Avoid placing the unit against cool drafts of air
Hot dog casing burst	Too much steam is being generated	Reduce the thermostat control to a lower setting.
Buns too soggy	Too much steam is being generated	Adjust the steam control level
Buns too dry	Too much steam is being generated	Adjust the steam control level

Hot Dog Steamer HDS-1000W , HDS-1200W Circuit diagram

1. 0kW/120V/50-60Hz

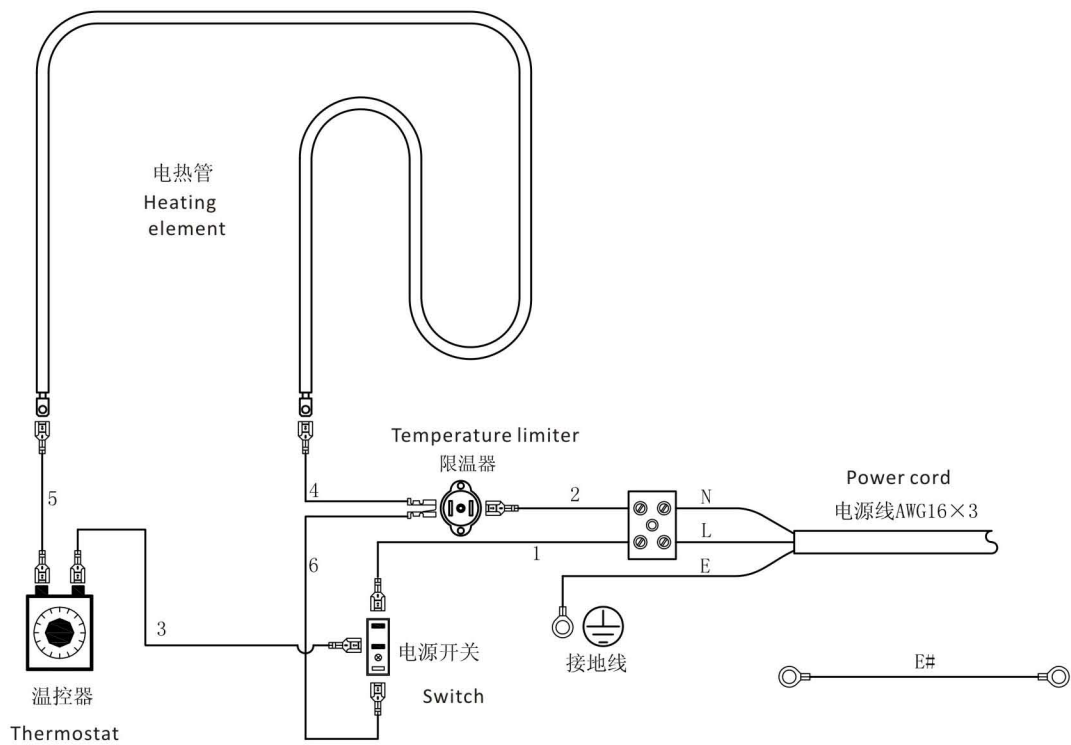
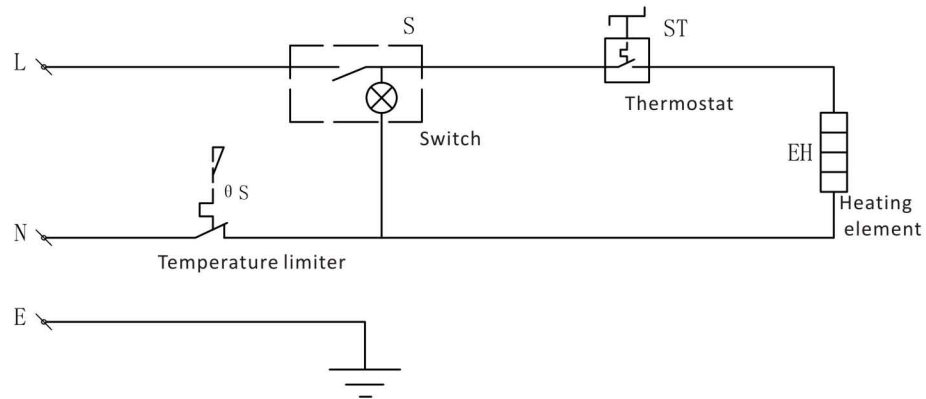

HDS-1000W
HDS-1200W

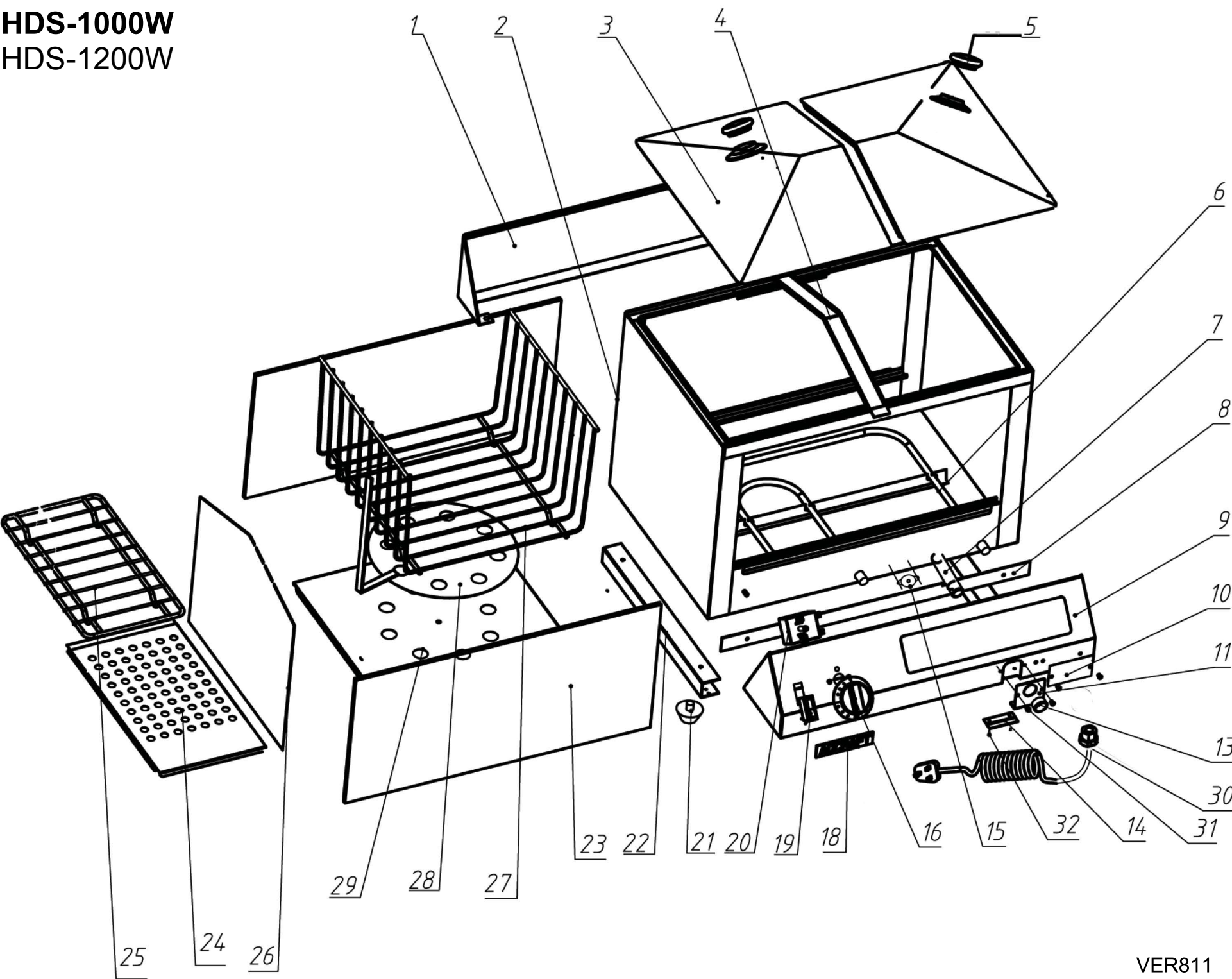

Hot Dog Steamer - HDS-1200W

Reference Number	Description
1	Rear Panel
2	Body Shell
3	Lid with Handle
4	Lid Support
5	Bakelite Handle
6	Heating Element
7	Drainage Pipe
8	Control Box Cover Plate
9	Control Box Cover Plate
10	Warning Plate
11	Drainage Cover Plate
13	Drainage Plug and Gasket
14	Drainage Cover Plate Fixture
15	Manual Thermal Limiter
16	Knob with Bottom Plate
18	Logo
19	On/Off Switch with light
20	EGO Thermostat
21	Rubber Foot
22	Body Support Rack
23	Glass
24	Hot Dog Rack
25	Small Layer Plate
26	Separate Plate
27	Bread Basket
28	Anti-Leakage Plate
29	Big Layer Plate
30	Power Cord and Strain Relief
31	S/S Screws
32	Rivet

ACE Equipment One Year Limited Warranty

Admiral Craft Equipment Corp. (ACE) warrants its equipment against defects in materials and workmanship, subject to the following conditions:

ACE Equipment is warranted for one year, effective from the date of purchase by the original owner. A copy of the original receipt or other proof of purchase is required to obtain warranty coverage. This warranty applies to the original owner only, and is not assignable.

Should any product fail to function in its intended manner under normal use within the limits defined in this warranty, at ACE's discretion, such product will be repaired, replaced with a refurbished unit, or replaced with a new unit by ACE, after defective unit has been inspected and defect has been confirmed. ACE does not assume any liability for extended delays in replacing any item beyond its control. This warranty does not apply to rubber and non-metallic synthetic parts that may need to be replaced due to normal usage, wear or lack of preventative maintenance.

This warranty covers products shipped into the 48 contiguous United States, Hawaii, and metropolitan areas of Alaska and Canada. Warranty coverage on products used outside the 48 contiguous United States, Hawaii and metropolitan areas of Alaska and Canada may vary. Contact ACE for details at 1-800-223-7750

The following conditions are not covered by warranty:

- Equipment failure relating to improper installation, improper utility connection or supply and problems due to improper ventilation.
- Equipment that has not properly been maintained, damage from improper cleaning, and water damage to controls.
- Equipment that has not been used in an appropriate manner, or has been subject to misuse, neglect, abuse, accident, alteration, negligence, damage during transit, delivery or installation, fire, flood, riot, or act of God.
- Equipment that has the model number or serial number removed or altered.
- Equipment on which the security seal has been broken.

If the equipment has been changed, altered, modified, or repaired without express written permission from ACE, then the manufacturer shall not be liable for any damages to any person or to any property, which may result from the use of this equipment thereafter.

This equipment is intended for commercial use only and this warranty is void if equipment is used in other than a commercial application.

For warranty and non-warranty related issues, technical support, purchase replacement parts and warranty registration visit www.admiralcraft.com. Please have your model number, serial number and proof of purchase ready. It is not necessary to contact the place where you originally purchased your product from.

“THE FOREGOING WARRANTY IS IN LIEU OF ANY AND ALL WARRANTIES EXPRESSED OR IMPLIED INCLUDING ANY IMPLIED WARRANTY OF MERCHANTABILITY OR FITNESS FOR PARTICULAR PURPOSES AND CONSTITUTES THE ENTIRE LIABILITY OF ACE. IN NO EVENT DOES THE LIMITED WARRANTY EXTEND BEYOND THE TERMS STATED HEREIN.”