



Catálogo:
CATERING

Capítulo
COCCIÓN

Artículo:
CPG9-05 NC LPG 230V 1N

Código:
19005973

ESQUEMA - DIMENSIONES

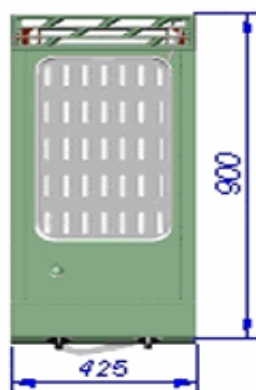
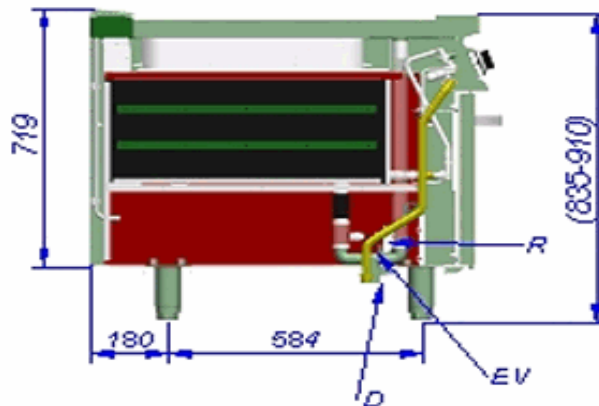
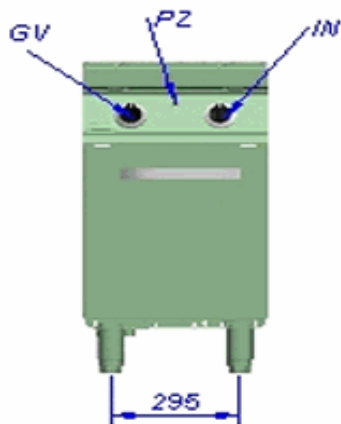

GV: Grifo válvula
IN: Grifo agua
PZ: Piezoeléctrico
D: Desagüe
EV: Electrovalvula
R: Regleta

GV: Tap valve
IN: Filling switch
PZ: Piezoelectric
D: Drainage
EV: Electric valve
R: Electric connection