

ROLLING BIG POWER

STEALTH POWER™

RUNNING BOARDS

INSTALLATION GUIDE

INSTALLATION COVERS
PART# RBP-216-SP-XD

FOR APPLICATIONS:
2009-2018 RAM 1500 CREW CAB





Your Complete Satisfaction is Our Number One Goal at Rolling Big Power - your satisfaction is why we're in business. If for any reason your experience with our product was anything less than amazing, please reach out to us. We'd love to have the opportunity to provide the product experience and service you deserve.

**For Installation Instruction videos visit our YouTube page at:
<https://www.youtube.com/user/rollingbigpowertv>**



STOP. DO NOT RETURN TO THE STORE. WE CAN HELP. QUESTIONS OR PROBLEMS, OUR TEAM OF PROFESSIONALS ARE HERE TO HELP.



CALL TOLL FREE 1-877-519-9090, MON-FRI: 8:00AM - 5:00PM PST

APPLICATIONS:

2009-2018 RAM 1500 CREW CAB

TOOLS REQUIRED

- 5 MM ALLEN WRENCH
- 13 MM SOCKET AND WRENCH
- 10 MM COMBINATION WRENCH
- ELECTRIC DRILL
- 10 MM NUT DRIVER TIP
- RAZOR BLADE
- RTV SILICONE
- 50/50 MIX OF ISOPROPYL ALCOHOL AND WATER
- 1" WIDE MASKING TAPE
- MEASURING TAPE
- TORQUE WRENCH



CONTENTS

ENGLISH

Product Technical Specifications	04
Product Packing List	05
Installation	07
Warranty Information	14

PRODUCT TECHNICAL SPECIFICATIONS

Rated Voltage: 12V

Load Rating: 600 lbs per side

Gross Weight: 55 lbs

Horizontal Extension: 6.7"

(Horizontal distance between the edge of power board and the vehicle door when the board extends)

Step Height: 14.8"

(Vertical height difference between the edge of power board and the vehicle door while board extending.)

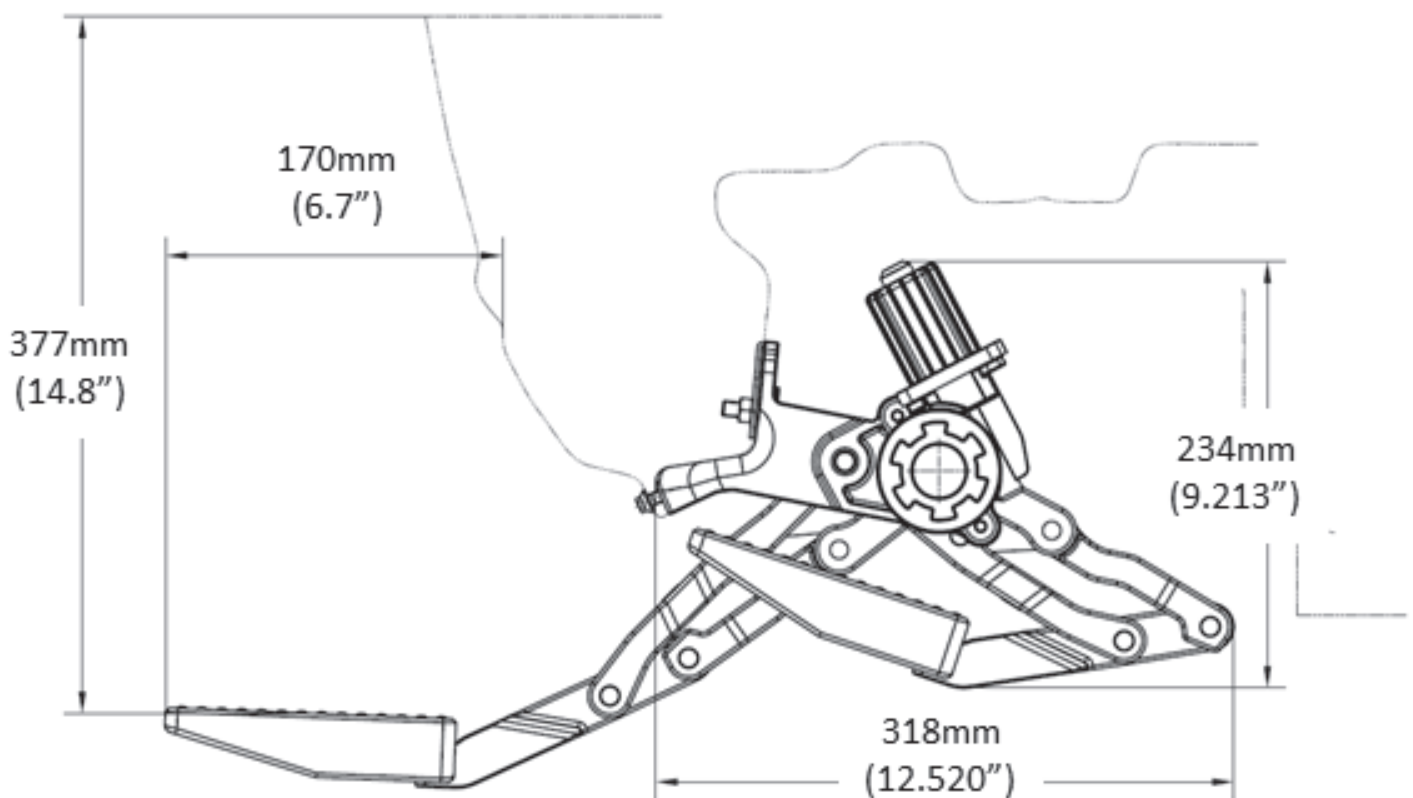





Extended drop = 2.44"

WARNING: Keep a minimum of 10" safe distance while the Stealth Power™ Running Board is operating to avoid any personal injury or damage to the running boards. Stealth Power™ Running Boards are not designed to provide vehicle body protection. Components can be damaged by hard impact or contact with foreign objects.

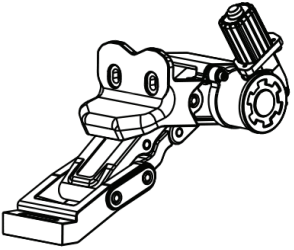
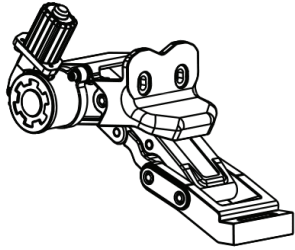
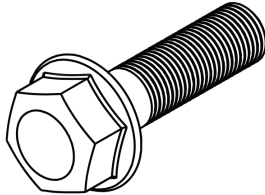
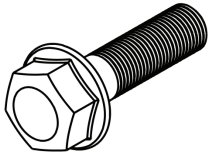
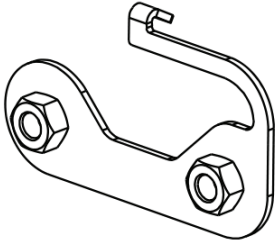

Stealth Power™ Running Board Parts List

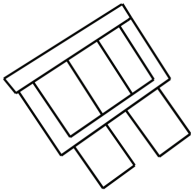
Please verify that all listed components were included in your package. If not, please call our team at 877-519-9090 for assistance.

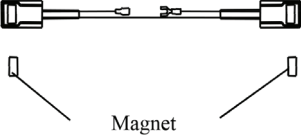
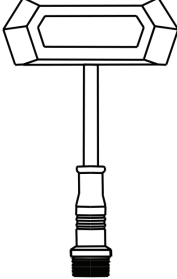
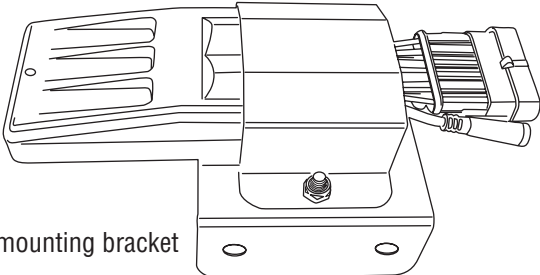
 <p>Left Front Motor Linkage 20x1 Left Rear Motor Linkage 20x1</p>	 <p>Right Front Motor Linkage 20x1 Right Rear Motor Linkage 20x1</p>	 <p>Hexagon Flange Bolt x8</p>	 <p>Hexagon Flange Bolt x1</p>
 <p>Connecting Bracket 10x5 (Two of them are in reserve.)</p>	 <p>Socket Cap Screw x8</p>	 <p>20A Fuse x2</p>	 <p>Hexagon Flange Bolt x8</p>
 <p>Magnet</p> <p>Wired Magnetic Induction Module x2 Magnet x4</p>	 <p>LED Lamp Module x4</p>	 <p>Controller mounting bracket</p>	

PRODUCT PACKING LIST

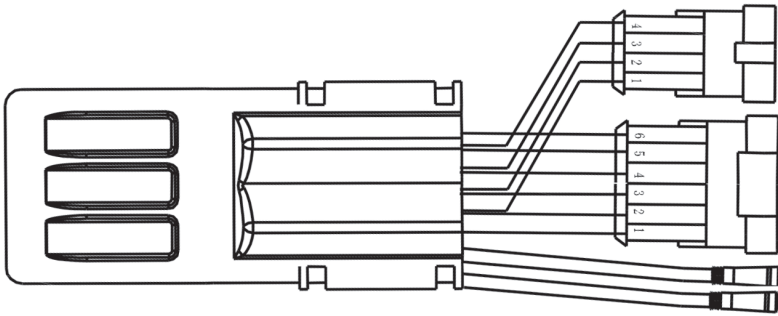

Notice: As shown in the picture, there is a four-conductor plug, a six-conductor plug, a black two-conductor plug, and a red two-conductor plug.

Controller Assembly

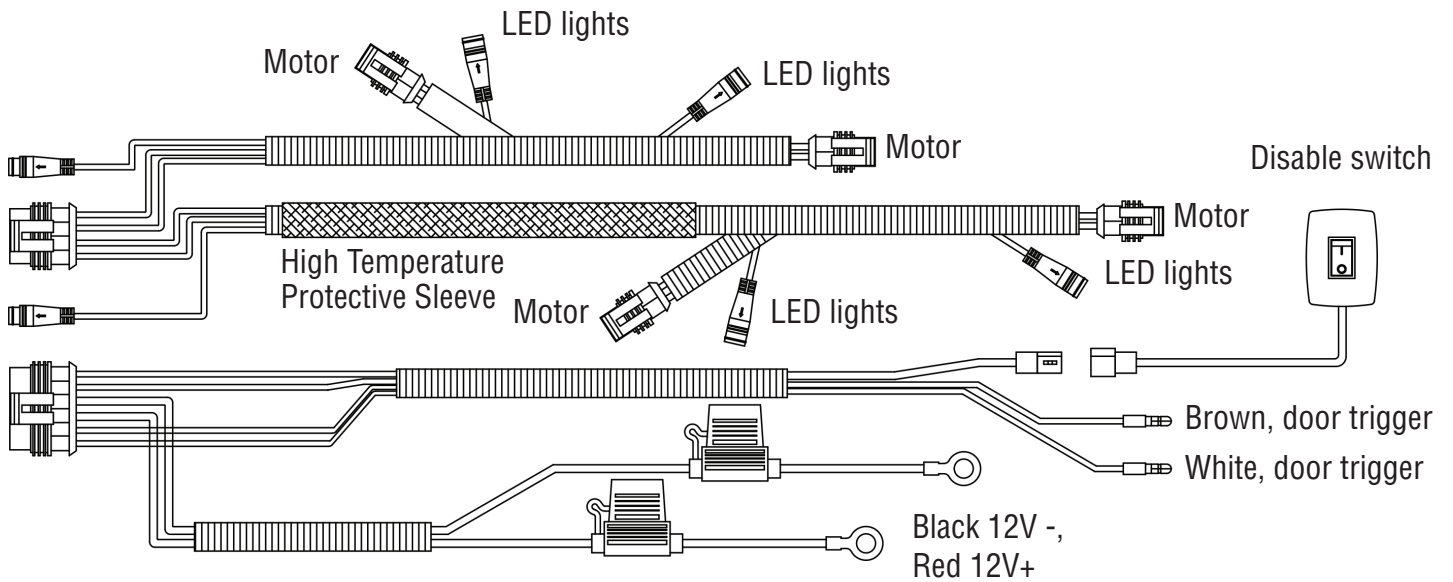

INSTALLATION INSTRUCTIONS

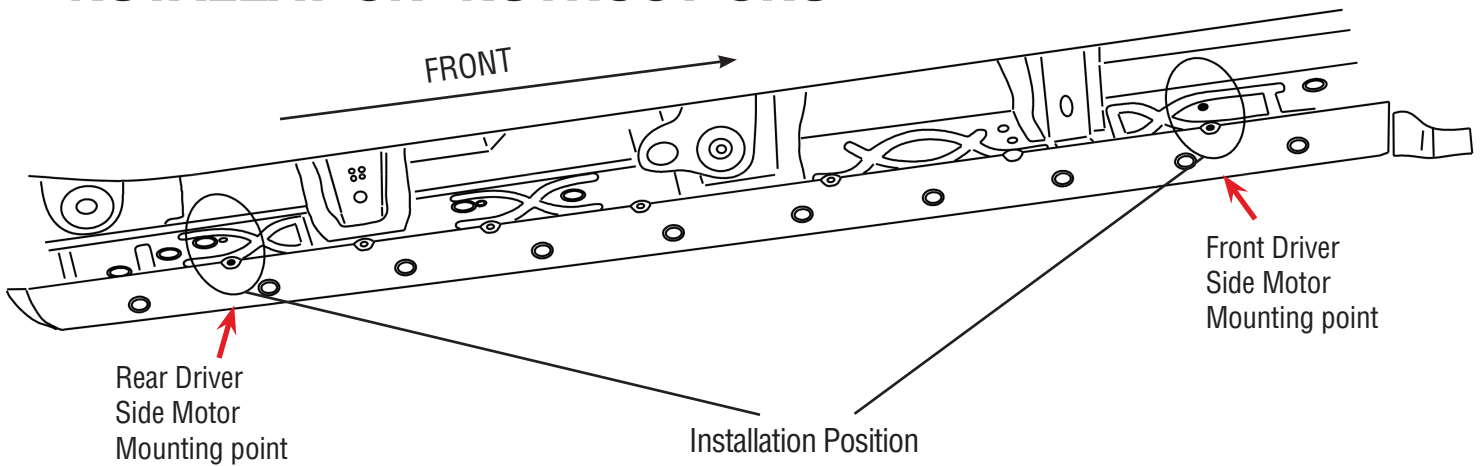

Step 1: Disconnect the battery. Begin with the negative battery terminal, followed by the positive terminal.

Step 2: Inspect the front Driver side and rear Driver side motor mounting points on the truck. If your truck is equipped with threaded inserts as shown, skip to Step 5.

Step 3: Holes that do not have factory threaded inserts will require the threaded nut bracket that is included in this kit. To install it, feed the bracket through the slot and let it hang from the small tab as shown.



Step 1



Step 3

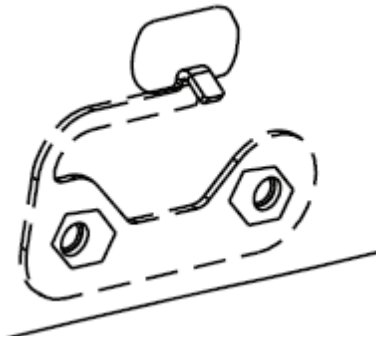

Step 4

Step 4: Install the rear Driver side motor using two M6 flange bolts to fasten the motor to the pinch seam and two M8 flange bolts to fasten the motor to the threaded nut bracket. Hold the bracket by the hang tab to avoid it falling into the rocker panel. The hardware should be hand tightened only until snug. This will allow the motor assembly to move and align easier when installing the running board.



INSTALLATION INSTRUCTIONS

Step 5: Install the front Driver side motor using two M6 flange bolts to fasten the motor to the pinch seam and two M8 flange bolts to fasten the motor to the threaded nut bracket. Hold the bracket by the hang tab to avoid it falling into the rocker panel. The hardware should be hand tightened only until snug. This will allow the motor assembly to move and align easier when installing the running board.

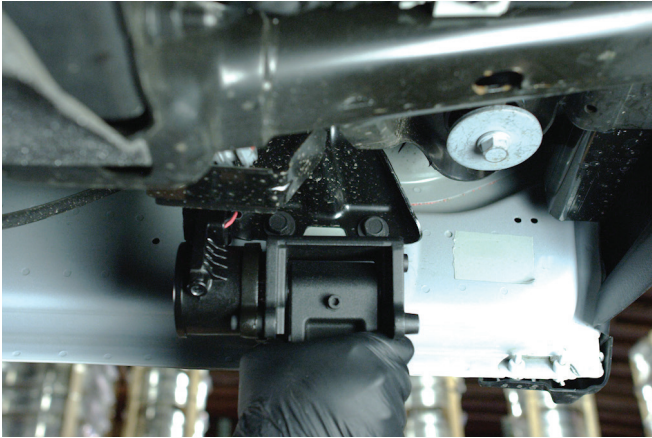

Step 5A



Step 5B

Step 6: Install the Driver Side running board.

6a. Begin by propping up the running board on the front and rear motor assembly bases.

6b. Next align the sliding T-Nut assemblies on the running board with the slots on the front and rear motor bases.

6c. Once the T-nuts are aligned, rotate the running board so that the T-nuts drop into the slots on the base of the arms.

6d. Secure the running board to the arms using the M6 x 25 socket head cap screws. Using a torque wrench, tighten to 9 ft-lbs.



Step 6A



Step 6B

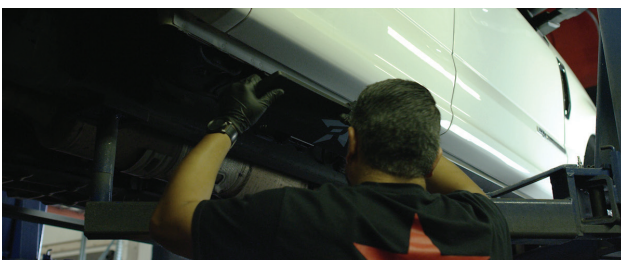

Step 6C



Step 6D

INSTALLATION INSTRUCTIONS

Step 7: Now that the running board is installed, go back and tighten the hardware on the Driver Side front and rear motor assemblies. Using a torque wrench, tighten the mounting hardware to 18 ft-lbs.

Step 8: Repeat steps 2-7 to install the motor linkage assemblies and running board on the Passenger Side.

Step 9: Locate factory step mounting hole pattern just below the middle body mount on the driver side of the truck. Peel the tape covering the large slot. Feed the threaded bracket through the slot and let it hang from the small tab as shown.

Step 10: Install the controller bracket using two M8 flange bolts. Using a torque wrench, tighten to 18 ft-lb.

Controller mounting bracket

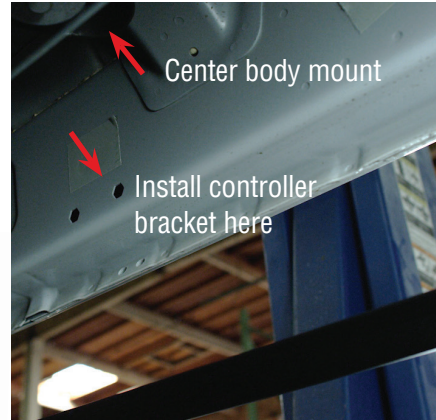

Step 9

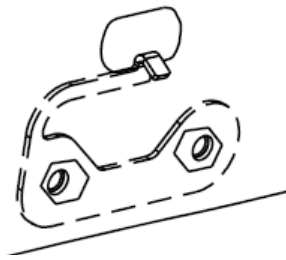

threaded insert

Step 11: Locate the electrical pigtail with the female socket connector on the driver side front and rear motors. Route the electrical harness from the controller along the frame rail of the truck. Connect the male plug connector on the wire harness into the female socket on the motor. The harness is labeled Front Left for the front Driver motor and Rear Left for the rear driver side motor.

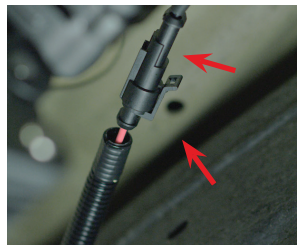

Step 11

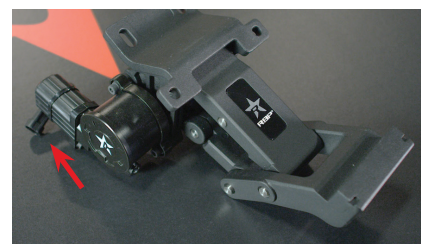

Step 12: Align the arrows on the small round connectors and plug the driver side front and driver side rear LED lights. Prepare the surface by cleaning with a 50/50 mix of isopropyl alcohol and water or equivalent. Once the surface is completely dry, peel the backing from the double-sided tape and stick the LEDs to the bottom side of the rocker panel. Stick the LED lights at the center of the front and rear driver side doors.



Step 12



Step 13: Route the motor and LED wire harness from the controller on the driver side of the vehicle to the passenger side frame rail of the vehicle. When routing the harness keep clear from any moving parts and avoid direct contact with the exhaust system.

INSTALLATION INSTRUCTIONS

Step 14: Install the controller bracket using two M8 flange bolts and on M8 Hex Nut for the bottom bolt. Using a torque wrench, tighten to 18 ft-lb.

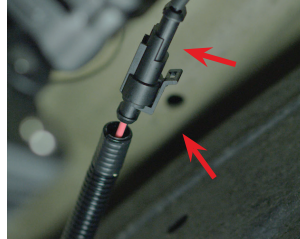

Step 14

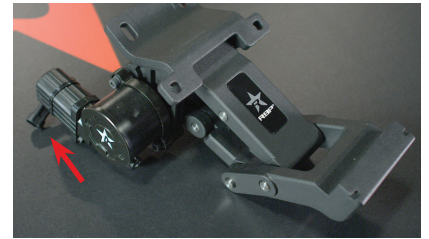

Step 15: Align the arrows on the small round connectors and plug the passenger side front and passenger side rear LED lights. Prepare the surface by cleaning with a 50/50 mix of isopropyl alcohol and water or equivalent. Once the surface is completely dry, peel the backing from the double-sided tape and stick the LEDs to the bottom side of the rocker panel. Stick the LED lights at the center of the front and rear passenger side doors.



Step 15



Step 16: On the driver side, remove the front kick panel, front door sill trim panel, b-pillar trim panel and pull the front driver carpet back. Now go under the truck and locate the plastic grommet on the driver side floorboard. Drill a 7/16" hole as shown. Make sure not to drill through the carpet. We recommend placing something between the floorboard and the carpet to keep it away from the drill bit when it breaks through.



Step 16



Step 17: Feed the door trigger signal wires (white and brown) and the disable switch wires (two black wires) into the cab. Seal around the wires using RTV silicone adhesive to prevent water intrusion.



Step 17



Step 18

INSTALLATION INSTRUCTIONS

Step 18: Route the driver side door trigger wire (brown) towards the driver side b-pillar. Route the passenger side door trigger wire (white) under the center console and over to the passenger side b-pillar. Route the black disable switch wires to the center console.

Step 19: The door trigger sensor harness will need a ground connection to the vehicle. Locate the seat belt assembly at the driver side b-pillar and install the ground wire under the top bolt of the seat belt assembly.

Step 20: Connect the snap in bullet connector to the brown wire on the passenger side.

Step 21: Apply a vertically oriented strip of masking tape on the front driver side door using the deepest part of the latch as a reference point. Make a mark 1.5" below the center line of the latch. Prepare the surface by cleaning with a 50/50 mix of isopropyl alcohol and water or equivalent. Once the surface is completely dry, peel the backing from the double-sided tape and stick the magnet to the door. Align the top of the magnet with the 1.5" mark as shown.

Step 22: Apply a vertically oriented strip of masking tape on the door jamb using the outer edge of the front driver side door striker as a reference point. Make a mark 1.5" below the center line of the striker. Lift the bulb door seal to route the sensor wire underneath it. Prepare the surface by cleaning with a 50/50 mix of isopropyl alcohol and water or equivalent. Once the surface is completely dry, peel the backing from the double-sided tape and stick the sensor to the door jamb. Align the top of the sensor with the 1.5" mark as shown.



Step 19



Step 20

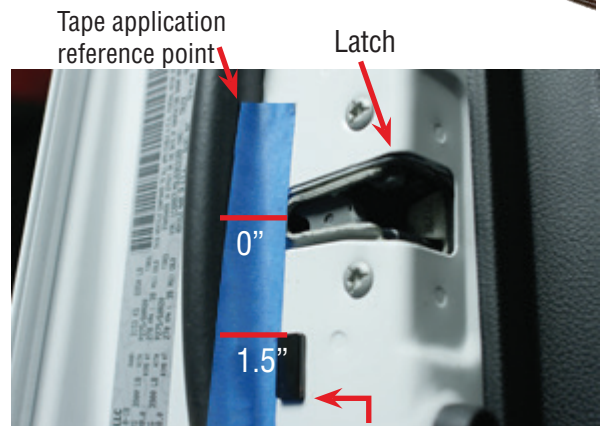

Step 21

Front door magnet



Step 22

INSTALLATION INSTRUCTIONS

Step 23: Apply a horizontally oriented strip of masking tape on the rear driver side door jamb using the door detent as a reference point. Make a mark 0.5" from the edge marked as 0". Prepare the surface by cleaning with a 50/50 mix of isopropyl alcohol and water or equivalent. Lift the bulb door seal to route the sensor wire underneath it. Once the surface is completely dry, peel the backing from the double-sided tape and stick the rear door sensor to the door jamb. Align the top left corner of the sensor with the 0.5" mark as shown.

Step 24: Extend the masking tape used for the sensor over to the inside door trim panel as shown. Prepare the surface by cleaning with a 50/50 mix of isopropyl alcohol and water or equivalent. Once the surface is completely dry, peel the backing from the double-sided tape and stick the magnet to the door. Align the top edge of the magnet with the tape and the right side of the magnet with bulb seal as shown.

Step 25: Repeat steps 19-24 to install the passenger side door trigger sensors and magnets. The passenger side door trigger harness is connected to the white wire that was routed under the carpet to the driver side b-pillar in step 18.

Step 26: Remove the left center console trim panel. Prepare the surface by cleaning with a 50/50 mix of isopropyl alcohol and water or equivalent. Once the surface is completely dry, peel the backing from the double-sided tape and stick the disable switch on the lower dash panel. Plug the disable switch connector into the black wire harness that was routed under the carpet to the center console in step 18.

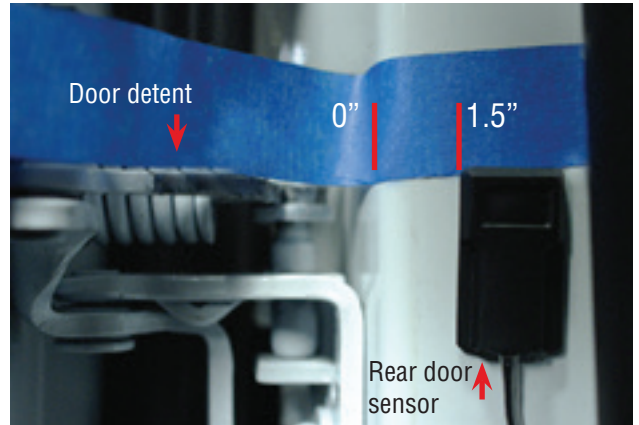
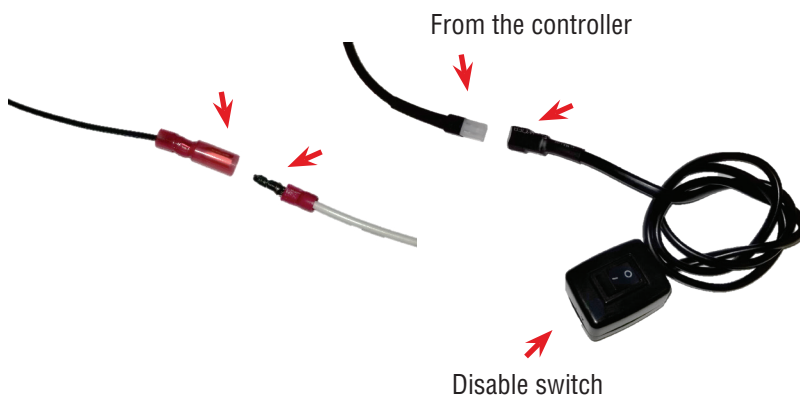

Step 23

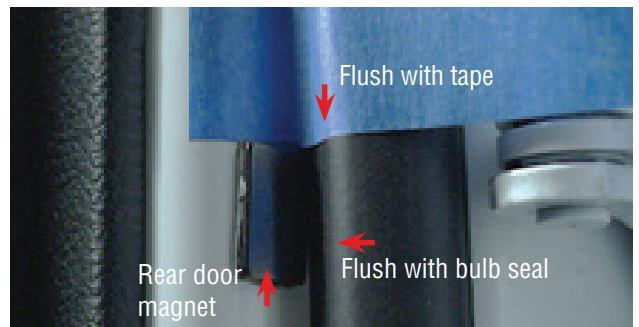

Step 24

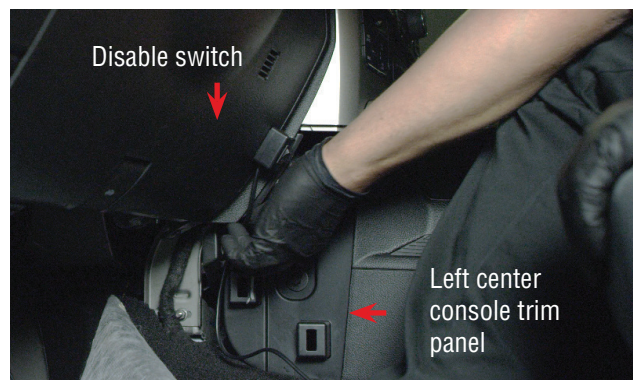

Step 25

INSTALLATION INSTRUCTIONS

Step 27: Install the left center console trim panel and tuck the disable switch harness behind the lower dash panel

Step 28: Remove the 20 Amp fuses from the main positive and negative 12V power leads on the main harness. Route the power wires over the wheel well and into the engine compartment. Connect the ring terminals to the battery positive and negative posts.

Step 29: Install the 20 Amp fuses back on the main negative and positive 12V power leads of the main power harness.

Step 30: Connect the battery. Begin with the positive terminal, followed by the negative terminal.

Step 31: Open and close all four doors to test the operation of your new Stealth Power Running boards. Please note that there is a 4 second delay for the running boards to retract after the doors are closed.

Step 32: Open the driver side door and keep the door open. Flip the disable switch to the “O” or Off position. This will signal the running boards to retract to the stowed position and it will disable any further operation until the switch is flipped to the “I” or On position.

Thank you for choosing RBP! We hope you enjoy your new Stealth Power Running Boards. We would love to hear about your experience and see your vehicle decked out with our products. To share simply tag us using #Rollingbigpower, #RBP or #RBPStealthPower or DM us on Facebook and Instagram and visit us on YouTube!

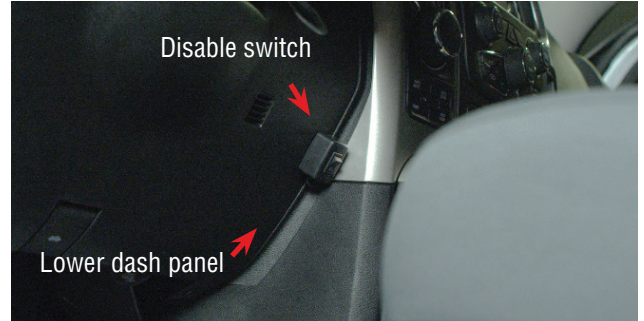

Step 27

Step 28

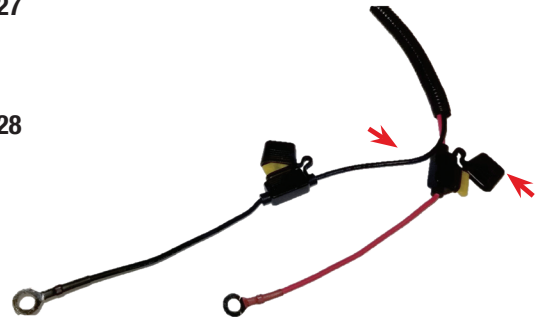

Step 30



FOLLOW US



OfficialRBP



@rollingbigpower



RollingBigPowerTV



RBP STEALTH POWER WARRANTY

Rolling Big Power believes in true customer satisfaction. We strive to provide you, our customer, with a delightful experience with our products. In the event that your experience is not delightful - please contact us and allow one of our professional customer service agents take care of you. Our primary goal is for you to become a customer for life - we're willing to earn it.

Rolling Big Power warrants that any RBP product purchased from an RBP Authorized Resellers will be free from any defects in manufacturing, materials and workmanship for five years from original date of purchase, for the original purchaser for the product installed on the purchaser's original vehicle. Please validate your warranty by REGISTERING YOUR RBP PRODUCT.

NOTE: If you purchased an RBP product from an unauthorized reseller, the unauthorized reseller your warranty may or may not be honored. It is strongly recommended that you purchase RBP products from an RBP Authorized Resellers. To view dealers currently authorized to sell Rolling Big Power products, visit our website to see a complete list.

During the 5-year warranty period, RBP provides free replacement for any manufacturer's defects. RBP reserves the right to replace any individual component of the system, or the entire system at its sole discretion. RBP provides a limited lifetime warranty against rust on the running board assemblies for the original purchaser. Proof of purchase is required when submitting a request for warranty replacement. Within the limit of law, the interpretation of warranty policy solely belongs to RBP.

RBP STEALTH POWER WARRANTY

Exclusions to the RBP Stealth Power Warranty:

- Any product improperly installed, altered, lack of or improper maintenance or improper use of our products.
- No proof of purchase or RBP warranty registration as noted above
- Purchased from an unauthorized reseller
- Failure due to misuse, abuse, neglect or impact/collision
- Any cosmetic scratches or discoloration or any other cosmetic condition that does not affect mechanical operations
- Failure caused by force majeure
- Improper maintenance or care
- Any and all costs of removal, installation, freight, incidental or consequential damages are excluded from this warranty.



FOLLOW US



WWW.ROLLINGBIGPOWER.COM

1-877-519-9090

STRAIGHT DOIN' IT®