

COVENTRY

BRASS WORKS LIMITED

Exposed 3/4" Thermostatic Valve Installation Instructions



LEAVE FOR HOME OWNER

Care Instructions:

The Coventry Brassworks Product you have just purchased is designed to provide you with long lasting beauty and dependability. To ensure your product's longevity, please follow the following care instructions.

When installing, we recommend you lay all parts on a soft cloth or towel to avoid scratching or damaging the product. To care for your fitting, wipe with a clean, soft, damp cloth and blot dry as often as possible. Never use abrasive cleansers, sponges, or acidic cleaning products as these may damage the finish and may VOID THE WARRANTY.

Welcome to the World of Thermostatic Systems Both Exposed and Concealed Valves

Please read ALL instructions, cautions, and care recommendations before beginning installation.

Coventry Brassworks products comply with Section 9 of NSF 61 criteria concerning lead content.

! CAUTIONS !

1. **APPLY NO HEAT/NO TORCH TO THE VALVE ASSEMBLY.**
2. Take special care to protect all components during the construction and installation.
3. Open all boxes carefully. The products are heavy and damage can occur after you open the contents.
4. We suggest all products be set on a soft work surface like an old blanket for review before installation. Cement floors are too hard.
5. Always turn off water at the source before beginning installation.
6. Go slowly - A cautious installation creates a beautiful finished result.
- Caution** 7. Use no pliers, vice grips or channel locks on this finished trim - you will scratch or mar the surface.
- Caution** 8. Use a crescent wrench on all nuts - be deliberate and patient - no damage will happen.
9. If you have the factory installation tool kit, follow the instructions enclosed.
10. Concealed thermostatic systems are the norm in the USA today. Valves are usually installed inside the frame construction and there is no danger from exposed pipes.
11. All of the Coventry Thermostatic Systems are state of the art and meet or exceed all codes for approved products in the USA and Canada.
12. All systems are fail safe and will not allow hot water to exceed 120 degrees Fahrenheit during any showering or bathing experience if properly installed.
13. Each individual bather can adjust the temperature at will while using the shower. Our thermostatic systems have separate temperature controls from the exit controls.
14. Exposed hot water pipes are potentially dangerous to the unsuspecting person. We are used to concealed plumbing pipes inside the walls of a typical home. These exposed bathing/showering systems bring a new look to the USA from our English neighbors across the ocean.
15. Be advised that exposed thermostatic systems have a **HOT** water line that can be too hot to touch! **Beware of burns!**

16. Exposed piping means you can touch the cold and hot water lines.
17. Exposed piping means you can see if anything is wrong with your plumbing.
18. Exposed piping means you can service your system easily.
19. Exposed piping means you don't have to remove your walls if a problem occurs.
20. We have labeled the hot side as a preliminary caution for the homeowner. Please leave the attached label in place for the homeowner to remove when the installation is complete.
21. **1/2" copper water lines are required for the hot and cold inlets.**
22. Remember the exposed piping is **not a grab bar** and we do not imply in any way that our installation procedures are for any other purpose than to support the exposed pipes on the prepared surfaces of your walls.
23. You must provide wood backing inside the walls to mount the various units correctly (see the attached installation print #2).
24. Be sure the supplied screws will be long enough to reach the interior wood blocking or that the screws supplied with the alligator clips are going to fit in your tile or stone walls (see diagram of suggested framing).
25. The system comes with both metal and teflon ferrules. The 2 supplied 1/2" metal ferrules are for the 1/2" copper inlets only. The teflon ferrules are for the risers on the exposed pipes only.
26. All systems have been water tested at the factory to 90 lbs of static and dynamic water pressure. Thus you may find residual water inside the thermostatic valve from this testing.
27. The thermostatic valve has been factory calibrated to deliver a maximum Fahrenheit temperature of 110 to confirm proper operation. In the absence of a thermometer, the maximum water temperature should feel slightly uncomfortable to the hand.
NOTE: It is important that the valve be properly calibrated to preserve its anti-scald feature. For recalibration procedures, **(See Page 7)**.
28. Prior to installing the thermostatic body, **flush all water lines** to free up debris. The lines should be flushed long enough to remove any sediment that may come from any new installations including a water heater. It is recommended you flush lines for at least 15 minutes before connecting the new fitting, let water run from the HOT and COLD copper connecting pipe in the shower wall.
29. **Failure to flush thoroughly may damage internal parts!** An in-line water filter is recommended to remove harmful sediments.

30. Plumber's putty is not recommended. Use of caustic substances or acidic curing products for installation purposes may harm the finish or cause the product to not function properly. Please read the cautions printed on any product purchased for use during installation. It is recommended you use teflon tape approved for water application.
31. Inlet check valves are provided with the system. If factory provided check valves are removed, a qualified plumbing contractor **MUST** install check valves up stream of the valve.
32. Water pressure comes from your local water supplier and can be measured at the source. Pressure and water velocity are not functions of the valve.
33. Do not attempt installation of product if you do not understand these instructions. **Qualified plumbers should be used for all installation procedures.**
34. Call the factory if you have any questions.

Water Supply

Thermostatic valves can be supplied from any hot water production system, even by instantaneous domestic production, as far as the generator is capable of supplying very small quantities of hot water (about 0.8 gal/min).

- Maximum working pressure	145 PSI
- Minimum working pressure	14 PSI
- Recommended working pressure	29 to 58 PSI
- Maximum test pressure	224 PSI
- Maximum hot water temperature	185°F

Shower Heads:

All showerheads and hand showers comply with the approved water flow rate as required by US plumbing codes. We have installed flow restrictors in the heads.

These flow restrictors can clog from lime scale buildup, silt, sand, or debris in the water line caused from or during the construction process. If you wish to clean or service the restrictor, simply use a Phillips screwdriver and back out the plastic part - clean and reinstall.

Always keep your showerheads level and perpendicular to your floor. If any head is tilted you may not receive a satisfactory shower.

The showerheads are intentionally designed as Rain Heads. The water exits the 8" and 12" size heads like wonderful soft rain. Increased velocity does not come from the shower valve but from several other factors.

The velocity of the water is dependant on your existing street water pressure, the size of the pipes, the water meter and the design of your pipe system.

Note: This fitting has been factory assembled, tested and is ready for installation. See the tag attached to the valve to verify factory readiness.

Recommended Instructions:

Read all instructions completely before proceeding!

The Coventry Thermostatic Valve is a controlled shower mixing valve. Temperature is thermostatically controlled by a wax cartridge thermostat that maintains a constant temperature while automatically adjusting and compensating for changes in HOT and COLD inlet pressures. Should the COLD supply fail, the valve will immediately shut down to avoid any risk of scalding. Keep in mind that the distance the shower head or other exit is from the valve will determine how fast you feel the instantaneous correction in temperature. The water flow is controlled by a simple quarter turn ceramic lever. The Coventry Thermostatic Valve is suitable, without modification, for all types of installations. This includes pumped gravity systems, main pressure water systems and combination boilers.

MEETS AND EXCEEDS I.A.P.M.O. ASSE 1016 STANDARDS AND UNIFORM PLUMBING CODES

PRODUCT CARE:

The Coventry Thermostatic Valve is incredibly easy to maintain. The temperature and flow are controlled by one piece cartridges which are easily removed for cleaning and replacement. To remove the thermostatic cartridge use a crescent wrench. See Calibration Instructions to demonstrate how to properly remove the handle. To ensure full water flow, periodically clean the cartridge screens of any debris using a small brush. Rinse thoroughly before returning to the fixture. Thread cartridge into place and reassemble handle pieces as shown on calibration instructions. Soaking the cartridge in a 50/50 solution of clear household vinegar and water will remove lime scale. Regular cleaning each year will extend the life of the cartridge. **Never use a screwdriver on a thermostatic cartridge and NEVER take a thermostatic cartridge apart as you will damage the precise instrument.** Call your dealer or the factory for answers to your questions. **Remember, after removing the cartridge, you must recalibrate.**

INSTALLATION:

The Coventry Thermostatic Valve must be installed with the outlet pointing upwards, so that the HOT water enters on the left, and the COLD water on the right, as shown in Figure A. **THE VALVE WILL NOT FUNCTION IF REVERSED!** The inlet elbows are fitted with compression nuts. Be sure to **flush thoroughly all new plumbing for up to 15 minutes** before connecting the valve to clear out all debris in your water lines. The valve should be screwed to the wall with the stainless steel screws provided.

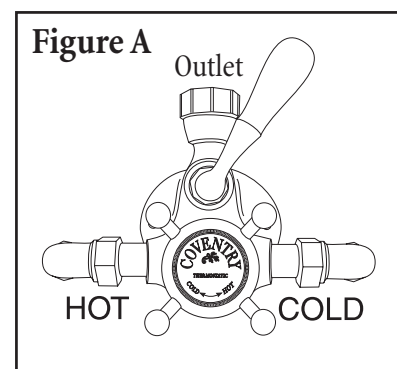

INSTALLATION:

Next, cut the 1/2" copper pipes so that they extend approximately 7/8" from the finished wall.

(See Figure C below) Slip the wall flange over the pipe. Next, slide on the compression nut so that the bottom fits into the wall flange. Slide the ferrule down the pipe. It will pinch into the copper securing the elbow when you tighten the nut onto the elbow. Next, secure the nuts to the elbows by tightening the set screws with the allen key.

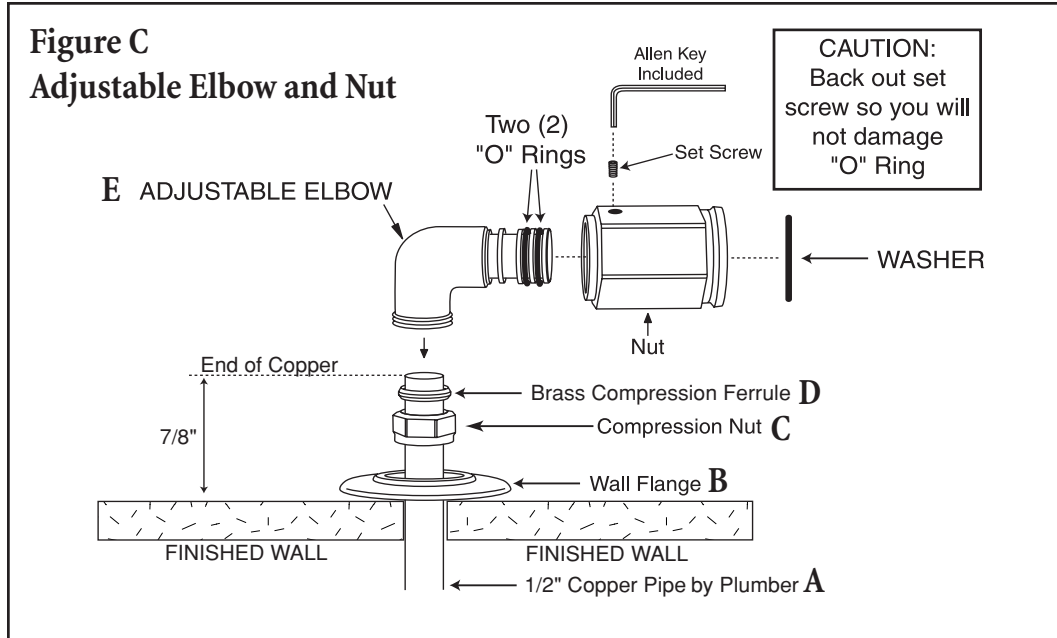

“ Please Note ”: The entire valve body must be installed over the copper pipes
- **at one time** - you may loosen the set screw on the Large Hex Nut to allow flexibility in the installation, but do not separate the components.
See Figure D below.

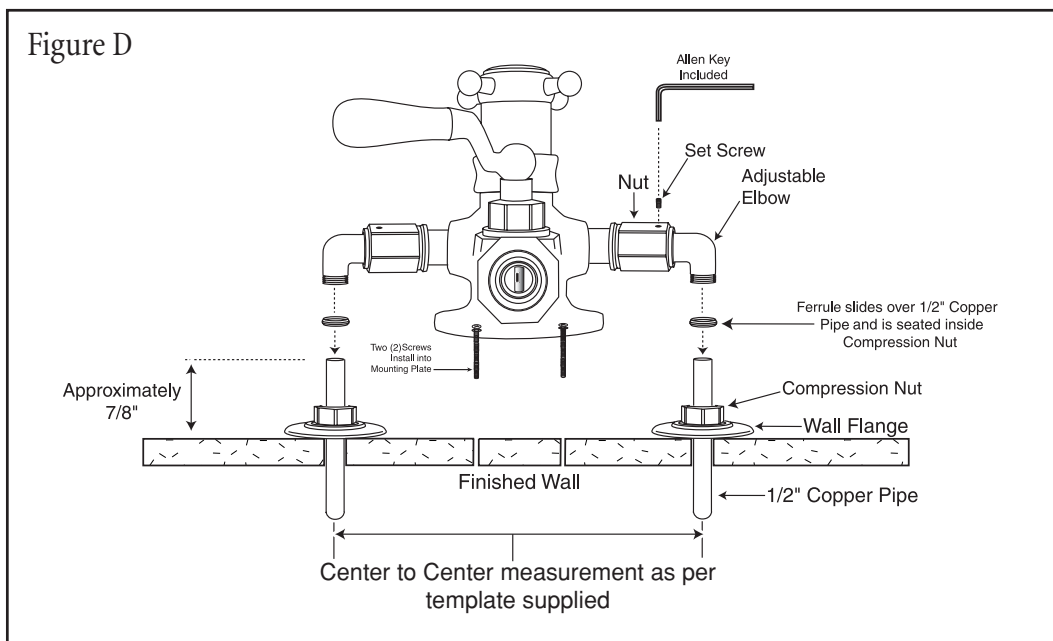

CALIBRATION INSTRUCTIONS:

FOR TEMPERATURE SETTING AND ADJUSTMENTS

Calibration is the simple process by which you control the temperature range of mixed water. The Coventry Thermostatic Valve has been factory tested and calibrated to preserve its anti-scald feature when installed in your home. If you desire a hotter or colder temperature range, you can recalibrate the valve after installation, when both HOT and COLD lines are 100% operational, and all installation debris have been flushed from the water lines and the valve body. The factory has preset the valve at 110°F maximum. You may feel a 2 or 3 degree variance but turning the temperature handle will be the simple way to change the temperature.

TO CALIBRATE TEMPERATURE SETTING: (SEE FULL TEXT ATTACHED)

Begin by unscrewing the Coventry button in the center of the temperature control knob with your thumb and forefinger, as shown in Figure E. Then use a large screwdriver to loosen and remove the large screw in the center which secures the handle onto the thermostatic cartridge. (See Figure E-3)

When the screw is removed, turn the cartridge slightly counterclockwise to increase the maximum temperature, or slightly clockwise to decrease the maximum temperature. Push the handle back on and check water temperature. Remount the handle, tighten the large screw into the center of the handle and then tighten the Coventry button. ***Under no circumstances is the thermostatic cartridge to be dismantled. Doing so will VOID THE WARRANTY and possibly make the cartridge inoperable. (SEE FULL TEXT)***

Figure E

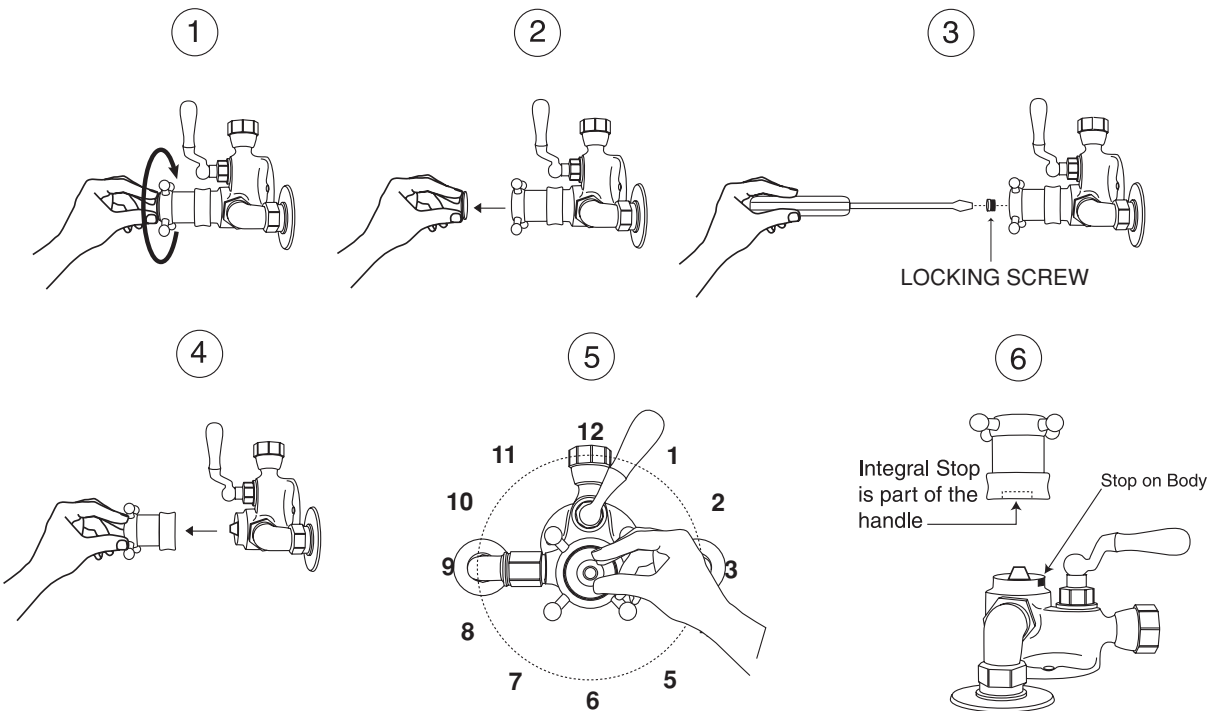

SEE FULL TEXT PAGE 8

Calibration instructions for the Exposed 3/4" Thermostatic Valve Only

This is the full text of the installation and application procedures required to recalibrate this particular cartridge as it comes from the factory.

The Coventry valve has been factory calibrated to allow a maximum water temperature of 110° F to be set. This is an important safety feature. In some circumstances, and after the thermostatic cartridge has been removed for servicing, it will be necessary to recalibrate the valve. It is important that this calibration is carried out properly to preserve the anti-scald function of the valve.

Calibration is nothing more than the proper mixture of hot and cold water that is entering the valve. The proper mixture is nothing more than the end bather's perception of a proper shower. When we calibrate we simply adjust the incoming hot and cold water to a normal balance so that the bather has a comfortable and secure shower.

1. Reviewing the figure "E" print, the diagram shows how to remove the Coventry white ceramic button. This button is installed simply using your finger and thumb to remove or install the button.
2. If you next go to **(Print #1 PAGE 8)** you will see the exploded view of the exposed thermostatic valve. We would ask you to note several things; (1) at the very top of the page is the locking screw. As it shows, you will need a large screwdriver. Do not attempt this with a small screwdriver as brass is soft and you will strip the head out of the screw, therefore making it difficult to resecure the handle body in place.
3. Now, look at the handle body. If you remove it you will notice that built inside as an integral part of the body is a stop. This stop is important because depending on how you line it up on the stop, shown down on the body, you may or may not be able to adjust the handle for its full range of motion. The exploded view is important and it's simple. It gives you a visual point of view on how all the parts go together and come apart.
4. After you have removed the button and have used a large screwdriver to remove the center screw holding the handle onto the assembly, the next step is to actually run the water so you can set the range of temperature for your convenience. When the water is running, turn the center of the thermostatic cartridge as shown in print #1. **For colder water rotate the cartridge clockwise. For warmer water rotate the cartridge counterclockwise only slightly in either direction.**
5. After you have balanced the hot side and cold side while the water is running, you will determine whether this is the proper water temperature for your shower. We recommend that it be only slightly hotter than what you would shower at, so you can turn the handle after it is reinstalled to a cooler or hotter temperature.
6. Reinstall the handle so that the integral stop inside the sleeve lines up to the left side of the stop on the body. Rotate the handle counterclockwise until it hits the stop point.
7. In this position, reinstall the center screw (with the large screwdriver), tighten securely, and check this temperature setting. When complete you will have set the maximum temperature for this valve.
8. Now rotate this temperature handle with the water running 2 or 3 times. You will see how simple it is to increase or decrease your bathing water temperature.
9. Reinstall the center cap using your thumb and forefinger and you are ready to take a safe, secure and comfortable shower.

EXPOSED 3/4" THERMOSTATIC VALVE

EXPLODED VIEW

PRINT 1

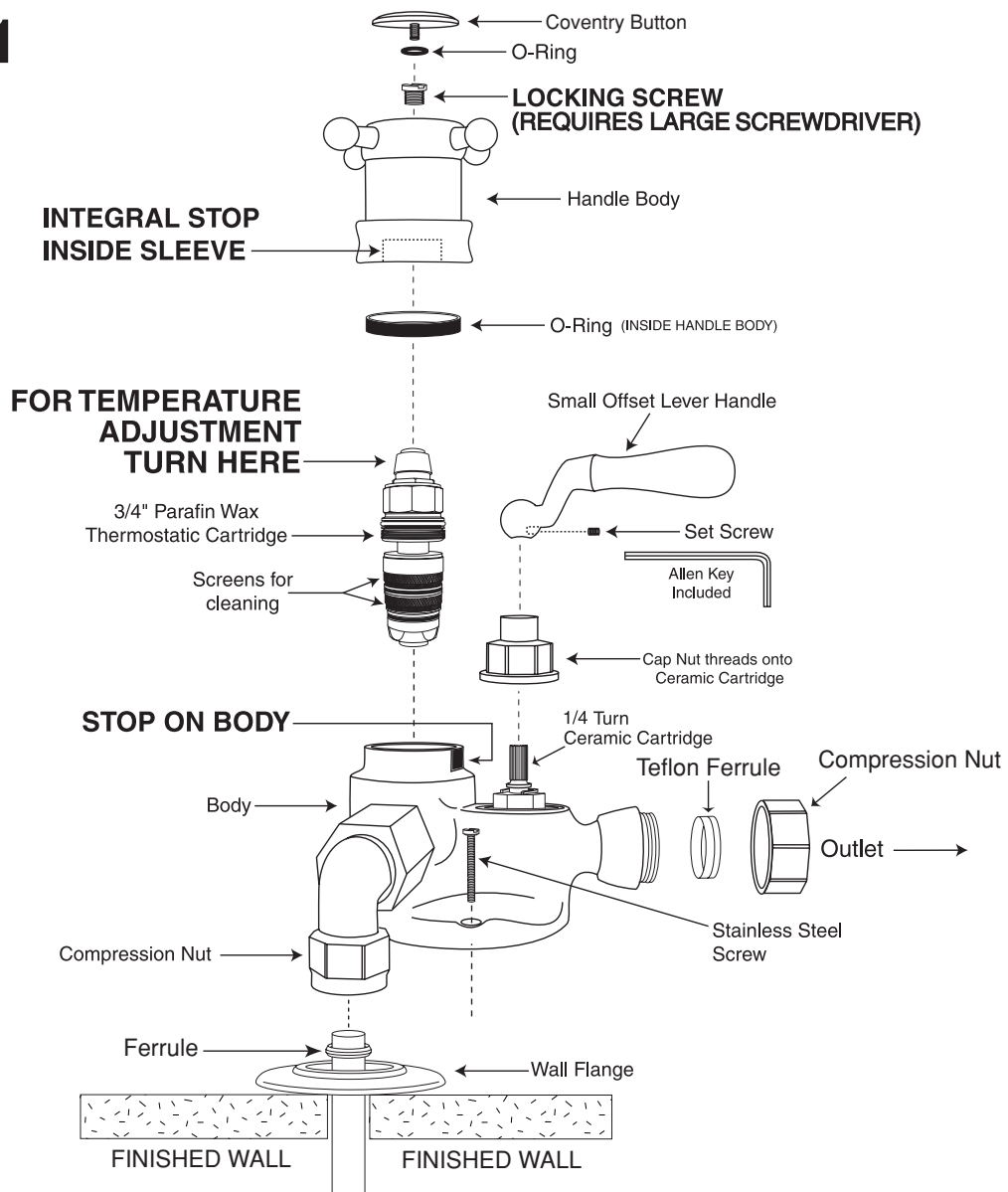

TROUBLE SHOOTING:

The Coventry Thermostatic valve is remarkably dependable and reliable, providing you with a lifetime of service and beauty. The following three problems, and the simple solutions to each, have accounted for nearly all difficulties with this valve.

1.) After Installation the shower only runs HOT or COLD water, and will not mix.
SOLUTION: *You have the HOT and COLD plumbed the wrong way around. The correct plumbing is HOT on the LEFT and COLD on the right.*

2.) The shower will not run hot enough when first installed.

SOLUTION: *First verify that the water heater is set at 135°F or more. If such is the case, then maximum temperature needs to be set at a higher temperature. To readjust the temperature range, follow **CALIBRATION INSTRUCTIONS.***

3.) Cold water tracking through the valve into the hot system on combination boiler systems.

SOLUTION: *This is prevented in the Coventry Thermostatic Valve by built-in check valves in the inlets. Check and clean the built-in valves. There may be debris in the plastic check valve.*

Installation begins by selecting the centerline of 2" x 4" backing studs at the factory suggested location of 42" to 48" as shown in (**Print 2**). The mounting plate is secured through the use of four metal screws. Note: The wall surface must be level on all sides of the centerline, otherwise the thermostatic system will not look level and straight when installed.

RECOMMENDED TYPICAL WALL FRAMING CONCEPT

PRINT 2

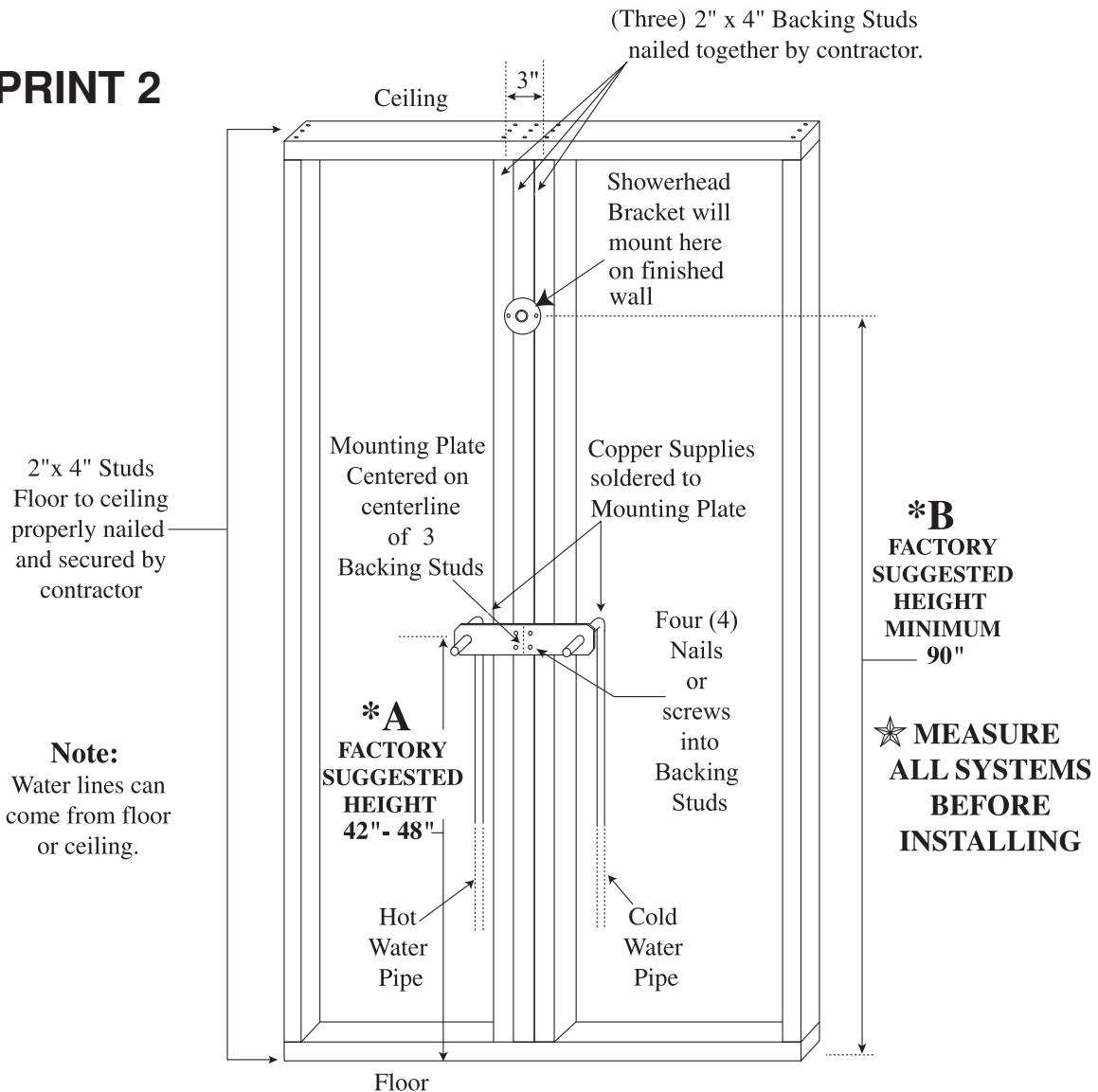

Note:
Water lines can
come from floor
or ceiling.

*** Note: These are factory suggestions only - The 90" Height at *B will allow a 6'5" tall person to walk underneath without bending.**

Typical Finished Installation of Exposed Thermostatic Wall Units

PRINT 3

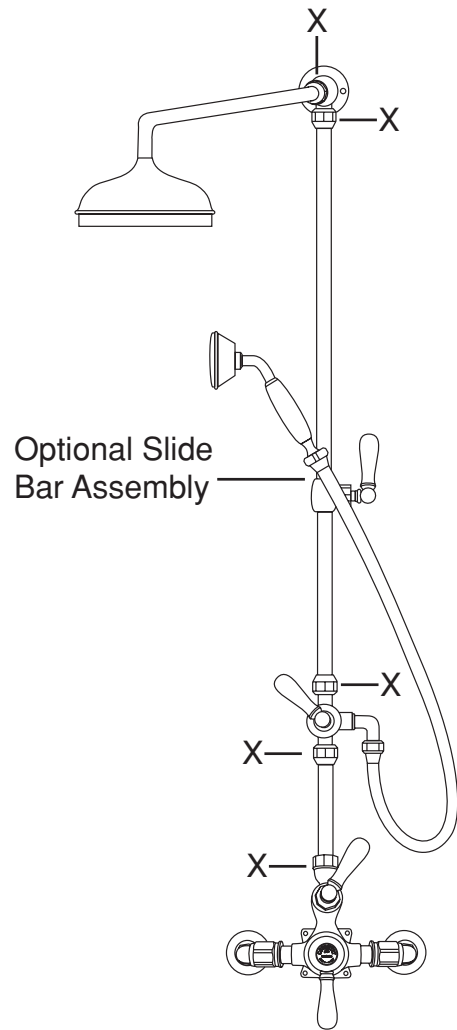

1/2" THERMOSTATIC VALVE

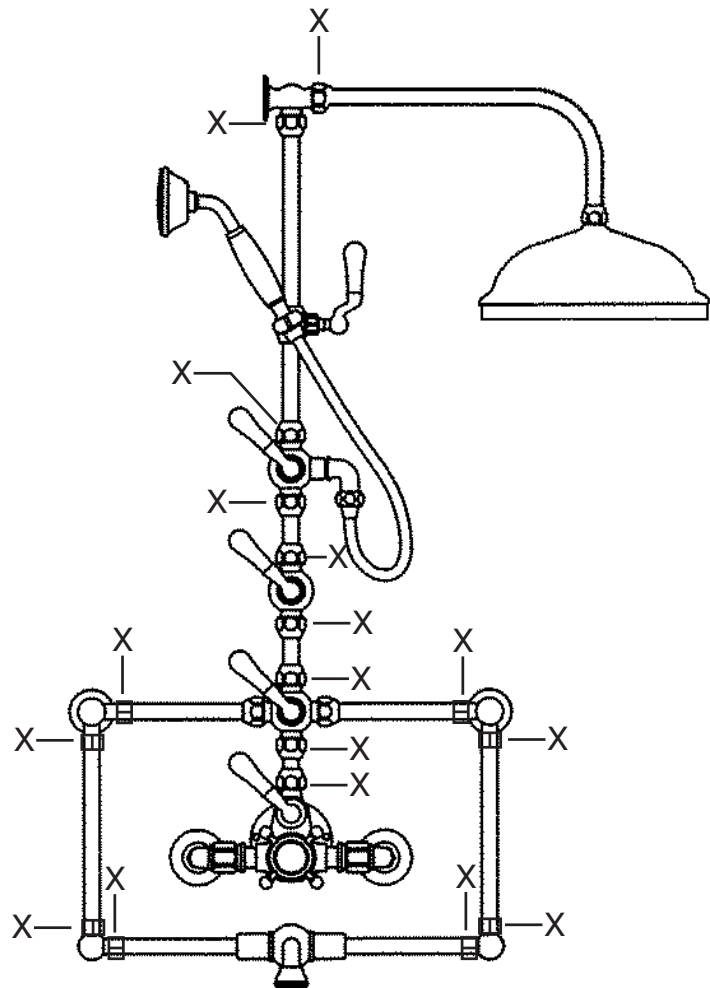

3/4" THERMOSTATIC VALVE

- Note: 1. All Supplied Piping may be cut shorter provided there are no threads on the end you wish to cut!
2. All "X" designated points are Teflon Compression Fittings and the pipe can be cut by the installer to fit particular bath requirements.

**SUGGESTED INSTALLATION OF MOUNTING FOR 3/4" EXPOSED
THERMOSTATIC SYSTEM.**

THIS PLATE IS INSTALLED ON THE WOOD BACKING DESIGNATED ON PRINT 2.

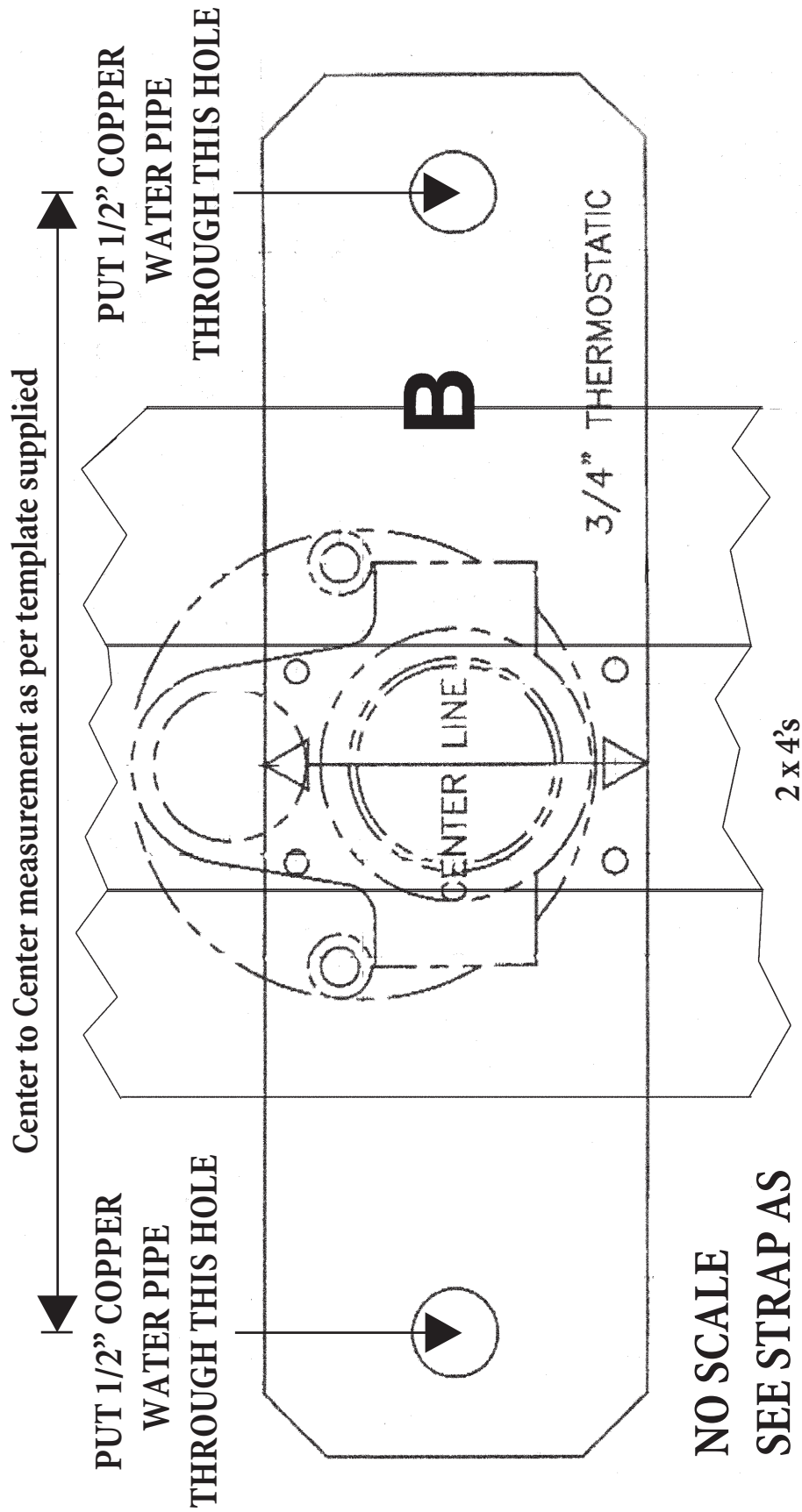

**NO SCALE
SEE STRAP AS
SUPPLIED IN BOX**

Coventry Brassworks Ltd.

Coventry Exposed 3/4" Thermostatic Valve Assembly

PRINT 4

