

NEWTON FIRE TABLE - CHAIN SUPPORT

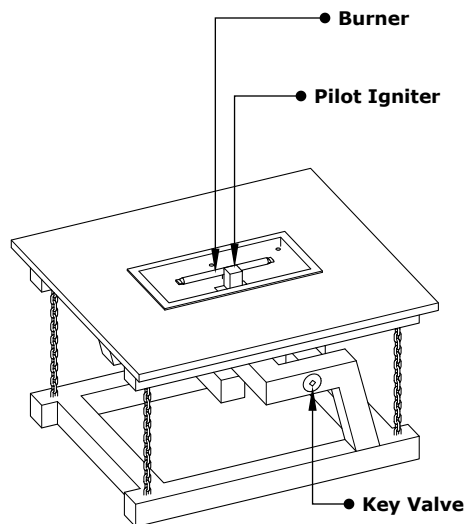

ISOMETRIC VIEW

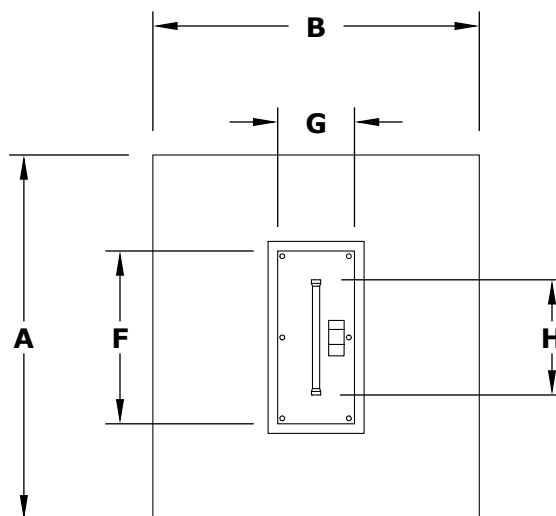

TOP VIEW

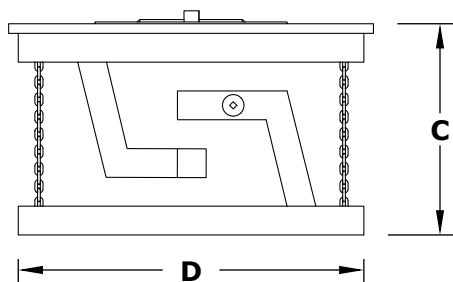

RIGHT SIDE VIEW

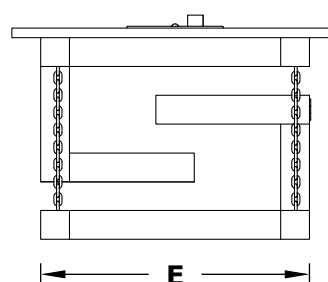

FRONT SIDE VIEW

PART NUMBER	A	B	C	D	E	F	G	H	BTU
OPT-NWT238	38"	34"	22"	36"	28"	18"	8"	12"	25,000
OPT-NWT252	52"	34"	22"	48"	28"	24"	8"	18"	35,000
OPT-NWT266	66"	34"	22"	60"	28"	36"	8"	24"	50,000

Fire Pit Material: Steel
Pan Material: 304 Stainless Steel
Burner Material: 304 Stainless Steel

Standard 2" Flange on all pans
Standard 2" Depth on all pans

110V ELECTRONIC IGNITION
ANSI Z21.97-(2017) / CSA 2.41-(2017)



Match Lit Unit Includes: Pan, Burner, Gas Orifice, Gas Hoses, Key Valve, Key,
110v Ignition Unit Includes: Pan, Burner, Gas Orifice, Gas Hoses, Key Valve, Key, Plug & Play Electronic Valve, Pilot Igniter.