

LED MANILA FIRE PIT

POWDER COAT
OPT-MNLPC(XX)

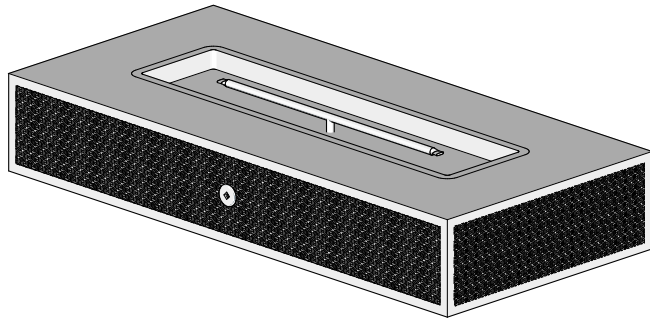

ISOMETRIC VIEW

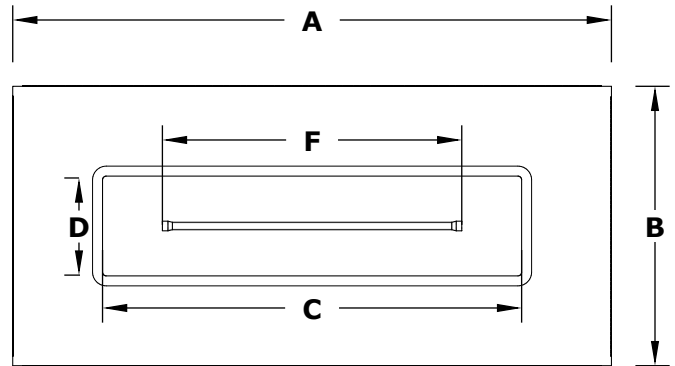

TOP VIEW

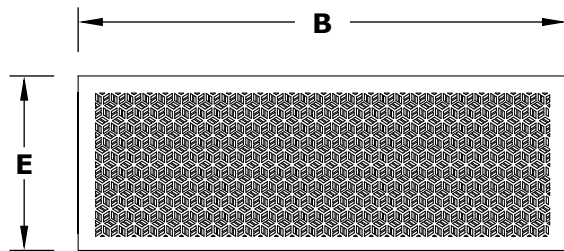

RIGHT SIDE VIEW

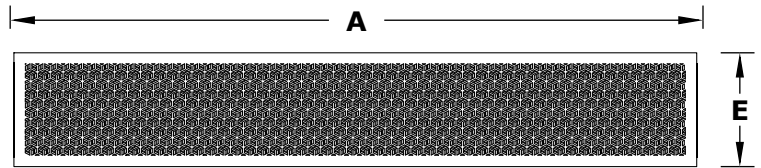

RIGHT SIDE VIEW

SKU	A	B	C	D	E	F	BTU
OPT-MNLPC48	48"	28"	30"	10"	10"	24"	65,000
OPT-MNLPC60	60"	28"	42"	10"	10"	30"	65,000
OPT-MNLPC72	72"	28"	54"	10"	10"	42"	65,000
OPT-MNLPC84	84"	28"	66"	10"	10"	54"	65,000
OPT-MNLPC96	96"	28"	78"	10"	10"	60"	65,000

Fire Pit Material: Powder Coat
Pan Material: 304 Stainless Steel
Burner Material: 304 Stainless Steel
Standard 2" Depth on all pans
110V ELECTRONIC IGNITION
ANSI Z21.97-(2017) / CSA 2.41-(2017)



Match Lit Unit Includes: Pan, Burner, Gas Orifice, Gas Hoses, Key Valve, Key,
110v Ignition Unit Includes: Pan, Burner, Gas Orifice, Gas Hoses, Key Valve, Key, Plug & Play Electronic Valve, Pilot Igniter.

--	--