

Temperature Sensor NTC M5-HS

www.bosch-motorsport.com



- ▶ Wide measurement range: -55 to 300°C
- ▶ Very short response time
- ▶ Strong protection against ambient temperature
- ▶ Compact and robust design

This sensor is designed to measure temperatures up to 300°C of oil, water, fuel or air. This signal is used as a control value for engine control units or as a measurement value which is logged in a data acquisition system.

The NTC-sensing element has a negative temperature coefficient. This means, that with increasing temperature the conductivity rises and the resistance decreases. To improve a good protection against the ambient temperature, the housing is made of stainless steel and partly filled with an isolation-paste.

The main benefit of the sensor is a very compact design and its very short response time.

Application

Application	-55 to 300°C
Storage temperature range	0 to 100°C
Bio fuel compatibility	-

Technical Specifications

Mechanical Data

Male thread	M5
Wrench size	8 mm

Installation torque	8 Nm
Weight w/o wire	6 g
Sealing	O-Ring 4 x 1 mm

Electrical Data

Characteristic	NTC
Nominal resistance at 25°C	10 kOhm ± 1 %

Characteristic

Accuracy at 25°C (homogeneous cond.)	± 0.3°C
Accuracy at 100°C (homogeneous cond.)	± 1.3°C
Response time tau 63 in still water	< 4 s

Characteristic Application

T [°C]	R [Ohm]
-55	519,910
-35	158,090
-20	71,668

-10	44,087
0	27,936
10	18,187
20	12,136
25	10,000
30	8,284
40	5,774
50	4,103
60	2,967
70	2,182
80	1,629
90	1,234
100	946.6
120	578.1
140	368.8
160	244.4
180	167.6
200	118.5
220	86.08
240	64.08
260	48.76
280	37.86
300	29.94

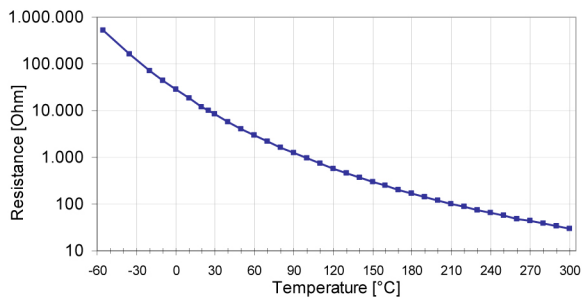

Connectors and Wires

Connector	ASL 6-06-05PN-HE
Mating connector	F 02U 000 231-01
ASL 0-06-05SN-HE	
Pin 1	-
Pin 2	Sig-
Pin 3	Sig+
Pin 4	-
Pin 5	-

Various motorsport and automotive connectors are available on request.

Wire size	AWG 24
Wire length L	15 to 50 cm

Please specify the required wire length with your order.

Installation Notes

The NTC M5-HS can be connected directly to most control units using a pull-up resistance (typically 1 or 3 kOhm) .

Any mounting orientation is possible.

Please find further application hints in the offer drawing at our homepage.

Free download of the sensor configuration file (*.sdf) for the Bosch Data Logging System at our homepage.

Safety Note

The sensor is not intended to be used for safety related applications without appropriate measures for signal validation in the application system.

Ordering Information

Temperature Sensor NTC M5-HS

Order number **F 02U V00 510-01**

Dimensions

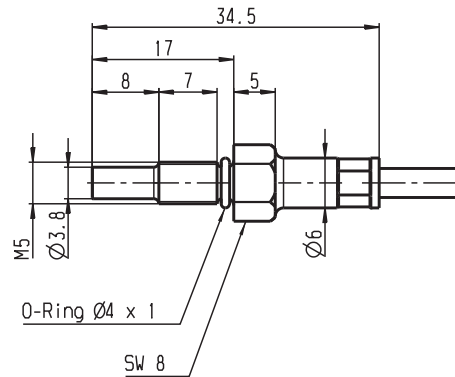

Represented by:

Europe:
 Bosch Engineering GmbH
 Motorsport
 Robert-Bosch-Allee 1
 74232 Abstatt
 Germany
 Tel.: +49 7062 911 9101
 Fax: +49 7062 911 79104
 motorsport@bosch.com
 www.bosch-motorsport.de

North America:
 Bosch Engineering North America
 Motorsport
 38000 Hills Tech Drive
 Farmington Hills, MI 48331-3417
 United States of America
 Tel.: +1 248 876 2977
 Fax: +1 248 876 7373
 motorsport@bosch.com
 www.bosch-motorsport.com

Latin America:
 Robert Bosch Ltda
 Motorsport
 Av Juscelino Kubitscheck de
 Oliveira 11800
 Zip code 81460-900
 Curitiba - Parana
 Brasilia
 Tel.: +55 41 3341 2057
 Fax: +55 41 3341 2779

Asia-Pacific:
 Bosch Engineering Japan K.K.
 Motorsport
 18F Queen's Tower C, 2-3-5 Minato Mirai
 Nishi-ku, Yokohama-shi
 Kanagawa 220-6218
 Japan
 Tel.: +81 45 650 5610
 Fax: +81 45 650 5611
 www.bosch-motorsport.jp

Australia, New Zealand and South Africa:
 Robert Bosch Pty. Ltd
 Motorsport
 1555 Centre Road
 Clayton, Victoria, 3168
 Australia
 Tel.: +61 (3) 9541 3901
 motor.sport@au.bosch.com